



SAPIENZA
UNIVERSITÀ DI ROMA

Percolation in the Miller-Abrahams random resistor network

Scuola di Dottorato Vito Volterra, Università di Roma "Sapienza"
Dottorato di Ricerca in Matematica – XXXII Ciclo

Candidate

Hlafo Alfie Mimun
ID number 1462737

Thesis Advisor

Prof. Alessandra Faggionato

30 October 2019

Thesis defended on 28 January 2020
in front of a Board of Examiners composed by:

Prof. Pietro Caputo
Prof. Francesco Caravenna
Prof. Paolo Dai Pra

Percolation in the Miller-Abrahams random resistor network

Ph.D. thesis. Sapienza – University of Rome

© 2019 Hlafo Alfie Mimun. All rights reserved

This thesis has been typeset by L^AT_EX and the Sapthesis class.

Version: January 21, 2020

Author's email: mimun@mat.uniroma1.it

*Dedicated to those
who have always had
the strength to believe
in themselves.*

Ringraziamenti

I tre anni di dottorato hanno rappresentato per me una grande opportunità di evoluzione dal punto di vista accademico ed umano. Ringrazio la mia relatrice Alessandra Faggionato per avermi seguito durante questo percorso nonostante tutte le difficoltà affrontate e per avermi fatto crescere tanto. Ringrazio la mia famiglia e gli amici per essermi sempre stati accanto. Ringrazio i vari docenti con i quali sono entrato in contatto durante questi anni e che mi hanno permesso di allargare i miei orizzonti. Ringrazio i miei colleghi dottorandi delle università di Roma “Sapienza” e “Roma 3” con i quali ho condiviso questa grandiosa esperienza in tutte le sue sfumature. Infine un ringraziamento particolare lo dedico al mio collega e amico Matteo Quattropani per essere stato un fondamentale compagno in questo viaggio.

Contents

Introduction	ix
1 Marked simple point processes	1
1.1 Counting measures and marked simple point processes	1
1.2 Stationarity and ergodicity	4
1.3 Campbell measure and Palm distribution	7
1.3.1 The stationary case	8
1.4 Poisson point process	9
2 Discrete and continuum percolation	13
2.1 Discrete percolation	13
2.1.1 The supercritical phase	15
2.1.2 The subcritical phase	16
2.1.3 FKG inequality and Russo's formula	17
2.2 Continuum percolation	18
2.2.1 The random connection model	18
2.2.2 The Boolean model	19
3 Randomized algorithms: an application to Bernoulli bond percolation	23
3.1 Randomized algorithms	23
4 Connection probabilities in Poisson random graphs with uniformly bounded edges	31
4.1 Introduction	31
4.1.1 Extension to other Poisson models	34
4.2 Phase transition in the MA model	35
4.3 Outline of the proof of Theorem 1	36
4.3.1 Probability $\mathbb{P}_{0,\lambda}$ and \mathbb{P}_λ	36
4.3.2 Discretisation	37
4.3.3 A crucial inequality on $\theta_n^{(\varepsilon)}(\lambda)$	39
4.3.4 Proof of Proposition 4.3.2 by the OSSS inequality	40
4.4 The algorithm T_k	41
4.5 Proof of Lemmas 4.3.3, 4.3.4 and 4.3.5	43
4.5.1 Proof of Lemma 4.3.3	44
4.5.2 Proof of Lemma 4.3.4	44
4.5.3 Proof of Lemma 4.3.5	45

4.6	Proof of (4.15) in Proposition 4.3.1	45
4.6.1	Conclusion of the proof of (4.15) in Proposition 4.3.1	51
4.7	Proof of (4.16) in Proposition 4.3.1	51
5	Left-right crossings in the Miller-Abrahams random resistor network on a Poisson point process	57
5.1	Introduction	57
5.2	Model and main results	60
5.3	Discretization	61
5.3.1	Proof of Proposition 5.3.7	64
5.3.2	Proof of Lemma 5.3.8	64
5.4	Basic geometrical objects in the discrete context	65
5.5	Proof of Proposition 5.4.6	67
5.6	The fundamental lemma	70
5.6.1	Proof of Lemma 5.6.1	72
5.6.2	Proof of Lemma 5.6.3	74
5.7	The sets $E[C, B, B', i]$ and $F[C, B, B', i]$	75
5.8	The success-events S_1 and S_2	76
5.9	The success-event S_3	78
5.10	The success-event S_4	80
5.11	The success-events S_5, S_6 and the occupation of $B(N)$	84
5.12	The success events S_7, S_8	85
5.12.1	Linking $B(2Ne_1, N)$ to $B(3Ne_1, N)$	86
5.12.2	Linking $B(3Ne_1, N)$ to $B(4Ne_1, N)$	87
5.13	Occupation of the box $B(4Ne_1, N)$ after being linked to $B(N)$	88
5.14	Extended construction by success-events	91
5.15	Proof of Theorem 4 in Section 5.3	93
5.16	Proof of Proposition 5.13.5	96

Introduction

During the twentieth century many efforts have been made in the study of the charge transport mechanisms in doped semiconductor at low temperature. Until the middle of the twentieth century it was thought that the conductivity of doped semiconductors should have had an Arrhenius decay when the temperature tends to zero. In 1950 Hung and Gliessmann (see [22]) found a counter-example for such decay studying the conductivity of doped germanium at low temperature and some years later Conwell (see [3]) and Mott (see [25]) gave more evidence for the hopping transport mechanism that have been introduced in those years. Starting from their theories, Miller and Abrahams in 1960 (see [24]) showed that the hopping transport could be studied also in terms of a random resistor network (known as *Miller–Abrahams random resistor network*) and they used the new model to evaluate the conductivity in disordered solids. Nevertheless their model had some deficiencies and was revisited by Mott some years later (see [26], [32, Chapter 13]). In [26] Mott introduced the so called *Mott variable–range hopping* as a transport mechanism to model the phonon-assisted electron transport in disordered solids in the regime of strong Anderson–localization, such as in doped semiconductors. In the same paper, he gave also an heuristic proof for the anomalous behavior of the conductivity. Few years later Ambegoakar, Halperin and Langer (see [1]), Shklovskii and Efros (see [33]), and Pollak (see [30]) have independently modeled Mott variable–range hopping in terms of percolation theory. Other different approaches to this transport mechanism are based on the theory of exclusion processes and random walks (see [15, 18]). In the following we will describe these models, focusing more on the use of the percolation theory, which is the base of the work of this thesis.

Mott variable range hopping and Mott’s law

Doped semiconductors are semiconductors in which atoms of some other materials, called *impurities*, are introduced at random positions $\{x_i\}$. To each impurity it is possible to associate a random variable E_i , called *energy mark*, that takes value in some bounded interval $[-A, A]$. In the strong Anderson–localization regime, a single conduction electron is well described by a quantum wave-function localized around some impurity x_i and E_i is its energy at the ground state.¹ In Mott variable range hopping an electron localized around x_i jumps (by quantum tunneling) to another impurity localized around x_k , if x_k is not occupied by another electron²,

¹To simplify the problem, we consider spinless electrons.

²This constraint is due to Pauli exclusion principle.

with probability rate

$$C(\beta) \exp \left\{ -\frac{2}{\gamma} |x_i - x_k| - \beta \max\{E_k - E_i, 0\} \right\}, \quad (0.1)$$

where β is the inverse temperature, γ is the localization length³ and $C(\beta)$ is a positive term that has a negligible β -dependence w.r.t. the exponential decay. Thinking to work with classical particles instead of localized electrons, such a mechanism can be interpreted as an exclusion process on the sites $\{x_i\}$ with the jump rates from x_i to x_k given by (0.1) if x_k is free.

Calling η a generic configuration in $\{0, 1\}^{\{x_i\}}$, the product measure μ on $\{0, 1\}^{\{x_i\}}$ such that

$$\mu(\eta_{x_i}) = \frac{e^{-\beta(E_i - \pi)}}{1 + e^{-\beta(E_i - \pi)}}$$

is reversible for the exclusion process (see [10]). In the expression above, π is the *chemical potential* and it is determined by the density of conduction electrons. It is possible to take $\pi = 0$ by shifting the energy so that the Fermi energy equals zero.

Since the site disorder makes the problem very challenging, in physics in the regime of low impurity density, the exclusion process on $\{x_i\}$ described above is approximated by independent continuous time random walks for which the probability rate for a jump from x_i to $x_k \neq x_i$ is given by the product

$$\mu(\eta_{x_i} = 1, \eta_{x_k} = 0) \cdot C(\beta) \exp \left\{ -\frac{2}{\gamma} |x_i - x_k| - \beta \max\{E_k - E_i, 0\} \right\}.$$

The independence of the random walks allows to consider only one of them and when the temperature is low, that is for β large, the above jump rate behaves like (see [1, Formula (3.7)])

$$\exp \left\{ -\frac{2}{\gamma} |x_i - x_k| - \frac{\beta}{2} (|E_i| + |E_k| + |E_i - E_k|) \right\}. \quad (0.2)$$

Hence Mott variable-range hopping consists of a random walk in a random spatial and energetic environment given by $\{x_i\}$ and $\{E_i\}$ with jump rate from x_i to x_k given by (0.2).

In this charge transport mechanism, when β is large, arbitrarily long jumps are facilitated if energetically convenient. Indeed it has been proved that such long jumps contribute to most of the charge transport in dimension $d \geq 2$ (see [15], [18]), but not in dimension $d = 1$ (see [2]). This difference has been justified also in physical terms. Indeed, for an isotropic medium and for $d \geq 2$, denoting by \mathbb{I} the d -dimensional identity matrix, the conductivity $\sigma(\beta)$ in doped semiconductors goes to zero as β tends to ∞ following the so called *Mott's law* (or Mott-Efros-Shklovskii law)

$$\sigma(\beta) \sim \exp \left\{ -\kappa \beta^{\frac{\alpha+1}{\alpha+1+d}} \right\} \mathbb{I}, \quad (0.3)$$

where $\kappa > 0$ is a constant and the energy marks are i.i.d. r.v.'s with probability density $\nu(dE) = c(\alpha) E^\alpha \mathbb{1}_{[-A, A]}(E) dE$ for some $A > 0$ and $\alpha \geq 0$ (that are the

³The localization length is the inverse of the rate of decay for the wave function in the strong Anderson localization regime.

significant energy distributions in physics). On the other hand, in dimension $d = 1$, the conductivity has an Arrhenius decay

$$\sigma(\beta) \sim \exp\{-c\beta\}, \quad (0.4)$$

where $c > 0$ is a constant.

The decay (0.3) was derived by Mott, Efros, Shklovskii (see [30], [33]), always in a physical style, through heuristic arguments and by Ambegaokar et al., Miller and Abrahams (see [1] and [24]) using random resistor networks and percolation. The decay (0.4) has been obtained by Kurkijärvi through random resistor network (see [21]) and then it was rigorously proved in [2]. Rigorous derivations of upper and lower bounds in agreement with (0.3) for the diffusion coefficient $d(\beta)$ of the random walk with jump rates (0.2) (called Mott random walk) have been proved in [15] and [18], respectively. Assuming the validity of the Einstein relation $\sigma(\beta) = \beta D(\beta)$ with $D(\beta) := d(\beta)\mathbb{I}$, the same estimates are translated in terms of $\sigma(\beta)$. The constants c at the exponent in (0.3) that appear in the two bounds in [15] and [18] are different. A conjecture for the value of such a constant is given in [11] using percolation and a rigorous proof is given in [14] by using also the results presented in this thesis. For more details about Mott variable-range hopping from a physical point of view we refer to [1, 24, 25, 26, 27, 28, 30, 31, 32, 33].

Basic facts on resistor networks and the Miller–Abrahams random resistor network

As explained at the beginning of the chapter, other approaches to Mott variable-range hopping use the theories of random resistor networks and percolation to derive estimates on the conductivity. The most famous model in this field is the Miller–Abrahams random resistor network, introduced by Miller and Abrahams (see [24]) to investigate the conductivity at low temperature for doped semiconductors in the regime of strong Anderson–localization and low impurity density. This model has been also the starting point for many important works in this context (see [1, 30, 33]). Before describing the Miller–Abrahams random resistor network, we introduce some basic concepts in the theory of resistor networks that will be useful to better understand the problem.

Resistor networks

A *resistor network* is an undirected weighted graph $\mathcal{G} = (\mathcal{V}, \mathcal{E})$ with non-negative weight function $w : \mathcal{E} \rightarrow [0, \infty]$ in which each edge $e \in \mathcal{E}$ with weight $w(e)$ can be seen as a filament with *conductance* $w(e)$. We recall that a conductance $w(e)$ corresponds to a resistance $1/w(e)$, with the convention that $0^{-1} := \infty$ and $\infty^{-1} := 0$. For convenience, we set $w(\{x, y\}) := 0$ if $\{x, y\} \notin \mathcal{E}$.

Let A, B be two disjoint subsets of \mathcal{V} such that each vertex $x \in \mathcal{V}$ is connected to $A \cup B$. The *potential function* with fixed value 0 and 1 in A and B , respectively, is defined as the unique function $u : \mathcal{V} \rightarrow \mathbb{R}$ that satisfies the following properties:

- $u(x) = 0$ if $x \in A$,

- $u(x) = 1$ if $x \in B$,
- for all $x \in \mathcal{V} \setminus (A \cup B)$ the Kirchhoff's law holds:

$$\sum_{y \in \mathcal{V}} w(\{x, y\})(u(x) - u(y)) = 0.$$

Then, given $x, y \in \mathcal{V}$, we define the *current* on the oriented edge (x, y) through Ohm's first law

$$i(x, y) := w(\{x, y\})[u(y) - u(x)].$$

The *effective conductivity* from A to B is defined as the total current flowing out from $A \subset \mathcal{V}$, that is

$$\sigma := \sum_{x \in A} \sum_{y \in \mathcal{V} \setminus A} i(x, y).$$

It is simple to prove that the value of σ is also given by

$$\sigma = \frac{1}{2} \sum_{x, y \in \mathcal{V}} w(\{x, y\})(u(y) - u(x))^2.$$

The *Dirichlet's Principle* gives a variational formula for σ .

Proposition 0.0.1 (Dirichlet's Principle). *Let $g : \mathcal{V} \rightarrow \mathbb{R}$ be a function and let \mathcal{F} be a functional whose value in g is given by*

$$\mathcal{F}(g) := \frac{1}{2} \sum_{x, y \in \mathcal{V}} w(\{x, y\})(g(y) - g(x))^2. \quad (0.5)$$

Let \mathcal{H} be the space of the functions

$$\mathcal{H} := \{g : \mathcal{V} \rightarrow \mathbb{R} \mid g(x) = 0 \text{ if } x \in A, g(x) = 1 \text{ if } x \in B\}. \quad (0.6)$$

Then

$$\sigma = \inf\{\mathcal{F}(g) \mid g \in \mathcal{H}\}.$$

For further properties of random resistor networks we refer to [9].

The Miller–Abrahams random resistor network

Let ξ be a simple point process on \mathbb{R}^d , that is a random locally finite subset of \mathbb{R}^d , and assume that its law is isotropic. We think at the points of ξ as the location of the impurities. Given a realization of ξ , we attach to each vertex $x \in \xi$ a random variable E_x , called energy mark, in such a way that $\{E_x\}_{x \in \xi}$ are i.i.d. r.v.'s with common law ν . This operation is done afresh for any realization of ξ . The Miller–Abrahams random resistor network (MA resistor network, for short) is given by the complete graph on ξ in which to each unordered pair of sites $\{x, y\}$, with $x \neq y$, we associate a filament of conductivity (see [1], [24], [31])

$$c_{x, y} := \exp \left\{ -\frac{2}{\gamma} |x - y| - \frac{\beta}{2} (|E_x| + |E_y| + |E_x - E_y|) \right\}, \quad (0.7)$$

where γ is the localization length in Anderson localization and β is the inverse temperature. In what follows, for simplicity and without loss of generalization, we take $\gamma = 2$.

As explained in [1] one expects that the effective conductivity of the MA resistor network is well approximated by the critical conductance $c_c(\beta)$ as $\beta \rightarrow \infty$. To define such quantity, given a number c_* , we denote by $\mathcal{G}(c_*)$ the subgraph obtained from the MA random resistor network by keeping only the filaments with conductivity at least c_* . The critical conductance is then characterized by the following two conditions:

- (i) for any value $c_* > c_c(\beta)$ a.s. the graph $\mathcal{G}(c_*)$ does not percolate, that is, a.s. it has no unbounded clusters;
- (ii) for any value $c_* < c_c(\beta)$ a.s. the graph $\mathcal{G}(c_*)$ percolates, that is, a.s. it has some unbounded cluster.

In [11, 14] Faggionato derives the Mott's law for $c_c(\beta)$ in the case in which the energy marks have law⁴

$$\nu(dE) = c(\alpha)|E|^\alpha \mathbf{1}_{[-A,A]}(E)dE \quad \text{or} \quad \nu(dE) = c(\alpha)E^\alpha \mathbf{1}_{[0,A]}(E)dE, \quad (0.8)$$

with $A > 0$ and $\alpha \geq 0$, that is, as $\beta \rightarrow \infty$

$$c_c(\beta) \sim \exp \left\{ -\kappa \beta^{\frac{\alpha+1}{\alpha+1+d}} \right\},$$

for some β -independent constant $\kappa > 0$. In particular, if ξ is a homogeneous Poisson point process of density ρ and ν is the first distribution in (0.8), Faggionato has characterized the constant κ in percolation terms as follows

$$\kappa := \exp \left\{ - \left(\frac{\rho_c}{\rho} \right)^{\frac{1}{\alpha+1+d}} (\beta A)^{\frac{\alpha+1}{\alpha+1+d}} \right\}, \quad (0.9)$$

where ρ_c is defined in the following Lemma (proved in [11] as Lemma 2.3).

Lemma 0.0.2. *Consider the graph with vertex set given by the homogeneous Poisson point process ξ on \mathbb{R}^d with density ρ , while the edge set is given by the unordered pairs $\{x, y\}$ of points of ξ such that*

$$|x - y| + |E_x| + |E_y| + |E_x - E_y| \leq 1,$$

where the energy marks $\{E_x\}_{x \in \xi}$ are i.i.d. r.v.'s with law

$$\nu_*(du) = \frac{\alpha + 1}{2} |u|^\alpha \mathbf{1}_{\{-1 \leq u \leq 1\}}(u) du.$$

Then there exists $\rho_c > 0$ such that if $\rho < \rho_c$, then the graph does not percolate a.s., while if $\rho > \rho_c$ then a.s. the graph percolates.

When ν is the section distribution in (0.8) the characterization of κ is similar. In [18] Faggionato et al. provide also arguments that support the universality of the constant κ for ergodic stationary simple point processes on \mathbb{R}^d with density ρ .

⁴These types of laws are the ones relevant in physics.

Our contribution

The rigorous proof of Mott's law and the characterization of the constant κ in (0.3) provided in [14] is a byproduct of results of homogenization and percolation. As already observed in [15] and [18], lower and upper bounds in agreement with Mott's law rely on the analysis, respectively, of the vertex disjoint left-right crossings in $\mathcal{G}(c)$ with $c < c_c(\beta)$, and on the size of the cluster around a generic point in $\mathcal{G}(c)$ when $c > c_c(\beta)$. The lower and upper bounds obtained in [15] and [18] are not close enough up to characterize the constant κ . A more refined analysis of the above percolation properties is necessary to catch the right asymptotic behavior. This analysis is provided in [16] and [17] and furnishes the percolation tools in [14]. Before giving a brief description of such analysis, we formalize the definition of $\sigma(\beta)$ involved in (0.3).

Fixed a positive integer N , let A_N , B_N and Λ_N be subsets of \mathbb{R}^d defined as

$$\begin{aligned} A_N &:= \{x \in \mathbb{R}^d \mid x_1 \leq -N, |x_i| \leq N \text{ for } i = 2, \dots, d\}, \\ B_N &:= \{x \in \mathbb{R}^d \mid x_1 \geq N, |x_i| \leq N \text{ for } i = 2, \dots, d\}, \\ \Lambda_N &:= [-N, N]^d, \end{aligned}$$

and consider their union $D_N := A_N \cup \Lambda_N \cup B_N$. We define $\sigma_N(\beta)$ as the effective conductivity for the resistor network given by the complete graph with vertex set $\xi \cap D_N$ in which to each edge $\{x, y\}$ is associated a filament with conductivity (0.7) when the electrical potential is set equal to 0 on A_N and to 1 on B_N . In [13] Faggionato has proved that \mathbb{P} -a.s. $(2N)^{2-d} \sigma_N(\beta)$ converges to a non-random limit $\sigma(\beta)$ as $N \rightarrow +\infty$.

Let us go back to [16] and [17]. To better describe the results that we have obtained in these papers, we need to introduce some useful definitions. At first, we simplify the notation by taking $\gamma = 2$ and substituting $\frac{\beta}{2}$ with β in (0.7) without loss of generality⁵.

Let ξ be a homogenous Poisson point process on \mathbb{R}^d , $d \geq 2$ with density ρ and let $\{E_x\}_{x \in \xi}$ be a family of i.i.d. random variables with law ν that is independent of ξ . Fixed some positive constant $\zeta > 0$, define the graph $\mathcal{G}_{\zeta, \beta, \rho}$ that has ξ as vertex set, while the edge set is given by the unordered pairs $\{x, y\}$ that satisfy

$$|x - y| + \beta(|E_x| + |E_y| + |E_x - E_y|) \leq \zeta. \quad (0.10)$$

Note that $\mathcal{G}_{\zeta, \beta, \rho}$ is the subgraph of the MA resistor network that has ξ as vertex set and edge set given by the filaments with conductivity at least $e^{-\zeta}$.

In [16] we have discussed the phase transition for this graph when varying ζ and we have also proved that the phase transition is sharp, under some assumptions on the law ν of the energy marks. More precisely, without loss of generality, we have studied the graph $\mathcal{G}_{\zeta, 1, \rho}$ instead of $\mathcal{G}_{\zeta, \beta, \rho}$ and, assuming a polynomial probability distribution ν as in (0.8), we have used the existence of the scaling proposed in [11] to study the phase transition varying ρ and fixing ζ instead of varying ζ and fixing ρ . In this framework it is easy to construct a coupling under which the graph $\mathcal{G}_{\zeta, 1, \rho}$ is

⁵We still think of β as the inverse temperature.

sandwiched between two realizations of two different Boolean models with different fixed deterministic radius. Since it is well known that such a model has a phase transition when varying the density of the point process (see [23]), we have deduced (see [16, Proposition 2.2]) that if ν satisfies

$$\nu \left(\left[-\frac{\zeta}{2}, \frac{\zeta}{2} \right] \right) > 0, \quad (0.11)$$

then there exists $\rho_c \in (0, +\infty)$ such that the graph $\mathcal{G}_{\zeta,1,\rho}$ percolates a.s. if $\rho > \rho_c$ and it does not percolate a.s. if $\rho < \rho_c$.

This information is not enough to obtain an upper bound for the conductivity and for this reason we have investigated more the phase transition studying the connection probabilities in the subcritical regime. Indeed they are key instruments to understand the size of clusters in the subcritical regime. In particular, by applying the method of randomized algorithms recently developed by Duminil–Copin et al. (see [5, 6]), we have proved that the phase transition is sharp, that is the probability that points at uniform distance n are connected in $\mathcal{G}_{\zeta,1,\rho}$ decays exponentially fast in n as $n \rightarrow \infty$. The method of randomized algorithms allows to obtain estimates on the probability of “increasing” events applying the OSSS inequality (see [29]). A key feature of this method is that it relates the variance of the characteristic function of the event under consideration with specific properties (influence and revealement) of the random algorithm that we use to discover whether or not this event occurs. In order to give a gentle presentation of the method of randomized algorithms, in Chapter 3 we discuss its application to the Bernoulli bond percolation on \mathbb{Z}^d (cf. [4]). Indeed in [4] Duminil–Copin shows how the proof of Menshikov’s theorem (see [19, Theorem 5.4]) can be really simplified. As explained in [29], to apply the method we need a product probability space and, since this is not the case for $\mathcal{G}_{\zeta,1,\rho}$, as suggested in [6], we use a discretization of the model that allows to approximate $\mathcal{G}_{\zeta,1,\rho}$ with a graph built on the grid $\varepsilon\mathbb{Z}^d$. The smaller ε is, the better the approximation will be. Hence, applying the randomized algorithm method to the discrete model and then letting ε tend to 0, we have proved the sharpness of the phase transition for the original model. Another technical difficulty that we have faced in this paper is related to the fact that the event “there is a point of ξ at the origin” has zero probability and hence the event “the origin is connected to points at uniform distance at least n ” has zero probability too. For this reason it has been necessary to work with the Palm distribution and use the Palm formula (see [8, Formula (12.2.4), Theorem 12.2.II]). In the case of the homogeneous Poisson point process ξ , the Palm distribution becomes the law of the point process given by $\tilde{\xi} := \xi \cup \{0\}$ in which we add to ξ a point at the origin. Let us call by $\mathbb{P}_{0,\rho}$ the law of $\mathcal{G}_{\zeta,1,\rho}$ with $\tilde{\xi}$ as vertex set. In [16, Theorem 1] we have proved the following theorem.

Theorem 0.0.3. *Call $h : (0, +\infty) \rightarrow [0, 1]$ the function defined as the probability of the event $\{|E| + |E'| + |E - E'| \leq \zeta - u\}$, where E, E' are i.i.d. r.v.’s with law ν . Suppose that h is such that there exists a finite family of points $0 < r_1 < r_2 < \dots < r_{m-1} < r_m$ such that*

- $h(r) = 0$ for all $r \geq r_m$;
- h is uniformly continuous in (r_i, r_{i+1}) for all $i = 0, \dots, m - 1$, where $r_0 = 0$.

Then the following statements hold:

- for any $\rho < \rho_c$ there exists $c = c(\rho) > 0$ such that

$$\mathbb{P}_{0,\rho}(0 \leftrightarrow S_n) \leq e^{-cn}, \quad \forall n \in \mathbb{N};$$

- there exists $C > 0$ such that

$$\mathbb{P}_{0,\rho}(0 \leftrightarrow \infty) \geq C(\rho - \rho_c), \quad \forall \rho > \rho_c,$$

where the event $\{0 \leftrightarrow S_n\}$ occurs when there exists a path in $\mathcal{G}_{\zeta,1,\rho}$ from 0 to points in the complementary of the box $(-n, n)^d$, while the event $\{0 \leftrightarrow \infty\}$ is equivalent to the fact that 0 is connected in $\mathcal{G}_{\zeta,1,\rho}$ to points of the graph that are arbitrarily far from it.

The above condition on ν is satisfied in particular by the distributions in (0.8). We point out that in [16] we have proved also a result similar to the above theorem for the random connection model and the Boolean model with uniformly bounded edges. Actually, in the case of the Boolean model, a more powerful result has been obtained by Duminil–Copin et al. in [7] and by Ziesche in [35] after the submission of [16] on arXiv.

We point out that all the results in [16] that we have briefly described above will be analyzed in a deeper way in Chapter 4, which consists of the article [16], published on ALEA in 2019.

The analysis of the left-right crossings in $\mathcal{G}_{\zeta,1,\rho}$ in the supercritical regime has been done in [17]. The main result in this paper states that in this regime, apart an event of exponentially small probability, the maximal number of vertex disjoint left-right crossings of a box of size n in the graph $\mathcal{G}_{\zeta,1,\rho}$ is typically lower bounded by $O(n^{d-1})$. More precisely, let $\zeta_c > 0$ be the critical value for which $\mathcal{G}_{\zeta,1,\rho}$ percolates a.s. if $\zeta > \zeta_c$ and it does not percolate a.s. if $\zeta < \zeta_c$ (we recall that the existence of ζ_c has been proved in [11]). Given $L > 0$, a *left-right crossing* of the box $[-L, L]^d$ in the graph $\mathcal{G}_{\zeta,1,\rho}$ is given by any sequence of distinct points $x_1, x_2, \dots, x_n \in \xi$ such that

- $\{x_i, x_{i+1}\}$ is an edge of $\mathcal{G}_{\zeta,1,\rho}$ for all $i = 1, 2, \dots, n-1$;
- $x_1 \in (-\infty, -L) \times [-L, L]^{d-1}$;
- $x_2, x_3, \dots, x_{n-1} \in [-L, L]^d$;
- $x_n \in (L, +\infty) \times [-L, L]^{d-1}$.

We also define $R_L(\mathcal{G}_{\zeta,1,\rho})$ as the maximal number of vertex-disjoint left-right crossings of $[-L, L]^d$ in $\mathcal{G}_{\zeta,1,\rho}$. The main result in [17] is the following.

Theorem 0.0.4. *Suppose that ν has bounded support contained in $[0, +\infty)$ and that 0 belongs to the support of ν . Then, given $\rho > 0$ and $\zeta > \zeta_c$, there exist positive constants c, c' such that*

$$\mathbb{P}\left(R_L(\mathcal{G}_{\zeta,1,\rho}) \geq cL^{d-1}\right) \geq 1 - e^{-c'L^{d-1}}, \quad (0.12)$$

for L large enough, where $\mathbb{P}(\cdot)$ is the law of the graph $\mathcal{G}_{\zeta,1,\rho}$.

The proof of this theorem follows the renormalization technique introduced by Grimmett and Marstrand in [20] to prove that the critical probability for the bond percolation on a slab of \mathbb{Z}^d converges to the critical probability for the bond percolation on \mathbb{Z}^d when the thickness of the slab goes to $+\infty$. More precisely, after a discretization procedure that reduces the original problem to a similar one on the grid $\varepsilon\mathbb{Z}^d$, we have combined the renormalization method of Grimmett and Mastrandt in [20] with a procedure introduced by Tanemura in [34, Section 4] to study the left-right crossings in the supercritical regime for a Boolean model with deterministic radius. The application of these two techniques to our case has not been straightforward due to spatial correlations in the MA resistor network. The main technical novelty in [17] is that we have built a quasi-cluster in our graph through a renormalization procedure similar to the one described in [20]. By “quasi-cluster” in our graph we mean a cluster that is not necessarily connected as in [20] and can present some cuts in suitable localized regions. This construction has been realized by expressing the Poisson point process of density ρ as superposition of two independent Poisson point processes with density $\rho - \delta$ and δ , respectively. Indeed the quasi-cluster is composed by disjoint clusters made only by points of the point process of density $\rho - \delta$. Then the above superposition creates junctions between these disconnected clusters using points of the point process of density δ with very small mark. The final geometrical set obtained from the quasi-cluster by adding the above junctions is connected and provides by construction a set of vertex-disjoint left-right crossings of the right cardinality.

We underline that the renormalization method in [20] uses the FKG inequality. In our case we can introduce a natural ordering of the random objects, but the FKG inequality is valid only in the case in which the energy marks are a.s. nonnegative, since in that case the energy-term in (0.10), that is $|E_x| + |E_y| + |E_x - E_y|$, reduces to $2 \max\{E_x, E_y\}$ which is increasing in the variables E_x and E_y . So Theorem 0.0.4 can be applied only in the case of energy marks with probability distributions of the second form in (0.8). Even if this second type of distributions does not cover all the interesting physical cases, it shares with the physical distributions (the ones of the first form in (0.8)) several scaling properties which are relevant in the heuristic derivation of Mott’s law.

We point out that all the results in [17] that we have briefly described above will be analyzed in a deeper way in Chapter 5, which consists of the paper [17], that will be submitted soon on arXiv.

Outline of the thesis

In Chapters 1 and 2 we give, respectively, a brief introduction to point processes and percolation theory. In Chapter 3 we introduce the reader to randomized algorithms through their application to the Bernoulli bond percolation. In Chapters 4 and 5 we show the results that we have obtained in [16] and [17], respectively.

Bibliography

- [1] V. Ambegoakar, B.I. Halperin, J.S. Langer. *Hopping Conductivity in Disordered Systems*. Phys, Rev B, **4**, pp. 2612–2620 (1971).
- [2] P. Caputo, A. Faggionato. *Diffusivity in one-dimensional generalized Mott variable-range hopping models*. Ann. Appl. Probab., **19**, pp. 1459–1494 (2009).
- [3] E.M. Conwell. *Impurity Band Conduction in Germanium and Silicon*. Phys. Rev., **103(1)**, pp. 51–61 (1956).
- [4] H. Duminil-Copin. *Lectures on the Ising and Potts models on the hypercubic lattice*. Preprint available on arXiv as arXiv:1707.00520 (2017).
- [5] H. Duminil-Copin, A. Raoufi, V. Tassion. *Sharp phase transition for the random-cluster and Potts models via decision trees*. Ann. of Math., **189** (1), pp. 75–99 (2019).
- [6] H. Duminil-Copin, A. Raoufi, V. Tassion. *Exponential decay of connection probabilities for subcritical Voronoi percolation in \mathbb{R}^d* . To appear on Prob. Theory Rel. Fields., **173**, Issue 1-2, pp. 479–490 (2019).
- [7] H. Duminil-Copin, A. Raoufi, V. Tassion. *Subcritical phase of d -dimensional Poisson-Boolean percolation and its vacant set*. Preprint available on arXiv as arXiv:1805.00695 (2018).
- [8] D.J. Daley, D. Vere-Jones. *An Introduction to the Theory of Point Processes*. New York, Springer Verlag (1988).
- [9] P.G. Doyle, J.L. Snell. *Random Walks and Electric Networks*. Cambridge University Press (1984).
- [10] A. Faggionato. *1D Mott Variable-Range Hopping with External Field*. Published in *Stochastic Dynamics Out of Equilibrium: Institut Henri Poincaré, Paris, France, 2017*. Springer Proceedings in Mathematics & Statistics, **282**, pp. 550–559 (2019).
- [11] A. Faggionato. *Mott’s law for the effective conductance of the Miller–Abrahams random resistor network*. In preparation. A preliminary version is available online as arXiv:1712.07980 (2018).
- [12] A. Faggionato. *Stochastic homogenization in amorphous media and applications to exclusion processes*. Preprint, arXiv:1903.07311 (2019).
- [13] A. Faggionato. *Miller–Abrahams random resistor network, Mott random walk and 2-scale homogenization*. Forthcoming.
- [14] A. Faggionato. *Mott’s law for Miller–Abrahams random resistor network and for Mott random walk*. In preparation.
- [15] A. Faggionato, P. Mathieu. *Mott law as upper bound for a random walk in a random environment*. Comm. Math. Phys. **281**, pp. 263–286 (2008).

Bibliography

- [16] A. Faggionato, H.A. Mimun. *Connection probabilities in Poisson random graphs with uniformly bounded edges*. ALEA, Volume XVI, pp. 463–486 (2019).
- [17] A. Faggionato, H.A. Mimun. *Left-right crossings in the Miller-Abrahams random resistor network on a Poisson point process*. Forthcoming.
- [18] A. Faggionato, H. Schulz–Baldes, D. Spehner. *Mott law as lower bound for a random walk in a random environment*. Comm. Math. Phys., **263**, pp. 21–64 (2006).
- [19] G.R. Grimmett, *Percolation*. Die Grundlehren der mathematischen Wissenschaften **321**. Second edition, Springer Verlag, Berlin (1999).
- [20] G.R. Grimmett, J.M. Marstrand. *The supercritical phase transition of percolation is well behaved*. Proceedings: Mathematical and Physical Sciences, Vol. 430, No. 1879, pp. 439–457 (1990).
- [21] J. Kurkijärvi. *Hopping conductivity in one dimension*. Phys. Rev. B, **8**, pp. 922–924 (1973).
- [22] C.S. Hung, J.R. Gliessmann. *The Resistivity and Hall Effect of Germanium at Low Temperatures*. Phys. Rev., **79**, pp. 726–727 (1950).
- [23] R. Meester, R. Roy. *Continuum percolation*. Cambridge Tracts in Mathematics **119**. First edition, Cambridge University Press, Cambridge (1996).
- [24] A. Miller, E. Abrahams. *Impurity Conduction at Low Concentrations*. Phys. Rev., **120**, pp. 745–755 (1960).
- [25] N.F. Mott. *On the transition to metallic conduction in semiconductors*, Can. J. Phys., **34**, pp. 1356–1368 (1956).
- [26] N.F. Mott. *Conduction in glasses containing transition metal ions*, J. Non-Crystal. Solids, **1**, 1–17 (1968).
- [27] N.F. Mott. *Conduction in non-crystalline materials III. Localized states in a pseudogap and near extremities of conduction and valence bands*, Phil. Mag. **19**, pp. 835–852 (1969).
- [28] N.F. Mott, E.A. Davis. *Electronic Processes in Non-Crystalline Materials*, New York, Oxford University Press (1979).
- [29] R. O’Donnell, M. Saks, O. Schramm, R. Servedio. *Every decision tree has an influential variable*. FOCS’05, pp. 31–39 (2005).
- [30] M. Pollak. *The Metal–Non-metal Transition in Disordered Systems*, edited by L.R. Friedman and D.P. Tunstall, University of Edinburgh, pp. 95 (1978).
- [31] M. Pollak, M. Ortuño, A. Frydman. *The Electron Glass*, Cambridge University Press, United Kingdom, first edition (2013).
- [32] M. Sahimi. *Applications of Percolation Theory*, Taylor & Francis, first edition (1994).

- [33] S. Shklovskii, A.L. Efros. *Electronic Properties of Doped Semiconductors*. Springer Verlag, Berlin, first edition (1984).
- [34] H. Tanemura. *Behavior of the Supercritical Phase of a Continuum Percolation Model on \mathbb{R}^d* . Journal of Applied Probability, Vol. 30, No. 2, pp. 382–396 (1993).
- [35] S. Ziesche. *Sharpness of the phase transition and lower bounds for the critical intensity in continuum percolation on \mathbb{R}^d* . Ann. Inst. H. Poincaré Probab. Statist., **54**, pp. 866–878 (2018).

Chapter 1

Marked simple point processes

In this chapter we introduce the theory of the marked simple point processes giving just the statements of some important results and referring to [1] for the proofs. Note that in [1] many results are written for simple point processes, but, as pointed out by the authors, they can be extended to the context of marked simple point processes with some slight changes.

Let \mathcal{K} be a Polish space, i.e. a complete separable metric space, endowed with a metric $d_{\mathcal{K}}$.

We define a metric d on the space $\mathbb{R}^d \times \mathcal{K}$ as follows: for any $(x, k), (y, j) \in \mathbb{R}^d \times \mathcal{K}$

$$d((x, k), (y, j)) := \max\{|x - y|, d_{\mathcal{K}}(k, j)\},$$

where $|\cdot|$ is the euclidean norm on \mathbb{R}^d .

Note that $\mathbb{R}^d \times \mathcal{K}$ is a Polish space endowed with the metric d since it is the product of two Polish spaces (see [2, Proposition 3.3 (iii)]).

In the following, given a topological space S , we denote by $\mathcal{B}(S)$ the Borel σ -algebra on S .

1.1 Counting measures and marked simple point processes

Definition 1.1.1 (Boundedly finite measure). *A Borel measure μ on $\mathbb{R}^d \times \mathcal{K}$ is called boundedly finite if $\mu(A) < \infty$ for every bounded Borel set $A \subset \mathbb{R}^d \times \mathcal{K}$.*

We denote by \mathcal{M} the space of the boundedly finite measures on $\mathbb{R}^d \times \mathcal{K}$.

As in [1, Section A2.6], we can define a metric \hat{d} on \mathcal{M} as an extension of the Prohorov metric in the space of the finite measures on $\mathbb{R}^d \times \mathcal{K}$. More precisely, given $\mu, \nu \in \mathcal{M}$, denoting respectively by $\mu^{(r)}, \nu^{(r)}$ the restrictions of μ and ν to the ball $B_r((x_0, k_0)) \subset \mathbb{R}^d \times \mathcal{K}$ for some $(x_0, k_0) \in \mathbb{R}^d \times \mathcal{K}$ and some $r \in (0, +\infty)$, we define the distance between μ and ν as

$$\hat{d}(\mu, \nu) = \int_0^\infty e^{-r} \frac{\tilde{d}(\mu^{(r)}, \nu^{(r)})}{1 + \tilde{d}(\mu^{(r)}, \nu^{(r)})} dr, \quad (1.1)$$

where \tilde{d} is the Prohorov metric on the space of the totally finite measures on $\mathbb{R}^d \times \mathcal{K}$ (see [1, Formula (A2.5.1)]), that is

$$\tilde{d}(\mu^{(r)}, \nu^{(r)}) := \inf\{\varepsilon : \varepsilon \geq 0 \text{ and for all closed } F \subset (\mathbb{R}^d \times \mathcal{K}) \cap B_r((x_0, k_0)) \text{ it holds} \\ \mu^{(r)}(F) \leq \nu^{(r)}(F^\varepsilon) + \varepsilon, \nu^{(r)}(F) \leq \mu^{(r)}(F^\varepsilon) + \varepsilon\}, \quad (1.2)$$

with $F^\varepsilon := \{(x, k) \in \mathbb{R}^d \times \mathcal{K} \mid \exists (y, j) \in F \text{ such that } d((x, k), (y, j)) < \varepsilon\}$.

Since $\mathbb{R}^d \times \mathcal{K}$ is a Polish space, one can proceed as in [1, Section A2.6] to prove that \tilde{d} is indeed a metric and it induces on \mathcal{M} a topology that does not depend on the choice of the point $(x_0, k_0) \in \mathbb{R}^d \times \mathcal{K}$. Moreover such a topology makes \mathcal{M} a Polish space (see [1, Theorem A2.6.III]) and the convergence with respect to \tilde{d} can be characterized in many ways described in the following result (see [1, Proposition A2.6.II]).

Proposition 1.1.2. *Let $\{\mu_k\}_{k \in \mathbb{N}}$ and μ be measures on \mathcal{M} . Then the following statements are equivalent:*

- (i) $\hat{d}(\mu_k, \mu) \rightarrow 0$;
- (ii) $\int_{\mathbb{R}^d \times \mathcal{K}} f(x) \mu_k(dx) \rightarrow \int_{\mathbb{R}^d \times \mathcal{K}} f(x) \mu(dx)$ for all bounded continuous functions f on $\mathbb{R}^d \times \mathcal{K}$ vanishing outside a bounded set;
- (iii) there exists a sequence of balls $B_n \uparrow \mathbb{R}^d \times \mathcal{K}$ as $n \rightarrow \infty$ such that, if $\mu_k^{(n)}, \mu^{(n)}$ denote the restrictions of the measures μ_k, μ to B_n , then $\tilde{d}(\mu_k^{(n)}, \mu^{(n)}) \rightarrow 0$ as $k \rightarrow \infty$ for any $n \in \mathbb{N}$;
- (iv) $\mu_k(A) \rightarrow \mu(A)$ for all bounded Borel set $A \subset \mathbb{R}^d \times \mathcal{K}$ with $\mu(\partial A) = 0$.

The counting measures on $\mathbb{R}^d \times \mathcal{K}$ are a particular type of boundedly finite measures on $\mathbb{R}^d \times \mathcal{K}$ as stated in the following definition.

Definition 1.1.3 ((Simple) counting measure). *A boundedly finite measure μ is called counting measure if $\mu(A) \in \mathbb{N}$ for any bounded Borel set $A \subset \mathbb{R}^d \times \mathcal{K}$. In particular a counting measure μ is said to be simple if $\mu(\{(x, k) \mid k \in \mathcal{K}\}) \in \{0, 1\}$ for any $(x, k) \in \mathbb{R}^d \times \mathcal{K}$.*

We denote by \mathcal{N} and $\tilde{\mathcal{N}}^\#$ the spaces of the counting measures and simple counting measures on $\mathbb{R}^d \times \mathcal{K}$, respectively. In particular we have $\tilde{\mathcal{N}}^\# \subset \mathcal{N} \subset \mathcal{M}$.

There exists a bijective application that allows to write any $\mu \in \mathcal{N}$ as sum of Dirac measures on $\mathbb{R}^d \times \mathcal{K}$ and, in particular, it is also a bijection between $\tilde{\mathcal{N}}^\#$ and the locally finite subsets of $\mathbb{R}^d \times \mathcal{K}$. More precisely, a boundedly finite measure μ is an element of \mathcal{N} if and only if there exists a locally finite countable set of points $\{(x_i, k_i)\}_i \subset \mathbb{R}^d \times \mathcal{K}$ and a set of positive integers $\{c_i\}_i$ such that $\mu = \sum_i c_i \delta_{(x_i, k_i)}$. In particular if $\mu \in \mathcal{N}$ is simple, then $\mu = \sum_i \delta_{(x_i, k_i)}$ (see [1, Proposition 7.1.II]) and we can associate to such a measure a unique locally finite set given by $\{(x_i, k_i)\}_i$. If $(x, k) \in \{(x_i, k_i)\}_i$, we say that x is a point of μ and k is the *mark* of the point at x .

The space \mathcal{N} inherits many properties by \mathcal{M} . Indeed, since \mathcal{N} is a closed subset of \mathcal{M} (see [1, Proposition 7.1.III]), it is also a Polish space endowed with the metric

\hat{d} (see [2, Proposition 3.3 (ii)] and [1, Corollary 7.1.IV]). Moreover one can show that the Borel σ -algebra on \mathcal{N} , that we denote by $\mathcal{B}(\mathcal{N})$, is generated by the sets $\{\mu(A) = c\}$, where $\mu \in \mathcal{N}$, A is a Borel subset of $\mathbb{R}^d \times \mathcal{K}$ and $c \in \mathbb{N}$ (see [1, Corollary 7.1.VI]).

Many properties of \mathcal{N} can be stated also for its subset $\tilde{\mathcal{N}}^\#$. Indeed $\tilde{\mathcal{N}}^\#$, as subset of \mathcal{N} , is separable too (see [2, Section 1.B]), but it is not closed (see [1, Section 7.1]). Moreover the Borel σ -algebra on $\tilde{\mathcal{N}}^\#$, that we denote by $\mathcal{B}(\tilde{\mathcal{N}}^\#)$, is generated by the sets $\{\mu(A) = c\}$, where $\mu \in \tilde{\mathcal{N}}^\#$, A is a Borel subset of $\mathbb{R}^d \times \mathcal{K}$ and $c \in \mathbb{N}$.

Definition 1.1.4 (Point process). *A point process $\boldsymbol{\mu}$ on $\mathbb{R}^d \times \mathcal{K}$ is a measurable mapping from a probability space $(\Omega, \mathcal{F}, \mathbb{P})$ into $(\mathcal{N}, \mathcal{B}(\mathcal{N}))$. In the whole chapter we will denote by bold character $\boldsymbol{\mu}$ the point process, while we write μ for its realizations (which are elements of \mathcal{N}).*

Definition 1.1.5. *We define the Borel subset $\mathcal{N}^\#$ of $\tilde{\mathcal{N}}^\#$ as the set made by the simple counting measures μ for which $\mu(\{(x, k_1)\}) = 1 = \mu(\{(x, k_2)\})$ for some $x \in \mathbb{R}^d$ and some $k_1, k_2 \in \mathcal{K}$ if and only if $k_1 = k_2$.*

In simple words, $\mathcal{N}^\#$ is made by the simple counting measures $\mu = \sum_i \delta_{(x_i, k_i)}$ for which there do not exist two points of $\mathbb{R}^d \times \mathcal{K}$ contained in $\{(x_i, k_i)\}_i$ with the same positions and different marks. Since $\mathcal{N}^\#$ is a subset of the separable space $\tilde{\mathcal{N}}^\#$, we have that $\mathcal{N}^\#$ is separable too. Moreover the Borel σ -algebra on $\mathcal{N}^\#$, that we denote by $\mathcal{B}(\mathcal{N}^\#)$, is generated by the sets $\{\mu(A) = c\}$, where $\mu \in \mathcal{N}^\#$, A is a Borel subset of $\mathbb{R}^d \times \mathcal{K}$ and $c \in \mathbb{N}$.

Any element of $\mathcal{N}^\#$ can be considered as a realization of a marked simple point process on \mathbb{R}^d with marks in \mathcal{K} . More precisely we have the following definition.

Definition 1.1.6 (Marked simple point process). *A marked simple point process $\boldsymbol{\mu}$ on \mathbb{R}^d with marks in \mathcal{K} is a measurable mapping from a probability space $(\Omega, \mathcal{F}, \mathbb{P})$ into $(\mathcal{N}^\#, \mathcal{B}(\mathcal{N}^\#))$.*

In the whole chapter we will denote by bold character $\boldsymbol{\mu}$ the point process, while we write μ for its realizations (which are elements of $\mathcal{N}^\#$). Moreover we will denote by \mathbb{P} the law of $\boldsymbol{\mu}$ and by $\mathbb{E}[\cdot]$ the expectation associated with the law \mathbb{P} .

Remark 1.1.7. *If the set \mathcal{K} contains only one point, the marked simple point process reduces to the so called simple point process on \mathbb{R}^d . Indeed \mathbb{R}^d is isomorphic to $\mathbb{R}^d \times \mathcal{K}$ when \mathcal{K} has only one element and a simple point process on \mathbb{R}^d is defined as a measurable mapping from a probability space into the space of the simple counting measures on \mathbb{R}^d .*

It is possible to describe a point process by a family of integer-valued random variables (see [1, Proposition 7.1.IX]). Indeed, given a family of integer-valued random variables defined on the same probability space

$$\{N_A \mid A \text{ is a Borel subset of } \mathbb{R}^d \times \mathcal{K}\},$$

there exists a point process $\boldsymbol{\mu}$ on $\mathbb{R}^d \times \mathcal{K}$ such that $\boldsymbol{\mu}(A) = N_A$ almost surely if and only if the following statements are satisfied:

- $N_{A \cup B} = N_A + N_B$ almost surely for any pairs of disjoint bounded Borel sets $A, B \subset \mathbb{R}^d \times \mathcal{K}$;
- for all sequences $\{A_n\}_n$ of bounded Borel subsets of $\mathbb{R}^d \times \mathcal{K}$ with $A_n \downarrow \emptyset$ we have $N_{A_n} \rightarrow 0$ almost surely, where $A_n \downarrow \emptyset$ if the sequence $\{\mathbb{1}_{A_n}\}$ of the indicator functions of the sets $\{A_n\}$ satisfies

$$\limsup_{n \rightarrow \infty} \mathbb{1}_{A_n} = 0.$$

One can characterize the distribution of a point process by the finite dimensional (fidi for short) distributions (see [1, Proposition 6.2.III]): for bounded Borel subsets $\{A_i\}_i$ of $\mathbb{R}^d \times \mathcal{K}$ and nonnegative integers $\{n_i\}_i$, we define

$$P_k(A_1, \dots, A_k; n_1, \dots, n_k) = \mathbb{P}(\mu(A_i) = n_i \text{ for } i = 1, \dots, k).$$

The following theorem is an existence result for such distributions (see [1, Theorem 7.1.XI]).

Theorem 1.1.8. *A family $\{P_k(A_1, \dots, A_k; n_1, \dots, n_k)\}$ of discrete fidi distributions defined on bounded Borel subsets of $\mathbb{R}^d \times \mathcal{K}$ is the family of fidi distributions of a point process if and only if the following statements are satisfied:*

(i) *for any permutation i_1, \dots, i_k of the indexes $1, \dots, k$, we have*

$$P_k(A_1, \dots, A_k; n_1, \dots, n_k) = P_k(A_{i_1}, \dots, A_{i_k}; n_{i_1}, \dots, n_{i_k});$$

(ii) $\sum_{r=0}^{\infty} P_k(A_1, \dots, A_{k-1}, A_k; n_1, \dots, n_{k-1}, r) = P_{k-1}(A_1, \dots, A_{k-1}; n_1, \dots, n_{k-1})$;

(iii) *for each disjoint pair A_1, A_2 of bounded Borel subsets $\mathbb{R}^d \times \mathcal{K}$ we have that $P_3(A_1, A_2, A_1 \cup A_2; n_1, n_2, n_3) = 0$ if $n_3 \neq n_1 + n_2$;*

(iv) *for sequences $\{A_n\}$ of bounded Borel subsets of $\mathbb{R}^d \times \mathcal{K}$ with $A_n \downarrow \emptyset$ as $n \rightarrow \infty$, we have $P_1(A_n; 0) \rightarrow 0$ as $n \rightarrow \infty$.*

Definition 1.1.9 (Intensity measure). *We define the intensity measure of a marked simple point process μ as the set function $M(\cdot) := \mathbb{E}[\mu(\cdot \times \mathcal{K})]$ on $\mathcal{B}(\mathbb{R}^d)$.*

In the rest we restrict without further mention to marked simple point processes such that $M(\cdot)$ is bounded on bounded Borel subsets A of \mathbb{R}^d . Note that in this case $M(\cdot)$ is a boundedly finite measure on \mathbb{R}^d .

1.2 Stationarity and ergodicity

Given $x \in \mathbb{R}^d$ we define the translation operator $T_x : \mathcal{B}(\mathbb{R}^d \times \mathcal{K}) \rightarrow \mathcal{B}(\mathbb{R}^d \times \mathcal{K})$ as

$$T_x : A \mapsto T_x A := \{(x + z, k) \in \mathbb{R}^d \times \mathcal{K} \mid (z, k) \in A\} \quad (1.3)$$

for any $A \in \mathcal{B}(\mathbb{R}^d \times \mathcal{K})$. Moreover for any $B \in \mathcal{B}(\mathbb{R}^d)$ and $x \in \mathbb{R}^d$, we denote by $x + B$ (or equivalently $B + x$) the set $\{x + y \mid y \in B\}$.

1.2 Stationarity and ergodicity

The operator T_x induces a transformation $S_x : \mathcal{N}^\# \rightarrow \mathcal{N}^\#$ through the relation

$$(S_x \mu)(A) = \mu(T_x A)$$

for any $\mu \in \mathcal{N}^\#$ and $A \in \mathcal{B}(\mathbb{R}^d \times \mathcal{K})$, that is

$$S_x \mu = \sum_i \delta_{(x_i - x, k_i)} \quad \text{if } \mu = \sum_i \delta_{(x_i, k_i)}.$$

In the following we denote by $S_x \mu$ the random variable whose image is given by $S_x \mu$ whenever μ is the realization of μ . Moreover, for any $A \in \mathcal{B}(\mathcal{N}^\#)$, we denote by $S_x A$ the set $\{S_x \mu \mid \mu \in A\}$.

Since $S_x : \mathcal{N}^\# \rightarrow \mathcal{N}^\#$ is continuous (see [1, Lemma 10.1.I]), if μ is a marked simple point process, then $S_x \mu$ is obtained by the composition of two measurable mappings and hence $S_x \mu$ is a marked simple point process.

Definition 1.2.1 (Stationary marked simple point process). *A marked simple point process μ on \mathbb{R}^d with marks in \mathcal{K} (or equivalently, its law \mathbb{P}) is called stationary (with respect to the shifts $\{S_x\}$ for $x \in \mathbb{R}^d$) if, for all $x \in \mathbb{R}^d$, μ and $S_x \mu$ have the same law. Equivalently, μ is stationary if the fidi distributions of μ and $S_x \mu$ coincide, that is*

$$P_k(A_1, \dots, A_k; n_1, \dots, n_k) = P_k(T_x A_1, \dots, T_x A_k; n_1, \dots, n_k)$$

for any bounded Borel subsets $\{A_i\}_i$ of $\mathbb{R}^d \times \mathcal{K}$ and nonnegative integers $\{n_i\}_{i=1}^k$.

The previous definition can be written in a more compact way by defining another operator \hat{S}_x that operates on the probability measures on the Borel sets of $\mathcal{N}^\#$: for any Borel subset B of $\mathcal{N}^\#$, we define

$$\hat{S}_x \mathbb{P}(B) := \mathbb{P}(S_x B).$$

In such terms, Definition 1.2.1 can be read as follows: μ is stationary if its law on $\mathcal{N}^\#$ is invariant under shifts $\{\hat{S}_x\}$, that is $\hat{S}_x \mathbb{P}(B) = \mathbb{P}(B)$ for any Borel subset of $\mathcal{N}^\#$ and for any $x \in \mathbb{R}^d$.

An important consequence of the stationarity is that a stationary marked simple point process μ cannot have realizations with a finite positive number of points in the whole space \mathbb{P} -almost surely, that is (see [1, Proposition 10.1.IV])

$$\mathbb{P}(\mu(\mathbb{R}^d \times \mathcal{K}) \in \{0, \infty\}) = 1.$$

Moreover if μ is stationary, the intensity measure M (see Definition 1.1.9) has a more explicit structure, as stated in the following result.

Proposition 1.2.2. *If μ is a stationary marked simple point process and $M([0, 1]^d) = \lambda \in (0, +\infty)$, then for any $A \in \mathcal{B}(\mathbb{R}^d)$*

$$M(A) = \lambda l(A),$$

where $l(\cdot)$ is the Lebesgue measure on \mathbb{R}^d .

Proof. Since μ is stationary, we have

$$M(A) = \mathbb{E}[\mu(A \times \mathcal{K})] = \mathbb{E}[\mu(T_x(A \times \mathcal{K}))] = \mathbb{E}[\mu((A + x) \times \mathcal{K})] = M(A + x)$$

for any $A \in \mathcal{B}(\mathbb{R}^d)$ and $x \in \mathbb{R}^d$. Then M is a translation invariant measure on \mathbb{R}^d and hence it is a multiple of the Lebesgue measure, that is $M(A) = \lambda l(A)$ for some $\lambda \in \mathbb{R} \cup \{\infty\}$. Since by hypothesis $M([0, 1]^d) \in (0, +\infty)$, we get that $\lambda \in (0, +\infty)$. \square

We now move to ergodic marked simple point processes.

Definition 1.2.3 (Invariant set). *We say that $B \in \mathcal{B}(\mathcal{N}^\#)$ is an invariant set under the shifts $\{S_x\}$ if $S_x B = B$ for any $x \in \mathbb{R}^d$. We denote by \mathcal{I} the σ -algebra of such invariant sets.*

Definition 1.2.4 (Ergodic marked simple point process). *A marked simple point process μ on \mathbb{R}^d with marks in \mathcal{K} (or equivalently, its law \mathbb{P}) is ergodic or metrically transitive (with respect to the shifts $\{S_x\}$ for $x \in \mathbb{R}^d$) if, for all invariant sets $B \in \mathcal{B}(\mathcal{N}^\#)$ with respect to the shifts $\{S_x\}$, we have $\mathbb{P}(B) \in \{0, 1\}$.*

To state the ergodic theorem for stationary marked simple point process we need to define before a convex averaging sequence of sets: given a sequence $\{A_n\}$ of bounded Borel sets in \mathbb{R}^d , we say that $\{A_n\}$ is a *convex averaging sequence* if

- (i) each A_n is convex;
- (ii) $A_n \subset A_{n+1}$ for $n \in \mathbb{N}$;
- (iii) $\sup\{r \geq 0 \mid A_n \text{ contains a ball of radius } r\} \rightarrow \infty$ as $n \rightarrow \infty$.

We have the following results (see [1, Proposition 10.2.II(a)] and [1, Theorem 10.2.IV] respectively).

Theorem 1.2.5. *Let μ be a marked simple point process on \mathbb{R}^d with marks in \mathcal{K} . Suppose that μ is stationary. Then for all measurable functions f on $\mathcal{N}^\#$ with $\mathbb{E}[|f|] < \infty$ and for all convex averaging sequences $\{A_n\}$ of bounded Borel subsets of \mathbb{R}^d , we have \mathbb{P} -almost surely*

$$\frac{1}{l(A_n)} \int_{A_n} f(S_x \mu) dx \rightarrow \mathbb{E}[f \mid \mathcal{I}]$$

as $n \rightarrow \infty$, where $l(\cdot)$ is the Lebesgue measure on \mathbb{R}^d .

Note that if μ is also ergodic, then $\mathbb{E}[f \mid \mathcal{I}] = \mathbb{E}[f]$.

Theorem 1.2.6. *Let μ be a marked simple point process on \mathbb{R}^d with marks in \mathcal{K} and suppose that μ is stationary. Let $\{A_n\}$ be a convex averaging sequence of bounded Borel subsets of \mathbb{R}^d . Then as $n \rightarrow \infty$ we have \mathbb{P} -almost surely*

$$\frac{\mu(A_n \times \mathcal{K})}{l(A_n)} \rightarrow \mathbb{E}[\mu([0, 1]^d \times \mathcal{K}) \mid \mathcal{I}],$$

where $l(\cdot)$ is the Lebesgue measure in \mathbb{R}^d .

Note that if μ is also ergodic, then $\mathbb{E}[\mu([0, 1]^d \times \mathcal{K}) \mid \mathcal{I}] = \mathbb{E}[\mu([0, 1]^d \times \mathcal{K})] = M([0, 1]^d)$.

1.3 Campbell measure and Palm distribution

Let us consider a marked point process μ on \mathbb{R}^d with marks in \mathcal{K} and denote by \mathbb{P} and \mathbb{E} its law and the expectation associated with \mathbb{P} , respectively. It is possible to define a measure on $\mathbb{R}^d \times \mathcal{N}^\#$ by setting for $A \in \mathcal{B}(\mathbb{R}^d)$ and $U \in \mathcal{B}(\mathcal{N}^\#)$

$$C_{\mathbb{P}}(A \times U) = \mathbb{E}[\mu(A \times \mathcal{K})\mathbb{1}_U(\mu)] = \int_U \mathbb{P}(d\mu) \int_A \mu(dx \times \mathcal{K}).$$

The measure $C_{\mathbb{P}}$ is countably additive and extends uniquely to a σ -finite measure on $\mathcal{B}(\mathbb{R}^d) \otimes \mathcal{B}(\mathcal{N}^\#)$ (see [1, Section 12.1]), that we still denote by $C_{\mathbb{P}}$. Such a measure is called *Campbell measure* (see [1, Definition 12.1.I]).

Hence for any $\mathcal{B}(\mathbb{R}^d) \otimes \mathcal{B}(\mathcal{N}^\#)$ -measurable nonnegative function g we have the following formula (see [1, Lemma 12.1.II])

$$\begin{aligned} \mathbb{E} \left[\int_{\mathbb{R}^d} g(x, \mu) \mu(dx \times \mathcal{K}) \right] &= \int_{\mathcal{N}^\#} \mathbb{P}(d\mu) \int_{\mathbb{R}^d} g(x, \mu) \mu(dx \times \mathcal{K}) = \\ &= \int_{\mathbb{R}^d \times \mathcal{N}^\#} g(x, \mu) C_{\mathbb{P}}(dx \times d\mu). \end{aligned} \quad (1.4)$$

Note that $C_{\mathbb{P}}(A \times \mathcal{N}^\#) = M(A)$ for any $A \in \mathcal{B}(\mathbb{R}^d \times \mathcal{K})$ (see Definition 1.1.9). Hence for any $U \in \mathcal{B}(\mathcal{N}^\#)$ the measure $C_{\mathbb{P}}(\cdot \times U)$ is absolutely continuous with respect to the measure $M(\cdot)$. Hence we can define the Radon-Nikodym derivative as a $\mathcal{B}(\mathbb{R}^d)$ -measurable function $\mathcal{P}(x, U)$ such that for any $A \in \mathcal{B}(\mathbb{R}^d)$ it holds

$$\int_A \mathcal{P}(x, U) M(dx) = C_{\mathbb{P}}(A \times U). \quad (1.5)$$

$\mathcal{P}(x, U)$ is defined uniquely up to values on sets of zero M -measure. Furthermore the family $\{\mathcal{P}(x, U)\}$ can be chosen so that (see [1, Formulas (12.1.5a) and (12.1.5b), Sec. 12.1])

- (i) for any fixed $U \in \mathcal{B}(\mathcal{N}^\#)$, $\mathcal{P}(x, U)$ is a measurable function of x , M -integrable on bounded Borel subsets of \mathbb{R}^d ;
- (ii) for any fixed $x \in \mathbb{R}^d$, $\mathcal{P}(x, U)$ is a probability measure on $U \in \mathcal{B}(\mathcal{N}^\#)$.

For any $x \in \mathbb{R}^d$ the measure $\mathcal{P}(x, \cdot)$ is called *local Palm distribution* and a family of such measures that satisfies (i) and (ii) is defined a *Palm kernel* associated with μ (or its law \mathbb{P}).

By (1.5), it is possible to rewrite (1.4) in the following way (see [1, Proposition 12.1.IV])

$$\mathbb{E} \left[\int_{\mathbb{R}^d} g(x, \mu) \mu(dx \times \mathcal{K}) \right] = \int_{\mathbb{R}^d \times \mathcal{N}^\#} g(x, \mu) C_{\mathbb{P}}(dx \times d\mu) = \int_{\mathbb{R}^d} M(dx) \mathbb{E}^{(x)}[g(x, \mu)], \quad (1.6)$$

where

$$\mathbb{E}^{(x)}[g(x, \mu)] = \int_{\mathcal{N}^\#} g(x, \mu) \mathcal{P}(x, d\mu)$$

and g is a $\mathcal{B}(\mathbb{R}^d) \otimes \mathcal{B}(\mathcal{N}^\#)$ -measurable nonnegative function.

The following result gives a characterization of the Palm kernel associated to the law \mathbb{P} in terms of the so called *Laplace functional*. Given a nonnegative $\mathcal{B}(\mathbb{R}^d)$ -measurable function f with bounded support, we define, respectively, the Laplace functionals associated to the law \mathbb{P} and its local Palm distribution $\mathcal{P}(x, \cdot)$ as

$$L[f] = \int_{\mathcal{N}^\#} \exp\left(-\int_{\mathbb{R}^d} f(y)\mu(dy \times \mathcal{K})\right) \mathbb{P}(d\mu), \quad (1.7)$$

$$L[f; x] = \int_{\mathcal{N}^\#} \exp\left(-\int_{\mathbb{R}^d} f(y)\mu(dy \times \mathcal{K})\right) \mathcal{P}(x, d\mu), \quad \text{for } x \in \mathbb{R}^d. \quad (1.8)$$

We have the following result (see [1, Proposition 12.1.V]).

Proposition 1.3.1. *Let μ be a marked simple point process on \mathbb{R}^d with marks in \mathcal{K} and denote by \mathbb{P} and M its law and its intensity measure, respectively. Given two nonnegative $\mathcal{B}(\mathbb{R}^d)$ -measurable functions f, g with bounded support, we have*

$$\lim_{\varepsilon \downarrow 0} \frac{L[f] - L[f + \varepsilon g]}{\varepsilon} = \int_{\mathbb{R}^d} g(x)L[f; x]M(dx), \quad (1.9)$$

where $L[f]$ and $L[f; x]$ are defined as in (1.7) and (1.8), respectively.

Conversely, if a family $\{L[f; x]\}$ satisfies (1.9) for all nonnegative and $\mathcal{B}(\mathbb{R}^d)$ -measurable functions f, g with bounded support and for some point process μ with Laplace functional $L[\cdot]$ and intensity measure $M(\cdot)$, then the functionals $\{L[f; x]\}$ coincide M -a.e. with the Laplace functionals of the Palm kernel associated with μ .

This characterization will be useful to derive the explicit form of the Palm kernel for marked Poisson point processes (see Section 1.4).

1.3.1 The stationary case

We define $\mathcal{N}_0^\# := \{\mu \in \mathcal{N}^\# \mid \mu(\{0\}) = 1\}$. Suppose that μ is stationary and that $M([0, 1]^d) = \lambda \in (0, +\infty)$ (see Proposition 1.2.2). In this case, the local Palm distributions become translated versions of a single basic distribution \mathbb{P}_0 (see [1, Formula (12.1.7)]) and hence, using (1.6) and Proposition 1.2.2, it is possible to prove the following identity (see [1, Formula (12.2.4), Theorem 12.2.II and Section 12.3]):

$$\begin{aligned} \mathbb{E} \left[\int_{\mathbb{R}^d} g(x, S_x \mu) \mu(dx \times \mathcal{K}) \right] &= \int_{\mathcal{N}^\#} \mathbb{P}(d\mu) \int_{\mathbb{R}^d} g(x, S_x \mu) \mu(dx \times \mathcal{K}) = \\ &= \lambda \int_{\mathcal{N}_0^\#} \mathbb{P}_0(d\mu) \int_{\mathbb{R}^d} g(x, \mu) dx \end{aligned} \quad (1.10)$$

for any $\mathcal{B}(\mathbb{R}^d) \otimes \mathcal{B}(\mathcal{N}^\#)$ -measurable nonnegative function g . The above probability measure \mathbb{P}_0 is the so called *Palm distribution* associated with the stationary marked simple point process μ or with its law \mathbb{P} . The identity (1.10) is known as *Campbell's formula* and allows to characterize the probability measure \mathbb{P}_0 in the following way

$$\mathbb{P}_0(A) = \frac{1}{\lambda} \mathbb{E} \left[\int_{\mathbb{R}^d} \mathbb{1}_A(S_x \mu) \mu(dx \times \mathcal{K}) \right], \quad (1.11)$$

for any $A \in \mathcal{B}(\mathcal{N}_0^\#)$. We point out that \mathbb{P}_0 has support inside $\mathcal{N}_0^\#$.

The introduction of the Palm measure allows us to state the following results (see [1, Proposition 12.2.VI] and [1, Theorem 12.3.V]).

1.4 Poisson point process

Proposition 1.3.2. *Let μ be a stationary ergodic marked simple point process on \mathbb{R}^d with marks in \mathcal{K} and suppose that $M([0, 1]^d) = \lambda \in (0, +\infty)$. Denote by \mathbb{P} and \mathbb{P}_0 its law and the associated Palm distribution, respectively. Then for any $\mathcal{B}(\mathcal{N}^\#)$ -measurable nonnegative function g on $\mathcal{N}^\#$ and for any convex averaging sequence $\{A_n\}$, we have \mathbb{P} -almost surely*

$$\frac{1}{l(A_n)} \int_{A_n} g(S_x \mu) \mu(dx \times \mathcal{K}) \rightarrow \lambda \int_{\mathcal{N}_0^\#} g(\mu) \mathbb{P}_0(d\mu) \quad \text{as } n \rightarrow \infty.$$

Proposition 1.3.3. *Let μ be a stationary marked simple point process on \mathbb{R}^d with marks in \mathcal{K} and suppose that $M([0, 1]^d) = \lambda \in (0, +\infty)$. Denote by \mathbb{P} and \mathbb{P}_0 its law and the associated Palm measure. Let $\{A_n\}$ be a sequence of bounded Borel subsets of \mathbb{R}^d with positive Lebesgue measure such that $A_n \subset A_{n-1}$ for all n and*

$$\text{diam}(A_n) := \max\{|x - y| : x, y \in A_n\} \rightarrow 0 \quad \text{as } n \rightarrow \infty.$$

Then we have as $n \rightarrow \infty$

$$\frac{\mathbb{P}(\mu(A_n) > 0)}{l(A_n)} \rightarrow \lambda.$$

In particular, if $\{A_n\}$ are balls in \mathbb{R}^d centered at the origin, then for any bounded continuous nonnegative $\mathcal{B}(\mathcal{N}^\#)$ -measurable function f on $\mathcal{N}^\#$ we have

$$\mathbb{E}[f(\mu) \mid \mu(A_n) > 0] \rightarrow \int_{\mathcal{N}_0^\#} \mathbb{P}_0(d\mu) f(\mu).$$

1.4 Poisson point process

In this section we will introduce the Poisson point process as a particular type of simple point process. As discussed in Remark 1.1.7, simple point processes can be seen as marked simple point processes in which the space of the marks contains only one element. Hence all the definitions that have been given in the previous sections about marked simple point processes can be immediately transferred to simple point processes.

Definition 1.4.1 (Poisson point process). *Let Λ be a boundedly finite measure on \mathbb{R}^d . We say that a simple point process μ is a Poisson point process with intensity Λ if its law \mathbb{P} satisfies the following properties:*

- for every $B \in \mathcal{B}(\mathbb{R}^d)$ we have that $\mu(B)$ is a Poisson random variable with mean $\Lambda(B)$, that is

$$\mathbb{P}(\mu(B) = k) = e^{-\Lambda(B)} \frac{\Lambda(B)^k}{k!}, \quad \text{for } k \in \mathbb{N}, \quad (1.12)$$

with the convention that, when $\Lambda(B) = \infty$, (1.12) reads $\mathbb{P}(\mu(B) = k) = 0$ for any $k \in \mathbb{N}$;

- if B_1, \dots, B_m are disjoint elements of $\mathcal{B}(\mathbb{R}^d)$, then $\mu(B_1), \dots, \mu(B_m)$ are independent random variables.

The intensity measure of μ (see Definition 1.1.9) coincide with the measure Λ , since for any $A \in \mathcal{B}(\mathbb{R}^d)$ we have $M(A) = \mathbb{E}[\mu(A)] = \Lambda(A)$, where \mathbb{E} is the expectation associated to the law \mathbb{P} . Hence we will refer to Λ as the intensity measure of the Poisson point process μ .

In particular we say that μ is homogeneous if $\Lambda(\cdot) = \lambda \cdot l(\cdot)$ for some $\lambda \in [0, +\infty)$, where $l(\cdot)$ is the Lebesgue measure on \mathbb{R}^d (otherwise we say that μ is non-homogeneous). In this case we define λ as the density of the homogeneous Poisson point process. Moreover, if μ is homogeneous, λ coincide with the expected number of points in the d -dimensional cube $[0, 1]^d$, that is $\mathbb{E}[\mu([0, 1]^d)] = \lambda$.

Note that for any measure Λ on \mathbb{R}^d there exists at most one Poisson point process on \mathbb{R}^d with intensity measure Λ up to equality in distribution. Moreover, if μ_1 and μ_2 are two independent Poisson point process on \mathbb{R}^d with intensity measures Λ_1 and Λ_2 , their superposition $\mu_1 + \mu_2$ is again a Poisson point process on \mathbb{R}^d with intensity measure $\Lambda_1 + \Lambda_2$ (see [4, Section 1.3]).

Definition 1.4.2 (Thinning of a Poisson point process). *Let $g : \mathbb{R}^d \rightarrow [0, 1]$ be a measurable function and let μ be a homogeneous Poisson point process on \mathbb{R}^d with density λ . We define a new point process $\tilde{\mu}$ on \mathbb{R}^d in the following way: given a realization μ of μ and a point $x \in \mathbb{R}^d$ for which $\mu(\{x\}) = 1$, we take the point away with probability $1 - g(x)$ and leave it where it is with probability $g(x)$, independently of all other points of the Poisson point process. This operation is done independently also when changing μ . We say that $\tilde{\mu}$ is a thinning of μ .*

One can prove the point process $\tilde{\mu}$ described in Definition 1.4.2 is a non-homogeneous Poisson point process on \mathbb{R}^d with intensity measure Λ that satisfies the identity $\Lambda(A) = \lambda \int_A g(x) dx$ for any $A \in \mathcal{B}(\mathbb{R}^d)$ (see [4, Proposition 1.3]). In particular, if $g(x) = c \in [0, 1]$ is a constant function, then μ is a homogeneous Poisson point process on \mathbb{R}^d with density λc .

Note that, since the Lebesgue measure $l(\cdot)$ is invariant under translations on \mathbb{R}^d , by (1.12) we have that the homogeneous Poisson point process is stationary with respect to translations on \mathbb{R}^d (see Definition 1.2.1). Moreover, one has the following result (see [4, Proposition 2.6]).

Proposition 1.4.3. *The homogeneous Poisson point process on \mathbb{R}^d is ergodic (see Definition 1.2.4).*

Now let us consider the Laplace functional (see (1.7)) for the Poisson point process on \mathbb{R}^d with intensity measure Λ . We have that, for all nonnegative $\mathcal{B}(\mathbb{R}^d)$ -measurable function f with bounded support, $L[f]$ is of the form (see [3, Theorem 3.9])

$$L[f] = \exp \left(- \int_{\mathbb{R}^d} (1 - e^{-f(x)}) \Lambda(dx) \right).$$

By Proposition 1.3.1 it is possible to prove that for all the $\mathcal{B}(\mathbb{R}^d)$ -measurable function f with bounded support and for all $x \in \mathbb{R}^d$ the Laplace functional $L[f; x]$ satisfies the identity

$$L[f; x] = L[f] L_{\delta_x}[f],$$

Bibliography

where $L_{\delta_x}[f]$ is the Laplace functional of a point process μ whose law is concentrated on the counting measure $\delta_x \in \mathcal{N}^\#$ defined by the relation $\delta_x(\{y\}) = \mathbb{1}_{\{x=y\}}(y)$ for any $y \in \mathbb{R}^d$ (see [1, Example 12.1(b)]). Hence the local Palm distribution of the Poisson point process $\mathcal{P}(x, \cdot)$ coincide with the distribution of the Poisson point process on \mathbb{R}^d with the exception that a point at x is added in all realizations of the process (see [1, Formula (12.1.12)]). Moreover one can prove that the Poisson point process is the unique point process whose Palm kernel is of that form (see [1, Proposition 12.1.VI]).

In particular, since the homogeneous Poisson point process is stationary, we can use the Campbell's formula (1.10) in which the law \mathbb{P}_0 coincide with the law of a homogeneous Poisson point process on \mathbb{R}^d with the same density, but with the exception that a point at 0 is added in all realizations of the process.

In Chapter 4 and Chapter 5 we will focus on the ν -randomization of a homogeneous Poisson point process, where ν will be a given probability measure. We describe below this concept.

Definition 1.4.4 (ν -randomization of a homogeneous Poisson point process). *Given a Polish space \mathcal{K} , a probability measure ν on $(\mathcal{K}, \mathcal{B}(\mathcal{K}))$ and a positive constant $\lambda > 0$, the ν -randomization of the homogeneous Poisson point process with density λ is the marked simple point process μ obtained as follows: calling $\{x_i\}$ a realization of a homogeneous Poisson point process with density λ , a realization μ of μ is obtained by marking each point x_i with a random variable k_i such that $\{k_i\}$ are i.i.d. random variables with law ν . This operation is done independently also when changing $\{x_i\}$.*

Bibliography

- [1] D.J. Daley, D. Vere–Jones. *An Introduction to the Theory of Point Processes*. New York, Springer Verlag (1988).
- [2] A.S. Kechris. *Classical Descriptive Set Theory*. New York, Springer Verlag, (1995).
- [3] G. Last, M.D. Penrose. *Lectures on the Poisson Process*. Cambridge University Press (2017).
- [4] R. Meester, R. Roy. *Continuum percolation*. Cambridge Tracts in Mathematics **119**. First edition, Cambridge University Press, Cambridge (1996).

Chapter 2

Discrete and continuum percolation

Many phenomena in physics, biology and chemistry can be modelled by spatial random processes where the randomness concerns the geometry of the space instead of the random motion of a body in a deterministic environment. Basic models of random geometry are given by discrete and continuum percolation models.

In this chapter we give an overview of some important properties about the most famous models in this two groups: the bond/site percolation on \mathbb{Z}^d for the discrete field, the random connection model and the Boolean model for the continuous one. The main references in this field are [5] and [8].

2.1 Discrete percolation

Let us define $\mathcal{G} = (\mathcal{V}, \mathcal{E})$ as the graph whose vertex set is given by $\mathcal{V} := \mathbb{Z}^d$ and edge set $\mathcal{E} := \{\{x, y\} : x, y \in \mathbb{Z}^d, \|x - y\|_1 = 1\}$, where for any $v = (v_1, \dots, v_d) \in \mathbb{R}^d$

$$\|v\|_1 = \sum_{i=1}^d |v_i|.$$

Definition 2.1.1 (Configuration). *We define a configuration on \mathcal{E} as an element $\omega := \{\omega_e\}_{e \in \mathcal{E}}$ of the space $\Omega := \{0, 1\}^{\mathcal{E}}$.*

Fixed a parameter $p \in [0, 1]$, in the *Bernoulli bond percolation* each edge of \mathcal{G} is said to be open with probability p and closed with probability $1 - p$, independently of the other edges.

Hence, if we associate to each edge $e \in \mathcal{E}$ a random variable ω_e such that

$$\omega_e = \begin{cases} 1, & \text{if } e \text{ is open,} \\ 0, & \text{if } e \text{ is closed,} \end{cases}$$

we have that $\{\omega_e\}_{e \in \mathcal{E}}$ are i.i.d. Bernoulli random variables (equivalently, ω is a Bernoulli random field) of parameter p . Moreover we have that $\omega := \{\omega_e\}_{e \in \mathcal{E}}$ is a random variable whose realizations are elements $\omega \in \Omega$. For this reason we will refer to ω as a *random configuration* and we denote, respectively, by \mathbb{P}_p and \mathbb{E}_p its law and the expectation associated to \mathbb{P}_p , that obviously depend on p .

Warning 2.1.1. *As in the previous chapter, we use bold letters as ω for random objects, while we will use non-bold letters as ω for their realizations.*

Definition 2.1.2 (Open path). *Fixed a configuration $\omega \in \Omega$, an open path π in the graph \mathcal{G} is given by an ordered set of vertexes x_1, \dots, x_k of the graph \mathcal{G} such that $\{x_i, x_{i+1}\}$ is an open edge of \mathcal{G} for $i = 1, \dots, k - 1$. We will write $\pi := (x_1, \dots, x_k)$ when we want to specify the vertexes in the path and we will refer to x_1 and x_k as extremal vertexes of the path π .*

Definition 2.1.3. *Given a configuration $\omega \in \Omega$ and two points $x, y \in \mathcal{V}$, we say that x is connected to y (in the configuration ω), and we write $x \leftrightarrow y$, if there exists an open path π (in the configuration ω) whose extremal vertexes are x and y . Given two subsets A and B of \mathcal{V} , we say that A is connected to B (in the configuration ω), and we write $A \leftrightarrow B$, if there exists $x \in A$ and $y \in B$ such that $x \leftrightarrow y$ (in the configuration ω). If $A = \{x\}$ with $x \in \mathcal{V}$, we write $x \leftrightarrow B$ instead of $\{x\} \leftrightarrow B$ to simplify the notation.*

Definition 2.1.4 (Open cluster). *Fixed a configuration $\omega \in \Omega$ and a vertex $x \in \mathcal{V}$, we denote by $C(\omega, x)$ the open cluster of x in the configuration ω , i.e. the set of all the vertexes of \mathcal{V} that are connected to x in the configuration ω . When x is the origin, to simplify the notation we drop the dependence on x and we simply write $C(\omega)$ instead of $C(\omega, 0)$. Moreover we write \mathbf{C} and $\mathbf{C}(x)$ for the random variables $C(\omega)$ and $C(\omega, x)$, respectively.*

We adopt the convention that for any vertex $x \in \mathcal{V}$, $x \in C(\omega, x)$ for any configuration ω .

In the following, given a subset A of \mathcal{V} , we denote by $|A|$ its cardinality. Moreover, fixed an integer $n > 0$, we define the sets

$$\Lambda_n = \{y \in \mathcal{V} : \|y\|_\infty \leq n\}, \quad \partial\Lambda_n := \{y \in \mathcal{V} : \|y\|_\infty = n\}.$$

We are interested in studying the cardinality of $\mathbf{C}(x)$ for $x \in \mathcal{V}$. Note that by translation invariance of the lattice \mathcal{G} , we have that \mathbf{C} and $\mathbf{C}(x)$ have the same law for all $x \in \mathcal{V}$ and hence it is enough to study $|\mathbf{C}|$.

We define the *percolation probability* as

$$\theta(p) = \mathbb{P}_p(|\mathbf{C}| = \infty).$$

Obviously $\theta(0) = 0$, $\theta(1) = 1$ and, by a coupling argument (see [5, Section 1.3]), one can show that θ is non-decreasing. Hence, by defining the *critical probability* as

$$p_c(d) = \sup\{p : \theta(p) = 0\},$$

we have that

$$\begin{cases} \theta(p) > 0; & \text{if } p > p_c, \\ \theta(p) = 0; & \text{if } p < p_c, \end{cases}$$

that is we have a *phase transition*. We refer to the regimes $p > p_c$, $p < p_c$ and $p = p_c$ as the supercritical, the subcritical and the critical phases, respectively.

2.1 Discrete percolation

It is easy to show that $p_c(1) = 1$ (see [5, Section 1.4]) and $p_c(d+1) < p_c(d)$ (see [5, Section 1.4 and Section 3.3]), that implies $p_c(d) \in [0, 1)$ if $d \geq 2$ (see [5, Theorem 1.10]). In dimension $d = 2$ we have that the critical probability equals $\frac{1}{2}$ (see [5, Theorem 11.11]).

A natural question concerns the value of $\theta(p)$ when $p = p_c(d)$. We know that θ is an infinitely differentiable function of p on $(p_c, 1]$ (see [5, Theorem 8.92]), but we are still not able to say that in general θ is continuous at $p_c(d)$ for any d . If $d = 2$, we have that $\theta(p_c(2)) = \theta(1/2) = 0$ (see [5, Theorem 11.12]). For $d \geq 19$ Hara and Slade proved that $\theta(p_c(d)) = 0$ (see [7]) and a more delicate use of their techniques has allowed an extension of their result for $d \geq 11$ (see [3]). The identity $\theta(p_c(d)) = 0$ for $d \geq 3$ is one of the major conjectures in this field.

Consider now the function

$$\psi(p) := \mathbb{P}_p(\text{there exists an infinite open cluster}).$$

By the Kolmogorov's zero-one law (see [6, Theorem 15 in Section 7.3]), one can show that (see [5, Theorem 1.11])

$$\psi(p) = \begin{cases} 0, & \text{if } \theta(p) = 0, \\ 1, & \text{if } \theta(p) > 0. \end{cases} \quad (2.1)$$

Note that when we compute $\psi(p)$ we look for an open cluster of a general node of \mathcal{V} , while $\theta(p)$ looks only at the cluster of the origin.

Before looking with more details at the supercritical and subcritical phases, we want to introduce the model of the *Bernoulli site percolation* on \mathcal{G} . In this case, fixed $p \in [0, 1]$, a vertex $v \in \mathcal{V}$ is said to be occupied with probability p and unoccupied with probability $1 - p$, independently of the other vertexes. So the set of the configurations will be given by $\Omega := \{0, 1\}^{\mathcal{V}}$ and we denote by \mathbb{P}_p the law of the random configuration ω . By defining an open path as a sequence of occupied vertexes x_1, \dots, x_k such that $|x_i - x_{i-1}| = 1$ for $i = 1, \dots, k$, Definition 2.1.3 and Definition 2.1.4 can be transferred directly into this setting. Moreover we can similarly define $\theta(p)$ and $p_c(d)$. To state the relation between the site and the bond percolation we will denote by $p_c^{\text{site}}(d)$ and $p_c^{\text{bond}}(d)$ the critical probabilities for site and bond percolation, respectively. One can prove that (see [5, Theorem 1.33 and Theorem 3.28])

$$\frac{1}{2d-1} \leq p_c^{\text{bond}}(d) < p_c^{\text{site}}(d) \leq 1 - (1 - p_c^{\text{bond}}(d))^{2d}.$$

Hence, studying one model, one can deduce many properties of the other one.

In the rest of the section we will focus only on the Bernoulli bond percolation and we will continue to denote by $p_c(d)$ its critical probability.

2.1.1 The supercritical phase

In the supercritical regime by (2.1) we know that \mathbb{P}_p -almost surely there exists an infinite open cluster. In particular it is possible to show that such a cluster is unique \mathbb{P}_p -almost surely (see [5, Theorem 8.1]) and its ‘‘surface’’ has the same order as its volume. More precisely, denoting by \mathbf{I} the infinite cluster, \mathbf{I}_e the set of the open

edges with both endpoints in \mathbf{I} and by $\Delta\mathbf{I}$ the set of the closed edges that have at least one endpoint in \mathbf{I} , if $p > p_c$ we have \mathbb{P}_p -almost surely (see [5, Theorem 8.99])

$$\frac{|\Delta\mathbf{I} \cap \Lambda_n|}{|\mathbf{I}_e \cap \Lambda_n|} \rightarrow \frac{1-p}{p} \quad \text{as } n \rightarrow \infty.$$

We can also focus on the properties of the finite clusters in the supercritical regime. Indeed when $p > p_c$ one has (see [5, Theorem 8.18])

$$\mathbb{P}_p(0 \leftrightarrow \partial\Lambda_n, |\mathbf{C}| < \infty) \sim e^{-\sigma(p)n} \quad \text{as } n \rightarrow \infty$$

and (see [5, Theorem 8.61 and 8.65])

$$\exp\left(-\gamma(p)n^{(d-1)/d}\right) \leq \mathbb{P}_p(|\mathbf{C}| = n) \leq \exp\left(-\eta(p)n^{(d-1)/d}\right) \quad \text{for all } n,$$

where $\sigma(p), \gamma(p), \eta(p)$ are positive constants depending on p .

Another interesting problem that has been analyzed in the supercritical regime concerns the number of edge-disjoint open left-right crossings of a fixed box. More precisely, we define an open left-right crossing of the box Λ_n (with respect to the first direction) in the graph \mathcal{G} as a path $\pi = (x^{(1)}, \dots, x^{(k)})$ in \mathcal{G} such that

- $x^{(i)} \in \Lambda_n$ for $i = 1, \dots, k$;
- the edge $\{x^{(i)}, x^{(i+1)}\}$ is open;
- $x_1^{(1)} = -n$ and $x_1^{(k)} = n$.

Denoting by M_n the maximal number of edge-disjoint open left-right crossing of Λ_n , we have the following result (see [5, Theorem 7.68] in the case $d \geq 3$ and [5, Theorem 11.22] when $d = 2$).

Theorem 2.1.5. *If $p > p_c(d)$, there exist strictly positive constants $\beta(p)$ and $\gamma(p)$, depending on p , such that*

$$\mathbb{P}_p(M_n \geq \beta(p)n^{d-1}) \geq 1 - e^{-\gamma(p)n^{d-1}}, \quad \text{for } n \geq 1.$$

2.1.2 The subcritical phase

In the subcritical phase by (2.1) we know that there does not exist an infinite open cluster \mathbb{P}_p -almost surely. Hence we analyze the finite clusters wondering about their size. Indeed Menshikov's theorem holds (see [5, Theorem 5.4]): if $p < p_c$, then there exists a positive constant $c(p)$ depending on p such that

$$\mathbb{P}_p(0 \leftrightarrow \partial\Lambda_n) < e^{-c(p)n} \quad \text{for } n \geq 1.$$

This result is known also as *sharpness of the phase transition* and says in particular that the size of the biggest cluster in a box of side-length n is typically of order $\log n$ if $p < p_c$. Moreover it implies that in the subcritical regime $\mathbb{E}_p[|\mathbf{C}|] < \infty$ (see [5, Theorem 5.2]) and in particular (see [5, Theorem 6.75]) there exists a positive constant $\alpha(p)$ depending on p such that

$$\mathbb{P}_p(|\mathbf{C}| \geq n) \leq e^{-\alpha(p)n} \quad \text{for } n \geq 1.$$

2.1 Discrete percolation

2.1.3 FKG inequality and Russo's formula

In this paragraph we introduce two key elements in this field: the FKG inequality and Russo's formula.

Let \mathcal{F} be the σ -algebra of subsets of Ω generated by the finite-dimensional cylinders (cf. Definition 2.1.1).

Definition 2.1.6. *Given two configurations $\omega_1, \omega_2 \in \Omega$, we say that $\omega_1 \preceq \omega_2$ if $\omega_1(e) \leq \omega_2(e)$ for any $e \in \mathcal{E}$. A \mathcal{F} -measurable function $f : \Omega \rightarrow \mathbb{R}$ is said to be increasing (respectively decreasing) if $f(\omega_1) \leq f(\omega_2)$ (respectively $f(\omega_1) \geq f(\omega_2)$) whenever $\omega_1 \preceq \omega_2$. An event $A \in \mathcal{F}$ is said to be increasing (respectively decreasing) if its indicator function is increasing (respectively decreasing).*

The following proposition gives a fundamental inequality that allows to give a bound to the probability of an intersection of two events in terms of the probability of the single events even if they are not independent (see [5, Theorem 2.4]).

Proposition 2.1.7 (FKG inequality). *Let $f_1 : \Omega \rightarrow \mathbb{R}$ and $f_2 : \Omega \rightarrow \mathbb{R}$ be both increasing or both decreasing \mathcal{F} -measurable functions with finite second moment. Then*

$$\mathbb{E}_p[f_1 f_2] \geq \mathbb{E}_p[f_1] \mathbb{E}_p[f_2].$$

Consequently, if $A, B \in \mathcal{F}$ are both increasing or both decreasing events, we have

$$\mathbb{P}_p(A \cap B) \geq \mathbb{P}_p(A) \mathbb{P}_p(B).$$

Remark 2.1.8. *Note that if A is an increasing event, then its complement is a decreasing event. Hence if A and B are an increasing and a decreasing event, respectively, from the FKG inequality we have*

$$\mathbb{P}_p(A \cap B) \leq \mathbb{P}_p(A) \mathbb{P}_p(B).$$

Consider now an increasing event $A \in \mathcal{F}$ that depends only on finitely many edges and let us analyze the application $p \mapsto \mathbb{P}_p(A)$. Russo's formula (see [5, Proposition 2.25]), also known as Russo-Margulis formula, gives an estimate for the rate of change of this function. To write this identity, we need to define the pivotal edges for A .

Definition 2.1.9. *Given a configuration ω and an edge $e \in \mathcal{E}$, we define $\omega^e \in \Omega$ as the configuration that coincide with ω in all the edges $f \neq e$ and $\omega^e(e) = 1 - \omega(e)$. The edge e is said to be pivotal for the event A if $\mathbb{1}_A(\omega) \neq \mathbb{1}_A(\omega^e)$. In words, an edge e is pivotal for A if the occurrence or non-occurrence of A depends crucially on the opening state of e .*

Proposition 2.1.10 (Russo's formula). *Let $A \in \mathcal{F}$ be an increasing event that depends only on finitely many edges. Then*

$$\frac{d}{dp} \mathbb{P}_p(A) = \mathbb{E}_p[N(A)] = \sum_{e \in \mathcal{E}} \mathbb{P}_p(e \text{ is pivotal for } A),$$

where $N(A)$ is the number of pivotal edges for the event A .

2.2 Continuum percolation

In continuum percolation models the vertexes of the graph under investigation are given by some simple point process and an edge is inserted in the graph if some relation is satisfied. Such relation could depend on some quantities defined in the model such as the distance between the endpoints of the edge that we are analyzing or some marks associated with the edges or with the vertexes. We will describe some properties of two fundamental models in continuum percolation: the random connection model and the Boolean model.

2.2.1 The random connection model

Let us consider a stationary simple point process ξ on \mathbb{R}^d with $d \geq 2$ and let us associate with each pair $\{x, y\}$ of points of ξ a uniform random variable $U_{x,y}$ on $[0, 1]$, independently of the other pairs of points of ξ . Let $g : [0, +\infty) \rightarrow [0, 1]$ be a non-increasing function. Given two points x, y of ξ we say that $\{x, y\}$ is an edge if $U_{x,y} \leq g(|x - y|)$. For this reason the function g is usually called *connection function*.

Let us denote by \mathcal{G} the resulting random graph with vertex set ξ and edges as above. A path π in \mathcal{G} is given by an ordered set of points x_1, \dots, x_k in ξ such that $U_{x_i, x_{i+1}} \leq g(|x_{i+1} - x_i|)$ for $i = 1, \dots, k - 1$. In this case we say that x_1 is connected to x_k and we write $x_1 \leftrightarrow x_k$. Moreover we write $\pi = (x_1, \dots, x_k)$ and we refer to x_1 and x_k as extremal vertexes of π .

Suppose now that the origin is a point of ξ and define $S_n := \{y \in \mathbb{R}^d : \|y\|_\infty = n\}$. We say that $0 \leftrightarrow S_n$ if 0 is connected to a point y of ξ such that $\|y\|_\infty \geq n$. Moreover we write $0 \leftrightarrow \infty$ if for all $n > 0$ we have $0 \leftrightarrow S_n$. Finally we define the cluster of the point x of ξ as the set $\mathbf{C}(x)$ of the points of ξ that are connected to x .

The rigorous construction of such a process is described in [8, Section 1.5].

One can prove that if ξ is also ergodic, the number of infinite clusters is constant almost surely (see [8, Theorem 2.1]). To establish such a value we need some additional hypothesis on the point process and on the function g .

From now on we assume that ξ is a simple point process on \mathbb{R}^d sampled according to the Palm distribution associated to the homogeneous Poisson point process on \mathbb{R}^d with density λ . Denote by $\mathbb{P}_{0,\lambda}$ the law of the resulting graph \mathcal{G} and by \mathbb{P}_λ the law of \mathcal{G} when ξ is sampled as a homogeneous Poisson point process.

We define the *percolation probability* as

$$\theta_g(\lambda) = \mathbb{P}_{0,\lambda}(|\mathbf{C}(0)| = \infty)$$

and the *critical density* as

$$\lambda_c = \lambda_c(g) = \inf\{\lambda \geq 0 : \theta_g(\lambda) > 0\}.$$

As observed in [8, Theorem 6.1, Sec. 6.1], the model has a non-trivial phase transition, that is $\lambda_c \in (0, +\infty)$, if and only if

$$0 < \int_0^\infty r^{d-1} g(r) dr < \infty.$$

If such hypothesis is satisfied, one can prove that in the supercritical regime there exists a unique unbounded cluster \mathbb{P}_λ -almost surely (see [8, Theorem 6.3, Sec. 6.4]).

2.2 Continuum percolation

Moreover, as we will explain in details in the Chapter 4, it is possible to show that the phase transition is sharp under the following additional conditions on the function g :

- g is positive on a subset of positive Lebesgue measure;
- there exists a finite family of points $0 < r_1 < r_2 < \dots < r_{m-1} < r_m$ such that $g(r) = 0$ for $r \geq r_m$ and g is uniformly continuous on (r_i, r_{i+1}) for all $i = 0, \dots, m-1$, where $r_0 := 0$.

Indeed if such hypotheses are satisfied, one has that (see [2, Theorem 1] or equivalently Chapter 4)

- for any $\lambda > \lambda_c$ there exists $c(\lambda) > 0$ such that

$$\mathbb{P}_{0,\lambda}(0 \leftrightarrow S_n) \leq e^{-c(\lambda)n} \quad \text{for all } n \in \mathbb{N};$$

- there exists $C > 0$ such that

$$\mathbb{P}_{0,\lambda}(0 \leftrightarrow \infty) \geq C(\lambda - \lambda_c) \quad \text{for any } \lambda > \lambda_c.$$

2.2.2 The Boolean model

Let us consider a stationary simple point process ξ on \mathbb{R}^d with $d \geq 2$ (we will say that the model is *driven* by ξ). To each point x of ξ we associate a nonnegative random variable \mathbf{r}_x , independently of the other points. We suppose that such variables are identically distributed. Given two points x, y of ξ , we say that $\{x, y\}$ is an edge if $|x - y| \leq \mathbf{r}_x + \mathbf{r}_y$.

Let us denote by \mathcal{G} the resulting random graph with vertex set ξ and edges as above. A path π in \mathcal{G} is given by an ordered set of points x_1, \dots, x_k in ξ such that $|x_{i+1} - x_i| \leq \mathbf{r}_{x_{i+1}} + \mathbf{r}_{x_i}$ for $i = 1, \dots, k-1$. In this case we say that x_1 is connected to x_k and we write $x_1 \leftrightarrow x_k$. Moreover we write $\pi = (x_1, \dots, x_k)$ and we refer to x_1 and x_k as extremal vertexes of π .

Suppose now that the origin is a point of ξ and define $S_n := \{y \in \mathbb{R}^d : \|y\|_\infty = n\}$. We say that $0 \leftrightarrow S_n$ if 0 is connected to a point y of ξ such that $\|y\|_\infty \geq n$. Moreover we write $0 \leftrightarrow \infty$ if for all $n > 0$ we have $0 \leftrightarrow S_n$. Finally we define the cluster of the point x of ξ as the set $\mathbf{C}(x)$ of the points of ξ that are connected to x .

The rigorous construction of such a process is described in [8, Section 1.4].

It is possible to prove that if the point process ξ is also ergodic, then the number of infinite clusters is constant almost surely (see [8, Theorem 2.1, Sec. 2.1]).

From now on we suppose that ξ is a simple point process on \mathbb{R}^d sampled according to the Palm distribution associated to the homogeneous Poisson point process on \mathbb{R}^d with density λ and we write (ξ, ν, λ) for the Boolean model driven by ξ where the random variable \mathbf{r}_x associated to a point x of ξ has law ν . Let us denote by $\mathbb{P}_{0,\lambda}$ the law of the resulting graph \mathcal{G} and by \mathbb{P}_λ the law of \mathcal{G} when ξ is sampled as a homogeneous Poisson point process.

We define the *percolation probability* as

$$\theta_\nu(\lambda) = \mathbb{P}_{0,\lambda}(|\mathbf{C}(0)| = \infty)$$

and the *critical density* as

$$\lambda_c = \lambda_c(\nu) = \inf\{\lambda \geq 0 : \theta_\nu(\lambda) > 0\}.$$

Note that a necessary condition to have a non-trivial value for λ_c is that

$$\int_0^{+\infty} r^d \nu(dr) < \infty. \quad (2.2)$$

Indeed if this condition is not satisfied, one can prove that the whole space \mathbb{R}^d is covered by balls almost surely (see [8, Proposition 3.1, Sec. 3.1]). Actually one can prove that condition (2.2) is also sufficient to have $\lambda_c(\nu) \in (0, +\infty)$ (see [4, Theorem 2.1]).

If we assume some additional hypothesis on the distribution ν , it is possible to show that the phase transition is sharp. More precisely, we have the following result (see [1, Theorem 1 and Theorem 2]):

Theorem 2.2.1. *If*

$$\int_0^{+\infty} r^{5d-3} \nu(dr) < \infty, \quad (2.3)$$

then we have $\theta_\nu(\lambda) \geq c(\lambda - \lambda_c)$, for some constant $c > 0$ whenever $\lambda \geq \lambda_c$.

Moreover if (2.3) holds and there exists a constant $k > 0$ such that

$$\int_s^{+\infty} \nu(dr) \leq e^{-ks} \quad \text{for every } s \geq 1,$$

then we have that for any $\lambda < \lambda_c$ there exists $c_\lambda > 0$ such that for every $n \geq 1$

$$\mathbb{P}_{0,\lambda}(0 \leftrightarrow S_n) \leq e^{-c_\lambda n}.$$

Using the ergodicity of the Poisson point process, one can prove that in the supercritical case, that is $\lambda > \lambda_c$, the infinite cluster is unique (see [8, Theorem 3.6]). Moreover the function $\lambda \mapsto \theta_\nu(\lambda)$ is continuous for any $\lambda \neq \lambda_c(\nu)$ (see [8, Theorem 3.9]).

It is possible to extend the FKG inequality introduced in Proposition 2.1.7 to this setting. Let us suppose now that the Boolean model is driven by a homogeneous Poisson point process and denote by \mathbb{P}_λ its law. Given two realizations of the model $\omega = (\xi, \{r_x\})$ and $\omega' = (\xi', \{r'_x\})$, we say that $\omega \preceq \omega'$ if and only if $\xi \subset \xi'$ and for any point x of ξ we have $r_x \leq r'_x$. An event A is said to be increasing (respectively decreasing) if $\mathbb{1}_A(\omega) \leq \mathbb{1}_A(\omega')$ (respectively $\mathbb{1}_A(\omega) \geq \mathbb{1}_A(\omega')$) whenever $\omega \preceq \omega'$.

With these definitions Proposition 2.1.7 is transferred to this context in the following way (see [8, Theorem 2.2]).

Proposition 2.2.2 (FKG inequality for the Boolean model). *If A, B are both increasing or both decreasing events, then*

$$\mathbb{P}_\lambda(A \cap B) \geq \mathbb{P}_\lambda(A)\mathbb{P}_\lambda(B),$$

where \mathbb{P}_λ is the law of the model.

Bibliography

- [1] H. Duminil-Copin, A. Raoufi, V. Tassion. *Subcritical phase of d -dimensional Poisson-Boolean percolation and its vacant set*. Preprint available on arXiv as arXiv:1805.00695 (2018).
- [2] A. Faggionato, H.A. Mimun. *Connection probabilities in Poisson random graphs with uniformly bounded edges*. ALEA, Volume XVI, pp. 463–486 (2019).
- [3] R. Fitzner, R. Van Der Hofstad. *Mean-field behavior for nearest-neighbor percolation in $d > 10$* . Electronic Journal of Probability, **2** (2017).
- [4] J-B. Gou  r  . *Subcritical regimes in the Poisson Boolean model of continuum percolation*. Ann. Probab., **36** (4), pp. 1209–1220 (2008).
- [5] G.R. Grimmett, *Percolation*. Die Grundlehren der mathematischen Wissenschaften **321**. Second edition, Springer Verlag, Berlin (1999).
- [6] G.R. Grimmett, D.R. Stirzaker. *Probability and Random Processes*. Second edition, Oxford University Press, Oxford, Third edition (2001).
- [7] T. Hara, G. Slade. *Mean-field critical behaviour for percolation in high dimensions*. Comm. Math. Phys., **128**, pp. 333–391, (1990).
- [8] R. Meester, R. Roy. *Continuum percolation*. Cambridge Tracts in Mathematics **119**. First edition, Cambridge University Press, Cambridge (1996).

Chapter 3

Randomized algorithms: an application to Bernoulli bond percolation

In the last years many results in percolation have been proved again with different techniques which have much simplified the proofs. Moreover these new techniques have been very useful to prove new results in percolation and in other fields. For example, one of the most important result proved in the eighties is Menshikov's Theorem which establishes that in the subcritical regime for the Bernoulli bond-percolation the probability that the origin is connected to points at uniform distance n decays exponentially fast in n . The proof of such a result is really long and involves a lot of technical tools. Recently H. Duminil-Copin et al. have developed new techniques based on randomized algorithms and have consequently simplified many proofs and proved new results concerning the "sharpness of the phase transition" for many models. In this chapter we focus on this new technique showing its application to the Bernoulli bond percolation to obtain the same result of Menshikov as described in [1] (see also [3] and [4]). The final result will be Theorem 3.1.4 below.

3.1 Randomized algorithms

In theoretical computer science it is often really hard to calculate the computational complexity of problems. Computer scientists introduced the so-called randomized algorithms to simplify this issue. Informally speaking, a randomized algorithm associated to a Boolean function f of n variables takes $\omega \in \{0, 1\}^n$ as an input and reveals algorithmically the value of ω at different coordinates one by one stopping when the information revealed is enough to determine $f(\omega)$ as output. At each step, which coordinate will be revealed next depends on the values of ω revealed so far. The question is to determine how many bits of information must be revealed before the algorithm stops.

Formally speaking, a randomized algorithm is defined as follows. Consider a finite set E of cardinality n . A *randomized algorithm* (or *decision tree*) $T := (e_1, \{\psi_t\}_{t=2}^n)$ takes $\omega \in \{0, 1\}^E$ as an input and gives back an ordered sequence $e = (e_1, \dots, e_n)$

3. Randomized algorithms: an application to Bernoulli bond percolation

constructed inductively as follows: for any t integer with $2 \leq t \leq n$,

$$e_t = \psi_t(e_{[t-1]}, \omega_{e_{[t-1]}}) \in E \setminus \{e_1, \dots, e_{t-1}\},$$

where

$$e_{[t]} := (e_1, \dots, e_t), \quad \omega_{e_{[t]}} = (\omega_{e_1}, \dots, \omega_{e_t})$$

and ψ_t is a function interpreted as the *decision rule* at time t , that is ψ_t takes the location and the value of the bits for the first $t - 1$ steps of the procedure and decides of the next bit to examine.

For $f : \{0, 1\}^E \rightarrow \mathbb{R}$, define

$$\tau(\omega) = \tau_{f,T}(\omega) := \min\{t \geq 1 : \forall \omega' \in \{0, 1\}^E, \omega'_{e_{[t]}} = \omega_{e_{[t]}} \Rightarrow f(\omega) = f(\omega')\}, \quad (3.1)$$

that is, $\tau(\omega)$ is the smallest time that we need to determine the value of f .

The OSSS inequality, introduced for the first time in [6, Theorem 3.1], allows to compute an upper bound for the variance of a Boolean function in terms of the influence of the variables and the computational complexity of the randomized algorithm for this function (that in the following will be called “revelment” of the variables). We state below this inequality in the case of the Bernoulli bond percolation.

Let us consider the Bernoulli bond percolation on \mathbb{Z}^d in which each edge is open with probability $p \in [0, 1]$ independently from the other edges. Let us call \mathcal{G}_p the graph with vertex set given by \mathbb{Z}^d and edge set given by the open edges in the d -dimensional cubic lattice. Let us denote by $\mathbb{P}_p(\cdot)$, $\mathbb{E}_p[\cdot]$ and $\text{Var}_p(\cdot)$ the law, the associated expectation and variance of \mathcal{G}_p . The OSSS inequality for the Bernoulli percolation has the following form.

Theorem 3.1.1 (OSSS inequality for Bernoulli percolation). *Consider $p \in [0, 1]$ and a finite set of edges E . Fix a function $f : \{0, 1\}^E \rightarrow \{0, 1\}$ and an algorithm T to compute f . We have*

$$\text{Var}_p(f) \leq \sum_{e \in E} \delta_e^p(T) \text{Inf}_e^p(f),$$

where $\delta_e^p(T)$ and $\text{Inf}_e^p(f)$ are respectively the revelment of ω_e by T and the influence of ω_e on f . More precisely

$$\delta_e^p(T) = \mathbb{P}_p(\exists t \leq \tau(\omega) : e(t) = e),$$

$$\text{Inf}_e^p(f) := \mathbb{P}_p(f(\omega) \neq f(\omega^e)),$$

where $\omega^e \in \{0, 1\}^E$ is the randomization of ω characterized by the following conditions:

- $\omega_u^e = \omega_u$ for any $u \in E$ with $u \neq e$;
- ω_e^e has the same distribution of ω_e ;
- ω_e^e is independent on the family ω .

3.1 Randomized algorithms

We want to apply this inequality with $f(\omega) := \mathbb{1}_{\{0 \leftrightarrow \partial\Lambda_n\}}(\omega)$, where $\Lambda_n = [-n, n]^d \cap \mathbb{Z}^d$ and the event $\{0 \leftrightarrow \partial\Lambda_n\}$ occurs if there exists an open path that connects the origin to a point $x \in \partial\Lambda_n$.

Let us call $\theta_n(p) = \mathbb{P}_p(0 \leftrightarrow \partial\Lambda_n)$. We will use the OSSS inequality and Russo's formula (see Proposition 2.1.10) to prove the following claim.

Lemma 3.1.2. *It holds*

$$\theta'_n(p) \geq \frac{n}{8S_n(p)} \cdot \theta_n(p)(1 - \theta_n(p)), \quad (3.2)$$

where $S_n(p) := \sum_{k=0}^{n-1} \theta_k(p)$.

Proof. The proof is based on the Russo's formula and the OSSS inequality applied to a well chosen randomized algorithm determining $\mathbb{1}_{\{0 \leftrightarrow \Lambda_n\}}$. One may simply choose the trivial algorithm checking every edge of the box Λ_n . Unfortunately the revealment of the randomized algorithm would be 1 for every edge and the OSSS inequality would not bring us much information. We could also use the randomized algorithm that discovers the cluster of the origin starting from such a point. Edges far from the origin would then be revealed by the randomized algorithm if and only if one of their endpoints is connected to the origin. This provides a good bound for the revealment of edges far from the origin, but not for edges close to it. To avoid this problem, following [1], we will consider a family of random algorithms $\{T_k\}_{k=1}^n$, where T_k discovers the clusters in Λ_n intersecting $\partial\Lambda_k$. With this choice we will be able to show that the average of the revealment of $\{T_k\}_{k=1}^n$ for a fixed edge is always small. We divide the proof into three parts: in the first one we describe the algorithm and provide an upper bound for the revealment; in the second one we use Russo's formula to compute the derivative of θ_n and we relate it to the influence term in the OSSS inequality; in the final part we apply the OSSS inequality in which we insert the estimates obtained in the previous parts.

• **Construction of the algorithm and upper bound on the average of the revealments:** For $1 \leq k \leq n$ we wish to construct a randomized algorithm T_k determining $\mathbb{1}_{\{0 \leftrightarrow \partial\Lambda_n\}}$ such that for any edge $e = \{u, v\}$ it holds

$$\delta_e^p(T_k) \leq \mathbb{P}_p(u \leftrightarrow \partial\Lambda_k) + \mathbb{P}_p(v \leftrightarrow \partial\Lambda_k). \quad (3.3)$$

We describe the randomized algorithm T_k which explores the open clusters in Λ_n intersecting $\partial\Lambda_k$.

We construct three growing sequences $\partial\Lambda_k \subset V_0 \subset V_1 \subset \dots \subset V$, $\emptyset = F_0 \subset F_1 \subset \dots \subset E_n$ and $\emptyset = W_0 \subset W_1 \subset \dots \subset E_n$, where $V := \Lambda_n$ and $E_n := \{\{x, y\} \in E \mid x, y \in \Lambda_n\}$. At step t , V_t represents the set of the vertexes that the randomized algorithm have found to be connected to $\partial\Lambda_k$ up to time t , F_t is the set of the explored edges discovered by T_k until time t , W_t is the set of open edges discovered by T_k until time t that have their endpoints in V_t .

Fix an ordering of the edges in E_n . Set $V_0 = \partial\Lambda_k$ and $F_0 = W_0 = \emptyset$. Assuming that V_t , F_t and W_t have been constructed, we define the decision rule ψ_{t+1} distinguishing between two cases:

3. Randomized algorithms: an application to Bernoulli bond percolation

(C1) if there exists an edge $e = \{x, y\} \in E_n \setminus F_t$ with $x \in V_t$ and $y \notin V_t$ (if there is more than one edge that satisfies these hypotheses, pick the smallest one for the ordering), then define $e_{t+1} := e = \psi_{t+1}(e_{[t]}, \omega_{e_{[t]}})$, $F_{t+1} = F_t \cup \{e\}$ and

$$(V_{t+1}, W_{t+1}) := \begin{cases} (V_t \cup \{x\}, W_t \cup \{e\}), & \text{if } \omega_e = 1; \\ (V_t, W_t), & \text{otherwise.} \end{cases}$$

(C2) if e does not exist, define $T := t$ and the algorithm stops.

If $0 \in V_T$ and there exists a path from 0 to $V_T \cap \partial\Lambda_n$ inside the graph (V_T, W_T) , then give as output “ $\mathbb{1}_{\{0 \leftrightarrow \partial\Lambda_n\}} = 1$ ”, otherwise “ $\mathbb{1}_{\{0 \leftrightarrow \partial\Lambda_n\}} = 0$ ”.

Note that $T < \infty$ since E_n is finite and $F_T \subseteq E_n$. Note also that the algorithm discovers all the open clusters in Λ_n intersecting $\partial\Lambda_k$.

We claim that the algorithm T_k is correct for any $k = 1, 2, \dots, n$ (i.e. it determines whether or not the event $\{0 \leftrightarrow \partial\Lambda_n\}$ occurs). Indeed, if it gives output “ $\mathbb{1}_{\{0 \leftrightarrow \partial\Lambda_n\}} = 1$ ”, since (V_T, W_T) is a subgraph of \mathcal{G}_p , by construction there exists an open path from 0 to $\partial\Lambda_n$ and hence the event $\{0 \leftrightarrow \partial\Lambda_n\}$ occurs. Moreover, if the event $\{0 \leftrightarrow \partial\Lambda_n\}$ takes place, then there exists an open path π that connects 0 to a point $x \in \partial\Lambda_n$. Since $1 \leq k \leq n$, such a path must intersect $\partial\Lambda_k$ and hence 0 and x are contained in the same cluster intersecting $\partial\Lambda_k$. Since the algorithm T_k reveals all the open clusters intersecting $\partial\Lambda_k$, it discovers also the path π . Hence, when it stops, it must give as output “ $\mathbb{1}_{\{0 \leftrightarrow \partial\Lambda_n\}} = 1$ ”. So we have shown that the algorithm is correct and it stops in a finite number of steps.

Note that τ (see (3.1)) is not greater than T and hence (3.3) is satisfied. Moreover given $u \in \Lambda_n$

$$\sum_{k=1}^n \mathbb{P}_p(u \leftrightarrow \partial\Lambda_k) \leq \sum_{k=1}^n \mathbb{P}_p(u \leftrightarrow \partial\Lambda_{|k-d(u,0)|}(u)) \leq 2S_n(p),$$

where $d(u, 0)$ is the uniform distance between u and 0 and $\Lambda_{|k-d(u,0)|}(u) := u + \Lambda_{|k-d(u,0)|}$. Hence given an edge $e = \{u, v\}$

$$\frac{1}{n} \sum_{k=1}^n \delta_e(T_k) \leq \frac{1}{n} \sum_{k=1}^n [\mathbb{P}_p(u \leftrightarrow \partial\Lambda_k) + \mathbb{P}_p(v \leftrightarrow \partial\Lambda_k)] \leq \frac{4S_n(p)}{n}. \quad (3.4)$$

•**Derivative of θ_n** : Let us consider the following ordering on the space $\Omega = \{0, 1\}^E$: given $\omega, \omega' \in \Omega$ we say that $\omega \preceq \omega'$ if $\omega_e \leq \omega'_e$ for any $e \in E$. Note that the event $\{0 \leftrightarrow \partial\Lambda_n\}$ is increasing w.r.t. \preceq and hence we can apply Russo’s formula (see Proposition 2.1.10) to obtain that

$$\begin{aligned} \theta'_n(p) &= \sum_{e \in E} \mathbb{P}_p(e \text{ is pivotal for the event } \{0 \leftrightarrow \partial\Lambda_n\}) = \\ &= \sum_{e \in E_n} \mathbb{P}_p(e \text{ is pivotal for the event } \{0 \leftrightarrow \partial\Lambda_n\}). \end{aligned} \quad (3.5)$$

Remember that e is pivotal for an event A and a configuration ω if $\mathbb{1}_A(\omega) \neq \mathbb{1}_A(\gamma^e)$, where $\gamma^e \in \Omega$ is defined by the following relation

$$\gamma_u^e := \begin{cases} \omega_u, & \text{if } u \neq e; \\ 1 - \omega_u, & \text{if } u = e. \end{cases}$$

3.1 Randomized algorithms

Recall the definition of influence and of ω^e given in Theorem 3.1.1. Note that, calling $A := \{0 \leftrightarrow \partial\Lambda_k\}$, we have

$$\begin{aligned} \text{Inf}_e^p(\mathbf{1}_A) &= \mathbb{P}_p(\mathbf{1}_A(\omega) \neq \mathbf{1}_A(\omega^e)) = \\ &= 2\mathbb{P}_p(\mathbf{1}_A(\omega) \neq \mathbf{1}_A(\omega^e), \omega_e = 1, \omega_e^e = 0) = \\ &= 2\mathbb{P}_p(\mathbf{1}_A(\omega) \neq \mathbf{1}_A(\gamma^e), \omega_e = 1, \omega_e^e = 0), \end{aligned} \quad (3.6)$$

The inequality $\mathbf{1}_A(\omega) \neq \mathbf{1}_A(\gamma^e)$ is equivalent to the fact that e is pivotal for the event A and the configuration ω . Moreover this event is independent from ω_e and ω_e^e . Hence (3.6) implies that

$$\text{Inf}_e^p(A) \leq 2\mathbb{P}_p(e \text{ is pivotal for the event } A). \quad (3.7)$$

So combining (3.5) and (3.6) we get

$$\theta'_n(p) \geq \frac{1}{2} \sum_{e \in E_n} \text{Inf}_e^p(\mathbf{1}_{\{0 \leftrightarrow \partial\Lambda_k\}}). \quad (3.8)$$

•Application of the OSSS inequality and conclusion of the proof: Let us consider the OSSS inequality for the algorithm T_k and the function $\mathbf{1}_{\{0 \leftrightarrow \partial\Lambda_n\}}$. Note that, even if defined Ω , such a function depends only on $\{\omega_e\}_{e \in E_n}$. So we can consider $\{0, 1\}^{E_n}$ as domain of the function $\mathbf{1}_{\{0 \leftrightarrow \partial\Lambda_n\}}$.

Observe that

$$\text{Var}_p(\mathbf{1}_{\{0 \leftrightarrow \partial\Lambda_n\}}) = \theta_n(p)(1 - \theta_n(p)). \quad (3.9)$$

Hence by the OSSS inequality

$$\theta_n(p)(1 - \theta_n(p)) \leq \sum_{e \in E_n} \delta_e^p(T_k) \text{Inf}_e^p(\mathbf{1}_{\{0 \leftrightarrow \partial\Lambda_n\}}). \quad (3.10)$$

Summing over $k = 1, \dots, n$ and dividing by n both the l.h.s. and the r.h.s. of (3.10), by (3.4) and (3.8) we get

$$\begin{aligned} \theta_n(p)(1 - \theta_n(p)) &\leq \sum_{e \in E_n} \left(\frac{1}{n} \sum_{k=1}^n \delta_e^p(T_k) \right) \text{Inf}_e^p(\mathbf{1}_{\{0 \leftrightarrow \partial\Lambda_n\}}) \\ &\leq \frac{4S_n(p)}{n} \sum_{e \in E_n} \text{Inf}_e^p(\mathbf{1}_{\{0 \leftrightarrow \partial\Lambda_k\}}) \\ &\leq \frac{4S_n(p)}{n} 2\theta'_n(p) = \frac{8S_n(p)}{n} \theta'_n(p) \end{aligned} \quad (3.11)$$

and hence

$$\theta'_n(p) \geq \frac{n}{8S_n(p)} \theta_n(p)(1 - \theta_n(p)) \quad (3.12)$$

that concludes the proof. \square

We now want to use Lemma 3.1.2 to prove the sharpness of the phase transition and hence Menshikov's Theorem. We need the following general lemma (see [2, Lemma 3]).

3. Randomized algorithms: an application to Bernoulli bond percolation

Lemma 3.1.3. *Consider a converging sequence of increasing differentiable functions $f_n : [0, x_0] \rightarrow (0, M]$ satisfying*

$$f'_n \geq \frac{n}{\sum_{k=0}^{n-1} f_k} \cdot f_n \quad \forall n \geq 1. \quad (3.13)$$

Then there exists $x_1 \in [0, x_0]$ such that

- *for any $x < x_1$, there exists $c_x > 0$ such that for any n large enough $f_n(x) \leq e^{-c_x n}$;*
- *for any $x > x_1$ the function $f := \lim_{n \rightarrow \infty} f_n$ satisfies $f(x) \geq x - x_1$.*

Note that $\theta_n : [0, 1] \rightarrow [0, 1]$ is an increasing function and it is also differentiable since it is a polynomial in p . Moreover $\lim_{n \rightarrow \infty} \theta_n(p) = \theta(p) := \mathbb{P}_p(0 \leftrightarrow \infty)$, where $0 \leftrightarrow \infty$ means that the origin is connected to arbitrarily far points through an open path. Let us consider $p_0 \in (p_c(d), 1]$, where $p_c(d)$ is the critical probability for the Bernoulli bond percolation in \mathbb{Z}^d . Since $\theta_n(p)$ is increasing in p and decreasing in n , we have that $\theta_n(p) \leq \theta_1(p_0) < 1$ for all $p \in [0, p_0]$ and $n \geq 1$. So we have $1 - \theta_n(p) \geq 1 - \theta_1(p_0) > 0$ and hence (3.12) implies

$$\theta'_n(p) \geq \frac{n}{8S_n(p)} \theta_n(p)(1 - \theta_1(p_0)) = \frac{n}{S_n(p)} \cdot \alpha \theta_n(p), \quad (3.14)$$

where $\alpha := \frac{1 - \theta_1(p_0)}{8} > 0$.

So we can apply Lemma 3.1.3 with $f_n := \alpha^{-1} \theta_n : [0, p_0] \rightarrow (0, M]$, with $M := \alpha^{-1} \theta_1(p_0)$, noting that the condition (3.13) is equivalent to (3.14) and hence there exists $p^* \in [0, p_0]$ such that

- (i) for any $p < p^*$ there exists $c = c(p, p_0) > 0$ such that for any n large enough $\theta_n(p) \leq e^{-cn}$;
- (ii) there exists a constant $\beta = \beta(p_0) \in [0, 1)$ such that for any $p > p^*$ it holds $\mathbb{P}_p(0 \leftrightarrow \infty) \geq \beta(p - p^*)$.

Since $p_0 > p_c(d)$ and

$$\mathbb{P}_p(0 \leftrightarrow \infty) \begin{cases} = 0, & p < p_c(d), \\ > 0, & p > p_c(d), \end{cases}$$

we have that $p_c(d) = p^*$ and Menshikov's Theorem follows from item (i).

We recap what has been proved (which covers also the supercritical case).

Theorem 3.1.4. *The following hold:*

- *for any $p < p_c(d)$ there exists a constant $c = c(p) > 0$ such that for any n large enough $\theta_n(p) \leq e^{-cn}$.*
- *there exists a constant $\beta \in [0, 1)$ such that for any $p > p_c(d)$ it holds $\mathbb{P}_p(0 \leftrightarrow \infty) \geq \beta(p - p_c(d))$.*

Bibliography

- [1] H. Duminil-Copin. *Lectures on the Ising and Potts models on the hypercubic lattice*. Preprint available on arXiv as arXiv:1707.00520 (2017).
- [2] H. Duminil-Copin, A. Raoufi, V. Tassion. *Exponential decay of connection probabilities for subcritical Voronoi percolation in \mathbb{R}^d* . To appear on Prob. Theory Rel. Fields., **173**, Issue 1-2, pp. 479–490 (2019).
- [3] H. Duminil-Copin, V. Tassion. *A new proof of the sharpness of the phase transition for Bernoulli percolation and the Ising model*. Comm. Math. Phys., **343(2)**, pp. 725–745 (2016).
- [4] H. Duminil-Copin, V. Tassion. *A new proof of the sharpness of the phase transition for Bernoulli percolation on \mathbb{Z}^d* . Enseignement Mathématique, **62(1-2)**, pp. 199–206 (2016).
- [5] G.R. Grimmett, *Percolation*. Die Grundlehren der mathematischen Wissenschaften **321**. Second edition, Springer Verlag, Berlin (1999).
- [6] R. O’Donnell, M. Saks, O. Schramm, R. Servedio. *Every decision tree has an influential variable*. FOCS’05, pp. 31–39 (2005).

Chapter 4

Connection probabilities in Poisson random graphs with uniformly bounded edges

Alessandra Faggionato and Hlalo Alfie Mimun

Published on ALEA, Volume XVI, pp. 463–486 (2019).

We consider random graphs with uniformly bounded edges on a Poisson point process conditioned to contain the origin. In particular we focus on the random connection model, the Boolean model and the Miller–Abrahams random resistor network with lower–bounded conductances. The latter is relevant for the analysis of conductivity by Mott variable range hopping in strongly disordered systems. By using the method of randomized algorithms developed by Duminil–Copin et al. we prove that in the subcritical phase the probability that the origin is connected to some point at distance n decays exponentially in n , while in the supercritical phase the probability that the origin is connected to infinity is strictly positive and bounded from below by a term proportional to $(\lambda - \lambda_c)$, λ being the density of the Poisson point process and λ_c being the critical density.

4.1 Introduction

We take the homogeneous Poisson point process (PPP) ξ on \mathbb{R}^d , $d \geq 2$, with density λ conditioned to contain the origin. More precisely, ξ is sampled according to the Palm distribution associated to the homogeneous PPP with density λ , which is the same as sampling a point configuration ζ according to the homogeneous PPP with density λ and setting $\xi := \zeta \cup \{0\}$.

We start with two random graphs with vertex set ξ : the random connection model $\mathcal{G}_{\text{RC}} = (\xi, \mathcal{E}_{\text{RC}})$ with radial connection function g [9] and the Miller–Abrahams random resistor network $\mathcal{G}_{\text{MA}} = (\xi, \mathcal{E}_{\text{MA}})$ with lower–bounded conductances (above, \mathcal{E}_{RC} and \mathcal{E}_{MA} denote the edge sets).

The edges in \mathcal{E}_{RC} are determined as follows. Recall that the connection function $g : (0, +\infty) \rightarrow [0, 1]$ is a given measurable function. Given a realization ξ , for any unordered pair of sites $x \neq y$ in ξ one declares $\{x, y\}$ to be an edge (i.e. one sets $\{x, y\} \in \mathcal{E}_{\text{RC}}$) with probability $g(|x - y|)$, independently from the other pairs of sites.

4. Connection probabilities in Poisson random graphs

In what follows, we write $\mathbb{P}_{0,\lambda}^{\text{RC}}$ for the law of the above random connection model (shortly, RC model).

We now move to the Miller–Abrahams random resistor network, explaining first the physical motivations. This random resistor network has been introduced by Miller and Abrahams in [10] as an effective model to study the conductivity via Mott variable range hopping in disordered solids, as doped semiconductors, in the regime of strong Anderson localization and low impurity density. It has been further developed by Ambegoakar et al. [1] to give a more robust derivation of Mott’s law for the low temperature asymptotics of the conductivity [6, 5, 7, 12, 13]. Recently developed new materials, as new organic doped semiconductors, enter into this class.

The Miller–Abrahams random resistor network is obtained as follows. Given a realization ξ of a generic simple point process, one samples i.i.d. random variables $(E_x)_{x \in \xi}$, called *energy marks*, and attaches to any unordered pair of sites $x \neq y$ in ξ a filament of conductance [1, 12]

$$\exp \left\{ -\frac{2}{\gamma}|x-y| - \frac{\beta}{2}(|E_x| + |E_y| + |E_x - E_y|) \right\}. \quad (4.1)$$

Above γ denotes the localization length and β the inverse temperature (in what follows we take $\gamma = 2$ and $\beta = 2$ without loss of generality). Note that the skeleton of the resistor network is the complete graph on ξ . In the physical context of inorganic doped semiconductors, the relevant distributions of the energy marks have density function $c|E|^\alpha dE$ supported on some interval $[-a, a]$, c being the normalization constant, where $\alpha \geq 0$ and $a > 0$. In this case, the physical Mott’s law states that the conductivity scales as $\exp\{-C\beta^{\frac{\alpha+1}{\alpha+1+d}}\}$ for some β –independent constant C . We refer to [5] for a conjectured characterization of the constant C .

A key tool (cf. [6]) to rigorously upper bound the conductivity of the Miller–Abrahams resistor network is provided by the control on the size of the clusters formed by edges with high conductance, when these clusters remain finite, hence in a subcritical regime. In particular, we are interested in the subgraph given by the edges $\{x, y\}$ such that

$$|x-y| + |E_x| + |E_y| + |E_x - E_y| \leq \zeta, \quad (4.2)$$

for some threshold $\zeta > 0$ for which the resulting subgraph does not percolate.

We point out that a lower bound of the conductivity would require (cf. [7]) a control on the left–right crossings in the above subgraph when it percolates (we will address this problem in a separate work). To catch the constant C in Mott’s law for the Miller–Abrahams resistor network on a Poisson point process, one needs more information on the connection probabilities and on the left–right crossings than what used in [6, 7]. For the connection probabilities this additional information will be provided by Theorem 1 below.

As discussed in [5], by the scaling properties of the model, instead of playing with ζ we can fix the threshold ζ and vary the Poisson density λ .

We now give a self–contained mathematical definition of $\mathcal{G}_{\text{MA}} = (\xi, \mathcal{E}_{\text{MA}})$. To this aim we fix a probability distribution ν on \mathbb{R} and a threshold $\zeta > 0$. Given

4.1 Introduction

a realization ξ of the λ -homogeneous PPP conditioned to contain the origin, we consider afresh a family of i.i.d. random variables $(E_x)_{x \in \xi}$ with common distribution ν . For any unordered pair of sites $x \neq y$ in ξ , we declare $\{x, y\}$ to be an edge (i.e. we set $\{x, y\} \in \mathcal{E}_{\text{MA}}$) if (4.2) is satisfied. In what follows, we write $\mathbb{P}_{0,\lambda}^{\text{MA}}$ for the law of the above random graph, and we will refer to this model simply as the MA model.

We introduce the function h defined as

$$h(u) := P(|E| + |E'| + |E - E'| \leq \zeta - u), \quad u \in (0, +\infty), \quad (4.3)$$

where E, E' are i.i.d. random variables with law ν . In what follows we will use the following fact:

Lemma 4.1.1. *The following properties are equivalent:*

- (i) *The function h is not constantly zero;*
- (ii) *The probability measure ν satisfies*

$$\nu((-\zeta/2, \zeta/2)) > 0. \quad (4.4)$$

The proof of Lemma 4.1.1 is given in Section 4.2.

To state our main results we fix some notation. We write S_n for the boundary of the box $[-n, n]^d$, i.e. $S_n = \{x \in \mathbb{R}^d : \|x\|_\infty = n\}$ and we give the following definition:

Definition 4.1.2. *Given a point $x \in \mathbb{R}^d$ and given a graph $G = (V, E)$ in \mathbb{R}^d , we say that x is connected to S_n in the graph G , and write $x \leftrightarrow S_n$, if $x \in V$ and x is connected in G to some vertex $y \in V$ such that (i) $\|y\|_\infty \geq n$ if $\|x\|_\infty \leq n$ or (ii) $\|y\|_\infty \leq n$ if $\|x\|_\infty > n$. We say that a point $x \in \mathbb{R}^d$ is connected to infinity in G , and write $x \leftrightarrow \infty$, if $x \in V$ and for any $\ell > 0$ there exists $y \in V$ with $\|y\|_\infty \geq \ell$ such that x and y are connected in G .*

Both the RC model when $0 < \int_0^\infty r^{d-1}g(r)dr < +\infty$ and the MA model when (4.4) is satisfied exhibit a phase transition at some critical density $\lambda_c \in (0, \infty)$:

$$\begin{cases} \lambda < \lambda_c & \implies \mathbb{P}_{0,\lambda}^{\text{RC/MA}}(0 \leftrightarrow \infty) = 0, \\ \lambda > \lambda_c & \implies \mathbb{P}_{0,\lambda}^{\text{RC/MA}}(0 \leftrightarrow \infty) > 0. \end{cases} \quad (4.5)$$

Above, and in what follows, we do not stress the dependence of the constants on the dimension d , the connection function g (for the RC model), the distribution ν and the threshold ζ (for the MA model). The above phase transition (4.5) follows from [9, Theorem 6.1] for the RC model and from Proposition 4.2.2 in Section 4.2 for the MA model.

Following the recent developments [3, 4] on percolation theory by means of decision trees (random algorithms) we can improve the knowledge of the above phase transition by providing more detailed information on the behavior of the connection probabilities. To state our main result we need to introduce the concept of *good function*:

Definition 4.1.3. A function $f : (0, +\infty) \rightarrow [0, 1]$ is called good if f is positive on a subset of positive Lebesgue measure and if there is a finite family of points $0 < r_1 < r_2 < \dots < r_{m-1} < r_m$ such that (i) $f(r) = 0$ for $r \geq r_m$ and (ii) f is uniformly continuous on (r_i, r_{i+1}) for all $i = 0, \dots, m-1$, where $r_0 := 0$.

We point out that the function h defined in (4.3) is weakly decreasing and satisfies $h(u) = 0$ for $u > \zeta$. In particular, due to Lemma 4.1.1, h is positive on a subset of positive Lebesgue measure if and only if (4.4) is satisfied. Moreover, due to Lemma 4.1.1, if ν has a probability density which is bounded and which is strictly positive on a subset of $(-\zeta/2, \zeta/2)$ of positive Lebesgue measure, then the function h is good. In particular, if ν has density function $c|E|^\alpha dE$ supported on some interval $[-a, a]$ (as in the physically relevant cases), then h is good.

Theorem 1. Consider the random connection model \mathcal{G}_{RC} with good radial connection function g . Consider the Miller–Abrahams model \mathcal{G}_{MA} , associated to the distribution ν and the threshold ζ , and assume that the function h defined in (4.3) is good (cf. Lemma 4.1.1). In both cases, let the vertex set be given by a Poisson point process with density λ conditioned to contain the origin.

Then for both models the following holds:

- (Subcritical phase) For any $\lambda < \lambda_c$ there exists $c = c(\lambda) > 0$ such that

$$\mathbb{P}_{0,\lambda}^{\text{RC/MA}}(0 \leftrightarrow S_n) \leq e^{-cn}, \quad \forall n \in \mathbb{N}. \quad (4.6)$$

- (Supercritical phase) There exists $C > 0$ such that

$$\mathbb{P}_{0,\lambda}^{\text{RC/MA}}(0 \leftrightarrow \infty) \geq C(\lambda - \lambda_c), \quad \forall \lambda > \lambda_c. \quad (4.7)$$

4.1.1 Extension to other Poisson models

We point out that the arguments presented in the proof of Theorem 1 are robust enough to be applied to other random graphs on the Poisson point process with uniformly bounded edge length. We discuss here the Poisson Boolean model \mathcal{G}_B [9]. Let $\nu \neq \delta_0$ be a probability distribution with bounded support in $[0, \infty)$. Given a realization ξ of the PPP with density λ conditioned to contain the origin, let $(A_x)_{x \in \xi}$ be i.i.d. random variables with common law ν . The graph $\mathcal{G}_B = (\xi, \mathcal{E}_B)$ is then defined by declaring $\{x, y\}$, with $x \neq y$ in ξ , to be an edge in \mathcal{E}_B if and only if $|x - y| \leq A_x + A_y$. It is known that the model exhibits a phase transition for some $\lambda_c \in (0, +\infty)$ as in (4.5).

The reader can check that the proof of Theorem 1 for the MA model can be easily adapted to the Boolean model (the latter is even simpler) if one takes now

$$h(u) := P(u \leq A + A'), \quad u \in (0, +\infty), \quad (4.8)$$

where A, A' are i.i.d. with law ν , and if one assumes h to be good.

We collect the above observations in the following theorem:

Theorem 2. Consider the Poisson Boolean model \mathcal{G}_B with radius law $\nu \neq \delta_0$ having bounded support and such that the function h defined in (4.8) is good. Let the vertex set be given by a Poisson point process with density λ conditioned to contain the origin. Then the thesis of Theorem 1 remains true in this context, where λ_c is the critical density for the Poisson Boolean model [9].

We point out that the above result has been obtained, in part with different techniques, in [14].

4.2 Phase transition in the MA model

In this section we prove Lemma 4.1.1 and also show that the phase transition (4.5) takes place in the MA model.

We start with Lemma 4.1.1:

Proof of Lemma 4.1.1. Let us show that Items (i) and (ii) are equivalent. Suppose first that (4.4) is violated and let E, E' be as in (4.3). Then a.s. we have $|E| \geq \zeta/2$ and $|E'| \geq \zeta/2$, thus implying that $P(|E| + |E'| + |E - E'| \geq \zeta) = 1$ and therefore $h(u) = 0$ for any $u > 0$. Suppose now that (4.4) is satisfied. Then it must be $\nu([0, \zeta/2]) > 0$ or $\nu((-\zeta/2, 0]) > 0$. We analyze the first case, the other is similar. Consider the measure ν_* given by ν restricted to $[0, \zeta/2]$. Let ℓ be the minimum of the support of ν_* . Then for each $\delta > 0$ it holds $\nu([\ell, \ell + \delta]) > 0$. Since $\ell < \zeta/2$ we can fix $\delta > 0$ such that $2\ell + 3\delta < \zeta$. Take now E, E' i.i.d. random variables with law ν . If $E, E' \in [\ell, \ell + \delta]$, then $|E| + |E'| + |E - E'| \leq 2\ell + 3\delta \leq \zeta - u$ for any $u > 0$ such that $2\ell + 3\delta \leq \zeta - u$ (such a u exists). This implies that $h(u) \geq P(E, E' \in [\ell, \ell + \delta]) = \nu([\ell, \ell + \delta])^2 > 0$, hence h is not constantly zero. This completes the proof that Items (i) and (ii) are equivalent. \square

Remark 4.2.1. *We point out that in the above proof we have shown the following technical fact which will be used in the proof of Proposition 4.2.2. If $\nu([0, \zeta/2]) > 0$, then there are $\ell \geq 0$ and $\delta > 0$ such that (i) $2\ell + 3\delta < \zeta$, (ii) $\nu([\ell, \ell + \delta]) > 0$, (iii) if $e, e' \in [\ell, \ell + \delta]$ then $u + |e| + |e'| + |e - e'| \leq \zeta$ for any $u \in (0, \zeta - 2\ell - 3\delta]$. On the other hand, if $\nu((-\zeta/2, 0]) > 0$, then there are $\ell \geq 0$ and $\delta > 0$ such that (i) $2\ell + 3\delta < \zeta$, (ii) $\nu([- \ell - \delta, -\ell]) > 0$, (iii) if $e, e' \in [-\ell - \delta, -\ell]$ then $u + |e| + |e'| + |e - e'| \leq \zeta$ for any $u \in (0, \zeta - 2\ell - 3\delta]$. Note that, due to Lemma 4.1.1, when $h \not\equiv 0$ the above two cases are exhaustive.*

Proposition 4.2.2. *There exists $\lambda_c \in (0, +\infty)$ such that the phase transition (4.5) takes place in the MA model when h is not constantly zero, equivalently when (4.4) holds (cf. Lemma 4.1.1).*

The proof of the above proposition is a generalization of the one given in [5], in which ν is the physically relevant distribution $\nu = c|E|^\alpha dE$.

Proof. Since two Poisson point processes (possibly conditioned to contain the origin) with density $\lambda < \lambda'$ can be coupled in a way that the one with smaller density is contained in the other, we get that the function $\phi(\lambda) := \mathbb{P}_{0, \lambda}^{\text{MA}}(0 \leftrightarrow \infty)$ is weakly increasing. Hence, to get the thesis it is enough to exhibit positive λ_m, λ_M such that $\phi(\lambda_m) = 0$ and $\phi(\lambda_M) > 0$.

Let us consider the graph $\mathcal{G}_{\text{MA}}^* = (\xi, \mathcal{E}_{\text{MA}}^*)$ where a pair of sites $x \neq y$ in ξ forms an edge $\{x, y\} \in \mathcal{E}_{\text{MA}}^*$ if and only if $|x - y| \leq \zeta$. Trivially, $\mathcal{G}_{\text{MA}} \subset \mathcal{G}_{\text{MA}}^*$. On the other hand, by the property of the Poisson Boolean model, the event $\{0 \leftrightarrow \infty \text{ in } \mathcal{G}_{\text{MA}}^*\}$ has probability zero for λ small enough. This proves that $\phi(\lambda) = 0$ for λ small enough.

Now take ℓ, δ as in Remark 4.2.1. We treat the case $\nu([0, \zeta/2]) > 0$, the complementary case $\nu((-\zeta/2, 0]) > 0$ is similar. Given a realization ξ of the point process

and given random variables $(E_x)_{x \in \xi}$ as in the Introduction, we build a new graph $\hat{\mathcal{G}}_{\text{MA}} = (\hat{\mathcal{V}}_{\text{MA}}, \hat{\mathcal{E}}_{\text{MA}})$ as follows. As vertex set $\hat{\mathcal{V}}_{\text{MA}}$ we take $\{x \in \xi : E_x \in [\ell, \ell + \delta]\}$. We say that a pair of sites $x \neq y$ in $\hat{\mathcal{V}}_{\text{MA}}$ forms an edge $\{x, y\} \in \hat{\mathcal{E}}_{\text{MA}}$ if and only if $|x - y| \leq \zeta - 2\ell - 3\delta$. By Remark 4.2.1 if $\{x, y\} \in \hat{\mathcal{E}}_{\text{MA}}$ then (4.2) is satisfied, and therefore $\{x, y\} \in \mathcal{E}_{\text{MA}}$. We have therefore that $\hat{\mathcal{G}}_{\text{MA}} \subset \mathcal{G}_{\text{MA}}$. On the other hand, with positive probability we have $E_0 \in [\ell, \ell + \delta]$, i.e. $0 \in \hat{\mathcal{V}}_{\text{MA}}$, and conditioning to this event $\hat{\mathcal{G}}_{\text{MA}}$ becomes a Boolean model on a PPP with density $\lambda\nu([\ell, \ell + \delta])$ conditioned to contain the origin, where two points x, y are connected by an edge if and only if $|x - y| \leq \zeta - 2\ell - 3\delta$. By the properties of the Poisson Boolean model [9] if λ is large enough with positive probability we have $0 \leftrightarrow \infty$ in $\hat{\mathcal{G}}_{\text{MA}}$. Since $\hat{\mathcal{G}}_{\text{MA}} \subset \mathcal{G}_{\text{MA}}$, this proves that $\phi(\lambda) > 0$ for λ large enough. \square

4.3 Outline of the proof of Theorem 1

In this section we outline the proof of Theorem 1. Further details are given in the remaining sections.

Warning 4.3.1. *Without loss of generality we assume, here and in what follows, that $g(r) = 0$ for $r \geq 1$ in the RC model, and that $\zeta < 1$ in the MA model.*

4.3.1 Probability $\mathbb{P}_{0,\lambda}$ and \mathbb{P}_λ

We write \mathcal{N} for the space of possible realizations of a point process in \mathbb{R}^d [2]. We denote by P_λ the law on \mathcal{N} of the λ -homogeneous Poisson point process and by $P_{0,\lambda}$ the associated Palm distribution. As in [9, Sections 1.4, 1.5], given $k \in \mathbb{Z}^d$ and $n \in \mathbb{N}$, we define the binary cube of order n

$$\mathcal{K}(n, k) := \prod_{i=1}^d (k_i 2^{-n}, (k_i + 1) 2^{-n}).$$

Given $x \in \mathbb{R}^d$ there exists a unique binary cube of order n , say $\mathcal{K}(n, k(n, x))$, that contains x . Moreover, both for P_λ -a.e. ξ and for $P_{0,\lambda}$ -a.e. ξ , for each $x \in \xi$ there exists a unique smallest number $n(x)$ such that $\mathcal{K}(n(x), k(n(x), x))$ contains no other point of ξ .

We then consider a separate probability space (Σ, P) . For the RC model we take $\Sigma = [0, 1]^{\mathcal{R}}$, $\mathcal{R} = \{((n_1, k_1), (n_2, k_2)) : n_1, n_2 \in \mathbb{N}, k_1, k_2 \in \mathbb{Z}^d\}$, and let P be the product probability measure on Σ with marginals given by the uniform distribution on $[0, 1]$. For the MA resistor network we take $\Sigma = \mathbb{R}^{\mathcal{R}}$, $\mathcal{R} = \{(n, k) : n \in \mathbb{N}, k \in \mathbb{Z}^d\}$, and let P be the product probability measure on Σ with marginals given by ν . Finally, we take the following probabilities on $\mathcal{N} \times \Sigma$:

$$\mathbb{P}_\lambda := P_\lambda \times P, \quad \mathbb{P}_{0,\lambda} := P_{0,\lambda} \times P.$$

We write σ for a generic element of Σ . When treating the RC model, given $x \neq y$ in ξ we shorten the notation by writing $\sigma_{x,y}$ for $\sigma_{(n_1, k_1), (n_2, k_2)}$ where

$$(n_1, k_1) := (n(x), k(n(x), x)), \quad (n_2, k_2) := (n(y), k(n(y), y)). \quad (4.9)$$

4.3 Outline of the proof of Theorem 1

Similarly, when treating the MA model, given $x \in \xi$ we write σ_x for $\sigma_{n,k}$ where $(n, k) = (n(x), k(n(x), x))$.

In what follows we write \prec_{lex} for the lexicographic order on \mathbb{R}^d . To a generic element $(\xi, \sigma) \in \mathcal{N} \times \Sigma$ we associate a graph $\mathcal{G} = (\mathcal{V}, \mathcal{E})$ defined as follows. We set $\mathcal{V} := \xi$ for the vertex set. In the RC model we define the edge set \mathcal{E} as the set of pairs $\{x, y\}$ with $x \prec_{\text{lex}} y$ in ξ such that $\sigma_{x,y} \leq g(|x - y|)$. When treating the MA model we define \mathcal{E} as the set of pairs $\{x, y\}$ with $x \neq y$ such that

$$|x - y| + |\sigma_x| + |\sigma_y| + |\sigma_x - \sigma_y| \leq \zeta.$$

Then the law of $\mathcal{G}(\xi, \sigma)$ with (ξ, σ) sampled according to $P_{0,\lambda}$ equals $\mathbb{P}_{0,\lambda}^{\text{RC}}$ in the RC model, while it equals $\mathbb{P}_{0,\lambda}^{\text{MA}}$ in the MA model. In particular, the phase transition (4.5) can be stated directly for the probability $\mathbb{P}_{0,\lambda}$, and to prove Theorem 1 it is enough to consider $\mathbb{P}_{0,\lambda}$ instead of $\mathbb{P}_{0,\lambda}^{\text{RC/MA}}$. Note that when (ξ, σ) is sampled according to \mathbb{P}_λ , the graph $\mathcal{G}(\xi, \sigma)$ gives a realization of $\mathcal{G}_{\text{RC}}/\mathcal{G}_{\text{MA}}$ with the exception that now ξ is sampled according to a λ -homogeneous Poisson point process.

4.3.2 Discretisation

We point out that, due to our assumptions, the graph \mathcal{G} has all edges of length strictly smaller than 1, both in the RC model and in the MA model.

Given a positive integer n and given $k = 0, 1, \dots, n$, we define the functions

$$\tilde{\theta}_k(\lambda) := \mathbb{P}_{0,\lambda}(0 \leftrightarrow S_k), \quad \tilde{\psi}_k(\lambda) := \lambda \tilde{\theta}_k(\lambda). \quad (4.10)$$

Warning 4.3.2. *Above, and in what follows, we adopt the convention that, when considering $\mathbb{P}_{0,\lambda}$ or the associated expectation $\mathbb{E}_{0,\lambda}$, graphical statements as “ $0 \leftrightarrow S_k$ ” refer to the random graph \mathcal{G} , if not stated otherwise. The same holds for \mathbb{P}_λ and \mathbb{E}_λ .*

We have $\tilde{\theta}_k(\lambda) = \mathbb{P}_{0,\lambda}(0 \leftrightarrow S_k) = \mathbb{P}_\lambda(0 \leftrightarrow S_k \text{ in } \mathcal{G}(\xi \cup \{0\}, \sigma))$. Due to [8, Thm. 1.1] (which remains valid when considering the additional random field σ), the derivative $\tilde{\theta}'_n(\lambda)$ of $\tilde{\theta}_n(\lambda)$ can be expressed as follows:

$$\tilde{\theta}'_n(\lambda) = \frac{1}{\lambda} \mathbb{E}_{0,\lambda}[|\text{Piv}_+(0 \leftrightarrow S_n) \setminus \{0\}|], \quad (4.11)$$

where $\text{Piv}_+(0 \leftrightarrow S_n)$ denotes the set of points which are (+)-pivotal for the event $0 \leftrightarrow S_n$. We recall that given an event A in terms of the graph \mathcal{G} and a configuration $(\xi, \sigma) \in \mathcal{N} \times \Sigma$, a point $x \in \mathbb{R}^d$ is called (+)-pivotal for the event A and the configuration (ξ, σ) , if (i) $x \in \xi$, (ii) the event A takes place for the graph $\mathcal{G}(\xi, \sigma)$, (iii) the event A does not take place in the graph obtained from $\mathcal{G}(\xi, \sigma)$ by removing the vertex x and all edges containing x .

Note that $\mathbb{P}_{0,\lambda}(0 \in \text{Piv}_+(0 \leftrightarrow S_n)) = \mathbb{P}_{0,\lambda}(0 \leftrightarrow S_n) = \tilde{\theta}_n(\lambda)$. Hence, from (4.11) we get

$$\tilde{\psi}'_n(\lambda) = \tilde{\theta}_n(\lambda) + \lambda \tilde{\theta}'_n(\lambda) = \mathbb{E}_{0,\lambda}[|\text{Piv}_+(0 \leftrightarrow S_n)|]. \quad (4.12)$$

The first step in the proof of Theorem 1 is to approximate the functions $\tilde{\psi}_n(\lambda)$ and $\tilde{\psi}'_n(\lambda)$ in terms of suitable random graphs built on a grid. To this aim, we

introduce the scale parameter ε of the form $\varepsilon = 1/m$, where $m \geq 2$ is an integer. Moreover we set

$$\begin{aligned}\Lambda_k &:= [-k, k]^d, \quad S_k := \partial\Lambda_k = \{x \in \mathbb{R}^d : \|x\|_\infty = k\}; \\ R_x^\varepsilon &:= x + [0, \varepsilon)^d \text{ where } x \in \varepsilon\mathbb{Z}^d, \\ \Gamma_\varepsilon &:= \{x \in \varepsilon\mathbb{Z}^d \mid R_x^\varepsilon \subset \Lambda_{n+1}\},\end{aligned}$$

and

$$W_\varepsilon := \begin{cases} \{\{x, y\} \mid x \neq y \text{ in } \Gamma_\varepsilon, g(|x - y|) > 0\} & \text{for the RC model,} \\ \Gamma_\varepsilon & \text{for the MA model.} \end{cases} \quad (4.13)$$

We then consider the product space $\Omega_\varepsilon := \{0, 1\}^{\Gamma_\varepsilon} \times \mathbb{R}^{W_\varepsilon}$ and write $(\eta^\varepsilon, \sigma^\varepsilon)$ for a generic element of Ω_ε . We endow Ω_ε with the product probability measure $\mathbb{P}_\lambda^{(\varepsilon)}$ making η_x^ε , as x varies in Γ_ε , a Bernoulli random variable with parameter

$$\mathbb{P}_\lambda^{(\varepsilon)}(\eta_x^\varepsilon = 1) = p_\lambda(\varepsilon) := \frac{\lambda\varepsilon^d}{1 + \lambda\varepsilon^d}, \quad (4.14)$$

and making σ_w^ε , as w varies in W_ε , a random variable with uniform distribution on $[0, 1]$ when considering the RC model, and with distribution ν when considering the MA model. To $(\eta^\varepsilon, \sigma^\varepsilon) \in \Omega_\varepsilon$ we associate the graph $G_\varepsilon = (V_\varepsilon, E_\varepsilon)$ built as follows. We set

$$V_\varepsilon := \{x \in \Gamma_\varepsilon : \eta_x^\varepsilon = 1\}.$$

In the RC model we take

$$E_\varepsilon := \{\{x, y\} : x \neq y \text{ in } V_\varepsilon, x \prec_{\text{lex}} y, \sigma_{x,y}^\varepsilon \leq g(|x - y|)\}$$

and in the MA model we take

$$E_\varepsilon := \{\{x, y\} : x \neq y \text{ in } V_\varepsilon, |x - y| + |\sigma_x^\varepsilon| + |\sigma_y^\varepsilon| + |\sigma_x^\varepsilon - \sigma_y^\varepsilon| \leq \zeta\}.$$

Given an event A concerning the graph G_ε , we define $\text{Piv}(A)$ as the family of sites of Γ_ε which are pivotal for the event A . More precisely, given a configuration $(\eta^\varepsilon, \sigma^\varepsilon)$ in Ω_ε and a site $x \in \Gamma_\varepsilon$, we say that x is pivotal for A if

$$\mathbb{1}_A(\eta^\varepsilon, \sigma^\varepsilon) \neq \mathbb{1}_A(\eta^{\varepsilon,x}, \sigma^\varepsilon),$$

where $\eta^{\varepsilon,x}$ is obtained from η^ε by replacing η_x^ε with $1 - \eta_x^\varepsilon$. We point out that the event $\{x \in \text{Piv}(A)\}$ and the random variable η_x^ε (under $\mathbb{P}_\lambda^{(\varepsilon)}$) are independent.

In what follows, we write $\mathbb{E}_\lambda^{(\varepsilon)}$ for the expectation associated to $\mathbb{P}_\lambda^{(\varepsilon)}$ and (recall Definition 4.1.2) we set

$$\tilde{\theta}_k^{(\varepsilon)}(\lambda) := \mathbb{P}_\lambda^{(\varepsilon)}(0 \leftrightarrow S_k \mid \eta_0^\varepsilon = 1), \quad \theta_k^{(\varepsilon)}(\lambda) := \mathbb{P}_\lambda^{(\varepsilon)}(0 \leftrightarrow S_k).$$

Warning 4.3.3. *Above, and in what follows, we adopt the convention that, when considering $\mathbb{P}_\lambda^{(\varepsilon)}$ or the associated expectation $\mathbb{E}_\lambda^{(\varepsilon)}$, graphical statements as “ $0 \leftrightarrow S_k$ ” refer to the random graph G_ε , if not stated otherwise.*

4.3 Outline of the proof of Theorem 1

The following result allows to approximate the functions in (4.10) and their derivatives by their discretized versions:

Proposition 4.3.1. *For any $n \geq 1$ and for all $k = 0, 1, \dots, n$ it holds*

$$\tilde{\theta}_k(\lambda) = \lim_{\varepsilon \downarrow 0} \tilde{\theta}_k^{(\varepsilon)}(\lambda), \quad (4.15)$$

$$\tilde{\psi}'_n(\lambda) = \lim_{\varepsilon \downarrow 0} \mathbb{E}_\lambda^{(\varepsilon)}[|\text{Piv}(0 \leftrightarrow S_n)|]. \quad (4.16)$$

In particular, it holds $\tilde{\psi}_k(\lambda) = \lambda \lim_{\varepsilon \downarrow 0} \tilde{\theta}_k^{(\varepsilon)}(\lambda)$.

The last statement in Proposition 4.3.1 is an immediate consequence of (4.15). The proof of (4.15) is given in Section 4.6, while the proof of (4.16) is given in Section 4.7.

4.3.3 A crucial inequality on $\theta_n^{(\varepsilon)}(\lambda)$

As explained in [4], due to the phase transition (4.5), to prove Theorem 1 it is enough to show that given $\delta \in (0, 1)$ there exists a positive constant $c_0 = c_0(\delta)$ such that for each $n \geq 1$

$$\tilde{\psi}_n(\lambda) \leq c_0 \frac{\sum_{k=0}^{n-1} \tilde{\psi}_k(\lambda)}{n} \tilde{\psi}'_n(\lambda), \quad \forall \lambda \in [\delta, \delta^{-1}]. \quad (4.17)$$

Indeed, since the functions $\lambda \mapsto \tilde{\psi}_k(\lambda)$ are increasing in λ and converging as $k \rightarrow \infty$, due to [4, Lemma 3] applied to the functions $f_n(\lambda) := c_0 \tilde{\psi}_n(\lambda)$, (4.17) implies that there exists $\lambda_* \in [\delta, \delta^{-1}]$ fulfilling the following property for any $\lambda \in [\delta, \delta^{-1}]$:

$$\begin{cases} \lambda \tilde{\theta}_n(\lambda) \leq M e^{-cn} & \text{if } \lambda < \lambda_* \text{ and } n \in \mathbb{N}, \\ \lambda \tilde{\theta}(\lambda) \geq C(\lambda - \lambda_*) & \text{if } \lambda > \lambda_*, \end{cases} \quad (4.18)$$

where $M = M(\delta) > 0$, $C = C(\delta) > 0$, $c = c(\lambda, \delta) > 0$ and $\tilde{\theta}(\lambda) = \lim_{n \rightarrow \infty} \tilde{\theta}_n(\lambda) = \mathbb{P}_{0, \lambda}(0 \leftrightarrow \infty)$. By taking δ small to have $\lambda_c \in [\delta, \delta^{-1}]$, as a byproduct of (4.5) and (4.18) we get the identity $\lambda_* = \lambda_c$ and the thesis of Theorem 1.

Due to Proposition 4.3.1, we have (4.17) if we prove that, given $\delta \in (0, 1)$, there exists a positive constant $c = c(\delta)$ such that

$$\tilde{\theta}_n^{(\varepsilon)}(\lambda) \leq o(1) + c \frac{\sum_{k=0}^{n-1} \tilde{\theta}_k^{(\varepsilon)}(\lambda)}{n} \mathbb{E}_\lambda^{(\varepsilon)}[|\text{Piv}(0 \leftrightarrow S_n)|] \quad (4.19)$$

for any $\lambda \in [\delta, \delta^{-1}]$ and $n \geq 1$, where the term $o(1)$ goes to zero uniformly in $\lambda \in [\delta, \delta^{-1}]$ as $\varepsilon \downarrow 0$. Since the event $\{0 \leftrightarrow S_k\}$ implies that $\eta_0^\varepsilon = 1$ and since $p_\lambda(\varepsilon) = O(\varepsilon^d)$ uniformly in $\lambda \in [\delta, \delta^{-1}]$, (4.19) is proved whenever we show the following proposition containing the crucial inequality on $\theta_n^{(\varepsilon)}(\lambda)$:

Proposition 4.3.2. *Given $\delta \in (0, 1)$, there exists a positive constant $c = c(\delta)$ such that*

$$\theta_n^{(\varepsilon)}(\lambda) \leq o(\varepsilon^d) + c \frac{\sum_{k=0}^{n-1} \theta_k^{(\varepsilon)}(\lambda)}{n} \mathbb{E}_\lambda^{(\varepsilon)}[|\text{Piv}(0 \leftrightarrow S_n)|] \quad (4.20)$$

for any $\lambda \in [\delta, \delta^{-1}]$ and $n \geq 1$, where $o(\varepsilon^d)/\varepsilon^d$ goes to zero uniformly in $\lambda \in [\delta, \delta^{-1}]$ as $\varepsilon \downarrow 0$.

4.3.4 Proof of Proposition 4.3.2 by the OSSS inequality

It is possible to derive (4.20) by applying the OSSS inequality for product probability spaces (cf. [11, Theorem 3.1], [4, Remark 5]). To recall it and fix the notation in our context, we first introduce the index set I_ε as the disjoint union

$$I_\varepsilon := \Gamma_\varepsilon \sqcup W_\varepsilon.$$

Since in the MA model $W_\varepsilon = \Gamma_\varepsilon$, given $x \in \Gamma_\varepsilon$ we write \dot{x} for the site x thought as element of W_ε inside I_ε . More precisely, for the MA model it is convenient to slightly change our notation and set $W_\varepsilon := \{\dot{x} : x \in \Gamma_\varepsilon\}$, thus making W_ε and Γ_ε disjoint. We will keep the notation σ_x^ε , instead of $\sigma_{\dot{x}}^\varepsilon$, since no confusion arises. To have a uniform notation for random variables, given $i \in I_\varepsilon$ we set

$$\gamma_i^\varepsilon := \begin{cases} \eta_i^\varepsilon & \text{if } i \in \Gamma_\varepsilon, \\ \sigma_i^\varepsilon & \text{if } i \in W_\varepsilon. \end{cases}$$

By construction, $\gamma^\varepsilon = (\gamma_i^\varepsilon : i \in I_\varepsilon)$ is a family of independent random variables with law $\mathbb{P}_\lambda^{(\varepsilon)}$.

We consider an algorithm T to establish if the event $\{0 \leftrightarrow S_n\}$ takes place in G_ε , having input the values γ_i^ε 's. At the beginning the algorithm does not reveal (read) all the values γ_i^ε 's, but it reveals some of them during the execution. The OSSS inequality (cf. [11, Theorem 3.1], [4, Remark 5]) then reads

$$\text{Var}_\varepsilon(\mathbb{1}_{\{0 \leftrightarrow S_n\}}) \leq \sum_{i \in I_\varepsilon} \delta_i^\varepsilon(T) \text{Inf}_i^\varepsilon(0 \leftrightarrow S_n), \quad (4.21)$$

where the above variance refers to $\mathbb{P}_\lambda^{(\varepsilon)}$, $\delta_i^\varepsilon(T)$ and $\text{Inf}_i^\varepsilon(0 \leftrightarrow S_n)$ are respectively the *revelment* and the *influence* of γ_i^ε . More precisely, one sets

$$\begin{aligned} \delta_i^\varepsilon(T) &:= \mathbb{P}_\lambda^{(\varepsilon)}(T \text{ reveals the value of } \gamma_i^\varepsilon), \\ \text{Inf}_i^\varepsilon(0 \leftrightarrow S_n) &:= \mathbb{P}_\lambda^{(\varepsilon)}(\mathbb{1}_{\{0 \leftrightarrow S_n\}}(\gamma^\varepsilon) \neq \mathbb{1}_{\{0 \leftrightarrow S_n\}}(\gamma^{\varepsilon, i})), \end{aligned}$$

where $\gamma^{\varepsilon, i} = (\gamma_j^{\varepsilon, i} : j \in I_\varepsilon)$ appearing in the second identity is characterized by the following requirements: (a) $\gamma_j^{\varepsilon, i} := \gamma_j^\varepsilon$ for all $j \neq i$, (b) $\gamma_i^{\varepsilon, i}$ has the same distribution of γ_i^ε , (c) $\gamma_i^{\varepsilon, i}$ is independent of the family γ^ε (with some abuse, we have kept the notation $\mathbb{P}_\lambda^{(\varepsilon)}$ for the joint law).

Since $\text{Var}_\varepsilon(\mathbb{1}_{\{0 \leftrightarrow S_n\}}) = \theta_n^{(\varepsilon)}(\lambda)(1 - \theta_n^{(\varepsilon)}(\lambda))$, (4.21) implies for any $\varepsilon_0 > 0$ that

$$\theta_n^{(\varepsilon)}(\lambda) \leq c \sum_{i \in I_\varepsilon} \delta_i^\varepsilon(T) \text{Inf}_i^\varepsilon(0 \leftrightarrow S_n) \quad \forall \varepsilon < \varepsilon_0, \quad (4.22)$$

where $c := \sup_{\lambda \in [\delta, \delta^{-1}]} \sup_{\varepsilon \leq \varepsilon_0} (1 - \theta_1^{(\varepsilon)}(\lambda))^{-1}$ (note that $\theta_n^{(\varepsilon)}(\lambda) \leq \theta_1^{(\varepsilon)}(\lambda)$ for $n \geq 1$). As $\theta_1^{(\varepsilon)}(\lambda) \leq \mathbb{P}_\lambda^{(\varepsilon)}(\eta_0^\varepsilon = 1) \approx \lambda \varepsilon^d$, by taking a suitable $\varepsilon_0 = \varepsilon_0(\delta)$, we get that c is strictly positive and that c depends only on δ .

Similarly to [4], in order to derive (4.20) from (4.22), for each $k = 1, \dots, n$ we construct an algorithm T_k to determine if the event $\{0 \leftrightarrow S_n\}$ occurs such that the following Lemmas 4.3.3 and 4.3.4 are valid:

4.4 The algorithm T_k

Lemma 4.3.3. *For any $k \in \{1, 2, \dots, n\}$ given $\delta \in (0, 1)$ it holds*

$$\sum_{i \in W_\varepsilon} \delta_i^\varepsilon(T_k) \text{Inf}_i^\varepsilon(0 \leftrightarrow S_n) = o(\varepsilon^d), \quad (4.23)$$

where $o(\varepsilon^d)/\varepsilon^d$ goes to zero uniformly in $\lambda \in [\delta, \delta^{-1}]$ as $\varepsilon \downarrow 0$.

Lemma 4.3.4. *Given $\delta \in (0, 1)$ there exists $c = c(\delta) > 0$ such that, for any $\lambda \in [\delta, \delta^{-1}]$ and any $n \geq 1$, it holds*

$$\frac{1}{n} \sum_{k=1}^n \delta_k^\varepsilon(T_k) \leq c \varepsilon^{-d} \frac{1}{n} \sum_{a=0}^{n-1} \theta_a^{(\varepsilon)}(\lambda) \quad \forall i \in \Gamma_\varepsilon. \quad (4.24)$$

The algorithm T_k is described in Section 4.4, while Lemmas 4.3.3 and 4.3.4 are proved in Section 4.5.

From (4.22), by averaging among k , we have

$$\theta_n^{(\varepsilon)}(\lambda) \leq c \sum_{i \in I_\varepsilon} \left[\frac{1}{n} \sum_{k=1}^n \delta_k^{(\varepsilon)}(T_k) \right] \text{Inf}_i^\varepsilon(0 \leftrightarrow S_n) \quad (4.25)$$

for any $\varepsilon \leq \varepsilon_0(\delta)$ and for $c = c(\delta)$. By combining (4.25) with Lemmas 4.3.3 and 4.3.4 we get

$$\theta_n^{(\varepsilon)}(\lambda) \leq o(\varepsilon^d) + c \varepsilon^{-d} \frac{\sum_{k=0}^{n-1} \theta_k^{(\varepsilon)}(\lambda)}{n} \sum_{i \in \Gamma_\varepsilon} \text{Inf}_i^\varepsilon(0 \leftrightarrow S_n) \quad (4.26)$$

for any $\varepsilon \leq \varepsilon_0(\delta)$ and for $c = c(\delta)$.

Hence the crucial inequality (4.20) in Proposition 4.3.2 follows from (4.26) and the following lemma:

Lemma 4.3.5. *There exists $c = c(\delta) > 0$ such that, for each event $A \subset \Omega_\varepsilon$ which is increasing in the random variables η_i^ε 's, it holds*

$$\text{Inf}_i^\varepsilon(A) \leq c \varepsilon^d \mathbb{P}_\lambda^{(\varepsilon)}(i \in \text{Piv}(A)) \quad \forall i \in \Gamma_\varepsilon, \forall \lambda \in [\delta, \delta^{-1}].$$

The proof of the above lemma is given in Section 4.5. This concludes the proof of Proposition 4.3.2.

4.4 The algorithm T_k

Fixed $k \in \{1, \dots, n\}$ we are interested in constructing an algorithm T_k that determines if the event $\{0 \leftrightarrow S_n\}$ takes place in G_ε . We introduce the sets

$$L_\varepsilon = \{\{x, y\} : x \neq y \text{ in } \Gamma_\varepsilon, f(|x - y|) > 0\},$$

$$H_\varepsilon^k = \{\{x, y\} \in L_\varepsilon : \overline{xy} \text{ intersects } S_k\},$$

where $f := g$ in the RC model, $f := h$ in the MA model and \overline{xy} denotes the segment in \mathbb{R}^d with extremes x, y . For simplicity, we set $xy := \{x, y\}$ with the convention that $x \prec_{\text{lex}} y$.

We fix an ordering in L_ε such that the elements of H_ε^k precede the elements of $L_\varepsilon \setminus H_\varepsilon^k$. Finally, we introduce the random variables $(U_{x,y}^\varepsilon : xy \in L_\varepsilon)$ defined on $(\Omega_\varepsilon, \mathbb{P}_\lambda^{(\varepsilon)})$ as follows:

$$U_{x,y}^\varepsilon := \begin{cases} \mathbb{1}(\sigma_{x,y}^\varepsilon \leq g(|x-y|)) & \text{in the RC model,} \\ \mathbb{1}(|x-y| + |\sigma_x^\varepsilon| + |\sigma_y^\varepsilon| + |\sigma_x^\varepsilon - \sigma_y^\varepsilon| \leq \zeta) & \text{in the MA model.} \end{cases}$$

Note that, by definition of the edge set E_ε of the graph G_ε , we have that $\{x, y\} \in E_\varepsilon$ with $x \prec_{\text{lex}} y$ if and only if $xy \in L_\varepsilon$ and $\eta_x^\varepsilon = \eta_y^\varepsilon = U_{x,y}^\varepsilon = 1$.

The algorithm is organised by *meta-steps* parameterised by the elements of L_ε . $t(r)$ will be the number of revealed variables up to the r^{th} meta-step included. At each meta-step the algorithm will provide two sets F_r, V_r : V_r is roughly the set of vertices connected to some edge in $E_\varepsilon \cap H_\varepsilon^k$ discovered up to the r^{th} meta-step, while F_r is roughly the set of edges connected to some edge in $E_\varepsilon \cap H_\varepsilon^k$ discovered up to the r^{th} meta-step. We recall that E_ε denotes the set of edges of the graph G_ε .

Beginning of the algorithm

First meta-step. Let xy be the first element of H_ε^k . Reveal the random variables η_x^ε and η_y^ε . Set $e_1 := x$, $e_2 := y$.

- If $\eta_x^\varepsilon \eta_y^\varepsilon = 0$, then set $(F_1, V_1) := (\emptyset, \emptyset)$ and $t(1) = 2$, thus completing the first-meta step in this case.

- If $\eta_x^\varepsilon \eta_y^\varepsilon = 1$, then in the RC model reveal the random variable $\sigma_{x,y}^\varepsilon$ and set $e_3 := xy$, $t(1) := 3$, while in the MA model reveal the random variables $\sigma_x^\varepsilon, \sigma_y^\varepsilon$ and set $e_3 := \dot{x}$, $e_4 := \dot{y}$, $t(1) := 4$. In both cases set

$$(F_1, V_1) := \begin{cases} (\{xy\}, \{x, y\}) & \text{if } U_{x,y}^\varepsilon = 1, \\ (\emptyset, \emptyset) & \text{otherwise,} \end{cases} \quad (4.27)$$

thus completing the first meta-step in this case.

* End of the first meta-step *

Generic r^{th} meta-step for $r \geq 2$. Distinguish two cases. If $r \leq |H_\varepsilon^k|$, then let xy be the r^{th} element of H_ε^k . If $r > |H_\varepsilon^k|$, look for the minimum edge xy in $L_\varepsilon \setminus H_\varepsilon^k$ such that $\{x, y\} \cap V_{r-1} \neq \emptyset$. If such an edge does not exist, then set $R_{\text{end}} := r - 1$ and $T_{\text{end}} := t(r - 1)$, all the generic meta-steps are completed hence move to the final step.

Set $N = 0$ (N will play the role of counter).

- If η_x^ε has not been revealed yet, do the following: reveal the random variable η_x^ε , increase N by $+1$, and set $e_{t(r-1)+N} := x$.

- If η_y^ε has not been revealed yet, then reveal the random variable η_y^ε , increase N by $+1$ and set $e_{t(r-1)+N} := y$.

- If $\eta_x^\varepsilon \eta_y^\varepsilon = 0$, then set $(F_r, V_r) := (F_{r-1}, V_{r-1})$ and $t(r) := t(r - 1) + N$, thus completing the r^{th} meta-step in this case.

- If $\eta_x^\varepsilon \eta_y^\varepsilon = 1$, then:

4.5 Proof of Lemmas 4.3.3, 4.3.4 and 4.3.5

- ★ In the RC model reveal the random variable $\sigma_{x,y}^\varepsilon$, increase N by $+1$, set $e_{t(r-1)+N} := xy$;
- ★ In the MA model, if σ_x^ε has not been revealed yet, then reveal it, increase N by $+1$, set $e_{t(r-1)+N} := \dot{x}$. In addition, if σ_y^ε has not been revealed yet, then reveal it, increase N by $+1$, set $e_{t(r-1)+N} := \dot{y}$.

In both the above ★-cases set $t(r) := t(r-1) + N$,

$$(F_r, V_r) := \begin{cases} (F_r \cup \{xy\}, V_r \cup \{x, y\}) & \text{if } U_{x,y}^\varepsilon = 1, \\ (F_{r-1}, V_{r-1}) & \text{otherwise,} \end{cases}$$

thus completing the r^{th} meta-step.

Final step. If $0 \in V_{R_{\text{end}}}$ and there exists a path from 0 to $V_{R_{\text{end}}} \setminus (-n, n)^d$ inside the graph $(V_{R_{\text{end}}}, F_{R_{\text{end}}})$ then give as output “ $0 \leftrightarrow S_n$ ”, otherwise give as output “ $0 \not\leftrightarrow S_n$ ”.

End of the algorithm

We conclude with some comments on the algorithm.

First, since L_ε is finite, the algorithm always stops. Moreover we note that, when the algorithm has to check if $U_{x,y}^\varepsilon = 1$, this is possible using only the revealed random variables.

By construction, in the algorithm $T_k, V_{R_{\text{end}}} := \{x \in \Gamma_\varepsilon : x \leftrightarrow S_k\}$. Moreover, $F_{R_{\text{end}}}$ is the set of edges belonging to some path in G_ε for which there is an edge $\{x, y\}$ such that the segment \overline{xy} intersects S_k (we shortly say that the paths intersect S_k). If $0 \leftrightarrow S_n$ then there must be a path in G_ε from 0 to some point x in $\Gamma_\varepsilon \setminus (-n, n)^d$, and this path must intersect S_k . As a consequence, if $0 \leftrightarrow S_n$ then there exists a path from 0 to $V_{R_{\text{end}}} \setminus (-n, n)^d$ inside the graph $(V_{R_{\text{end}}}, F_{R_{\text{end}}})$. The other implication is trivially fulfilled, hence the output of the algorithm is correct.

Finally, we point out that the revealed random variables are, in chronological order, the ones associated to the indexes $e_1, e_2, \dots, \dots, e_{T_{\text{end}}}$ (in the cases $e_i = x$, $e_i = \dot{x}$ and $e_i = xy$, the associated random variables are given by η_x^ε , σ_x^ε and $\sigma_{x,y}^\varepsilon$, respectively).

4.5 Proof of Lemmas 4.3.3, 4.3.4 and 4.3.5

In this section we prove Lemmas 4.3.3, 4.3.4 and 4.3.5 which enter in the proof of Proposition 4.3.2 as discussed in Section 4.3.4.

To simplify the notation, given $\alpha \in \mathbb{R}$, we will denote by $O(\varepsilon^\alpha)$ any quantity which can be bounded from above by $C\varepsilon^\alpha$, where the constant C can depend on δ but not on the particular value $\lambda \in [\delta, \delta^{-1}]$. Similarly, we denote by $o(1)$ any quantity which can be bounded from above by $Cf(\varepsilon)$, where $\lim_{\varepsilon \downarrow 0} f(\varepsilon) = 0$, and both f and C can depend on δ but not on the particular value $\lambda \in [\delta, \delta^{-1}]$. We point out that the above quantities could depend on n .

4.5.1 Proof of Lemma 4.3.3

We consider first the RC model. Recall that in this case $W_\varepsilon = L_\varepsilon$ (cf. (4.13)). Let $i = \{x, y\} \in L_\varepsilon$ with $x \prec_{\text{lex}} y$. If $\sigma_{x,y}^\varepsilon$ is revealed by the algorithm, then it must be $\eta_x^\varepsilon = \eta_y^\varepsilon = 1$. Hence we have $\delta_i^\varepsilon(T_k) \leq \mathbb{P}_\lambda^{(\varepsilon)}(\eta_x^\varepsilon = \eta_y^\varepsilon = 1) = O(\varepsilon^{2d})$. On the other hand, by definition,

$$\text{Inf}_i^\varepsilon(0 \leftrightarrow S_n) = \mathbb{P}_\lambda^{(\varepsilon)}(\mathbf{1}_A(\gamma^\varepsilon) \neq \mathbf{1}_A(\gamma^{\varepsilon,i})) \text{ with } A := \{0 \leftrightarrow S_n\}. \quad (4.28)$$

If $\mathbf{1}_A(\gamma^\varepsilon) \neq \mathbf{1}_A(\gamma^{\varepsilon,i})$ then it must be $\eta_0^\varepsilon = 1, \eta_x^\varepsilon = 1, \eta_y^\varepsilon = 1$. As a consequence, we get that $\text{Inf}_i^\varepsilon(0 \leftrightarrow S_n) \leq \mathbb{P}_\lambda^{(\varepsilon)}(\eta_0^\varepsilon = 1, \eta_x^\varepsilon = 1, \eta_y^\varepsilon = 1)$. The last probability is $O(\varepsilon^{2d})$ if the edge $\{x, y\}$ contains the origin (and there are $O(\varepsilon^{-d})$ of such edges in W_ε), while it is $O(\varepsilon^{3d})$ if the edge $\{x, y\}$ does not contain the origin (and there are $O(\varepsilon^{-2d})$ of such edges in W_ε). Using that $\delta_i^\varepsilon(T_k) = O(\varepsilon^{2d})$, we get (4.23).

We now move to the MA model. Let $i = \dot{x} \in W_\varepsilon$. If σ_x^ε is revealed by the algorithm, then it must be $\eta_x^\varepsilon = 1$. Hence, $\delta_i^\varepsilon(T_k) = O(\varepsilon^d)$. On the other hand, by (4.28), if $\mathbf{1}_A(\gamma^\varepsilon) \neq \mathbf{1}_A(\gamma^{\varepsilon,i})$ then it must be $\eta_0^\varepsilon = \eta_x^\varepsilon = 1$. Hence, $\text{Inf}_i^\varepsilon(0 \leftrightarrow S_n) = O(\varepsilon^d)$ if $x = 0$ and $\text{Inf}_i^\varepsilon(0 \leftrightarrow S_n) = O(\varepsilon^{2d})$ if $x \neq 0$. Since $|W_\varepsilon| = O(\varepsilon^{-d})$, we get (4.23), thus concluding the proof of Lemma 4.3.3.

4.5.2 Proof of Lemma 4.3.4

In what follows, constants $c_*(d), c(d), \dots$ are positive constants depending only on the dimension d . We also write $i \in H_\varepsilon^k$ if the site i belongs to some edge in H_ε^k . Since the edges in H_ε^k have length smaller than 1, if $i \in H_\varepsilon^k$ then $d_e(i, S_k) < 1$, where $d_e(\cdot, \cdot)$ denotes the Euclidean distance. This implies that $|\{k \in \mathbb{N} : i \in H_\varepsilon^k\}| \leq 2$.

We observe that, when $i \notin H_\varepsilon^k$,

$$\{\eta_i^\varepsilon \text{ is revealed by } T_k\} \subset \{i \leftrightarrow S_k\} \cup \{\exists j \in \Gamma_\varepsilon \setminus \{i\} : |i - j| < 1, j \leftrightarrow S_k\}.$$

Hence we can bound

$$\delta_i^\varepsilon(T_k) \mathbf{1}(i \notin H_\varepsilon^k) \leq \sum_{j \in \Gamma_\varepsilon : |i-j| \leq 1} \mathbb{P}_\lambda^{(\varepsilon)}(j \leftrightarrow S_k). \quad (4.29)$$

By translation invariance we have $\mathbb{P}_\lambda^{(\varepsilon)}(j \leftrightarrow S_k) \leq \theta_{d(j, S_k)}^{(\varepsilon)}(\lambda)$, where $d(j, S_k)$ denotes the distance in uniform norm between j and S_k . Note that $d(j, S_k) \leq n$. Hence we can write

$$\delta_i^\varepsilon(T_k) \mathbf{1}(i \notin H_\varepsilon^k) \leq \sum_{j \in \Gamma_\varepsilon : |i-j| \leq 1} \mathbb{P}_\lambda^{(\varepsilon)}(j \leftrightarrow S_k) \leq \sum_{j \in \Gamma_\varepsilon : |i-j| \leq 1} \theta_{d(j, S_k)}^{(\varepsilon)}(\lambda).$$

If the integer $a \geq 0$ satisfies $a \leq d(j, S_k) \leq a + 1$, then we can bound $\theta_{d(j, S_k)}^{(\varepsilon)}(\lambda) \leq \theta_a^{(\varepsilon)}(\lambda)$. Hence we can write

$$\delta_i^\varepsilon(T_k) \mathbf{1}(i \notin H_\varepsilon^k) \leq \sum_{a=0}^{n-1} \theta_a^{(\varepsilon)}(\lambda) |\{j \in \Gamma_\varepsilon : |i-j| \leq 1, a \leq d(j, S_k) \leq a+1\}|. \quad (4.30)$$

4.6 Proof of (4.15) in Proposition 4.3.1

Let us now consider, for a fixed a ,

$$\sum_{k=1}^n |\{j \in \Gamma_\varepsilon : |i - j| \leq 1, a \leq d(j, S_k) \leq a + 1\}|. \quad (4.31)$$

If $|i - j| \leq 1$ and $a \leq d(j, S_k) \leq a + 1$, then it must be $a - c_* \leq d(i, S_k) \leq a + c_*$, for some constant $c_* = c_*(d)$. Since k varies among the integers, there are at most $c(d)$ values of k for which $a - c_* \leq d(i, S_k) \leq a + c_*$. For the other values of k the associated addendum in (5.29) is simply zero. We conclude that the sum in (5.29) is bounded by $c(d)\varepsilon^{-d}$. Therefore, averaging (4.30) among k , we get

$$\frac{1}{n} \sum_{k=1}^n \delta_i^\varepsilon(T_k) \mathbf{1}(i \notin H_\varepsilon^k) \leq c(d)\varepsilon^{-d} \frac{1}{n} \sum_{a=0}^{n-1} \theta_a^{(\varepsilon)}(\lambda). \quad (4.32)$$

On the other hand, by the observation made at the beginning of the proof, we can bound $\sum_{k=1}^n \delta_i^\varepsilon(T_k) \mathbf{1}(i \in H_\varepsilon^k) \leq 2$, while

$$\varepsilon^{-d} \sum_{a=0}^{n-1} \theta_a^{(\varepsilon)}(\lambda) \geq \varepsilon^{-d} \theta_0^{(\varepsilon)}(\lambda) = \varepsilon^{-d} \mathbb{P}_\lambda^{(\varepsilon)}(0 \leftrightarrow S_0) = \varepsilon^{-d} \mathbb{P}_\lambda^{(\varepsilon)}(\eta_0^\varepsilon = 1) = \frac{\lambda}{1 + \lambda \varepsilon^d}. \quad (4.33)$$

We therefore conclude that

$$\frac{1}{n} \sum_{k=1}^n \delta_i^\varepsilon(T_k) \mathbf{1}(i \in H_\varepsilon^k) \leq c(\delta)\varepsilon^{-d} \frac{1}{n} \sum_{a=0}^{n-1} \theta_a^{(\varepsilon)}(\lambda). \quad (4.34)$$

The thesis then follows from (4.32) and (4.34).

4.5.3 Proof of Lemma 4.3.5

By symmetry we have

$$\begin{aligned} \text{Inf}_i^\varepsilon(A) &= 2\mathbb{P}_\lambda^{(\varepsilon)}(\mathbf{1}_A(\gamma^\varepsilon) \neq \mathbf{1}_A(\gamma^{\varepsilon,i}), \gamma_i^\varepsilon = 1, \gamma_i^{\varepsilon,i} = 0) \\ &= 2\mathbb{P}_\lambda^{(\varepsilon)}(\mathbf{1}_A(\gamma^\varepsilon) \neq \mathbf{1}_A(\hat{\gamma}^\varepsilon), \gamma_i^\varepsilon = 1, \gamma_i^{\varepsilon,i} = 0), \end{aligned} \quad (4.35)$$

where the configuration $\hat{\gamma}^\varepsilon$ is obtained from γ^ε by changing the value of $\gamma_i^\varepsilon = \eta_i^\varepsilon$. The inequality $\mathbf{1}_A(\gamma^\varepsilon) \neq \mathbf{1}_A(\hat{\gamma}^\varepsilon)$ is equivalent to the fact that i is pivotal for the event A and the configuration γ^ε . Moreover, this event is independent from $\gamma_i^\varepsilon, \gamma_i^{\varepsilon,i}$. Hence (4.35) implies that

$$\text{Inf}_i^\varepsilon(A) \leq 2\mathbb{P}_\lambda^{(\varepsilon)}(i \in \text{Piv}(A), \eta_i^\varepsilon = 1) \leq 2\mathbb{P}_\lambda^{(\varepsilon)}(i \in \text{Piv}(A))p_\lambda(\varepsilon).$$

This concludes the proof of Lemma 4.3.5.

4.6 Proof of (4.15) in Proposition 4.3.1

In the proof below, constants $c, c_1, c_2 \dots$ are understood as positive and ε -independent and they can change from line to line. To simplify the notation, given $\alpha \in \mathbb{R}$, we will denote by $O(\varepsilon^\alpha)$ any quantity which can be bounded from above by $C\varepsilon^\alpha$, where the

constant C can depend on λ . Similarly, we denote by $o(1)$ any quantity which can be bounded from above by $Cf(\varepsilon)$, where $\lim_{\varepsilon \downarrow 0} f(\varepsilon) = 0$, and both f and C can depend on λ . All the above quantities can depend also on n , which is fixed once and for all.

Recall that $n \geq 1$. To simplify the notation we take $k = n$ (the general case is similar). Recall the notation introduced in Section 4.3.1. We use the standard convention to identify an element ξ of \mathcal{N} with the atomic measure $\sum_{x \in \xi} \delta_x$, which will be denoted again by ξ . In particular, given $U \subset \mathbb{R}^d$, $\xi(U)$ equals $|\xi \cap U|$. In addition, given $\xi \in \mathcal{N}$ and $x \in \mathbb{R}^d$, we define the translation $\tau_x \xi$ as the new set $\xi - x$.

We define the events

$$\begin{aligned} A_\varepsilon &:= \{ \xi \in \mathcal{N} : \xi(R_x^\varepsilon) \in \{0, 1\} \quad \forall x \in \Gamma_\varepsilon \}, \\ B_\varepsilon &:= \{ \xi \in \mathcal{N} : \xi(R_0^\varepsilon) = 1 \}. \end{aligned}$$

If $\xi(R_x^\varepsilon) = 1$, then we define \bar{x} as the unique point of $\xi \cap R_x^\varepsilon$. On the space \mathcal{N} we define the functions

$$\varphi_x^\varepsilon = \mathbf{1}(\xi(R_x^\varepsilon) = 1), \quad x \in \Gamma_\varepsilon. \quad (4.36)$$

Recall Warning 4.3.2 in Section 4.3.2.

Lemma 4.6.1. *It holds*

$$\tilde{\theta}_n(\lambda) = \mathbb{P}_{0,\lambda}(0 \leftrightarrow S_n) = \lim_{\varepsilon \downarrow 0} \mathbb{P}_\lambda(\bar{0} \leftrightarrow S_n \mid B_\varepsilon). \quad (4.37)$$

Proof. We use the properties of the Campbell measure and Palm distribution stated in [2, Thm. 12.2.II and Eq. (12.2.4)]. We apply [2, Eq. (12.2.4)] with

$$g(x, \xi) := \mathbf{1}(x \in R_0^\varepsilon) \int_{\Sigma} P(d\sigma) \mathbf{1}(0 \leftrightarrow S_n \text{ in } \mathcal{G}(\xi, \sigma))$$

(see the notation of Section 4.3.1) and get

$$\begin{aligned} \lambda \varepsilon^d \mathbb{P}_{0,\lambda}(0 \leftrightarrow S_n) &= \lambda E_{0,\lambda} \left[\int_{\mathbb{R}^d} dx g(x, \xi) \right] = E_\lambda \left[\int_{\mathbb{R}^d} \xi(dx) g(x, \tau_x \xi) \right] \\ &= \mathbb{E}_\lambda \left[\int_{R_0^\varepsilon} \xi(dx) \mathbf{1}(x \leftrightarrow S_n(x)) \right], \end{aligned} \quad (4.38)$$

where $S_n(x) := S_n + x$. We set $N_\varepsilon := \xi(R_0^\varepsilon)$. N_ε is a Poisson random variable with parameter $\lambda \varepsilon^d$. We point out that

$$\begin{aligned} \mathbb{E}_\lambda \left[\int_{R_0^\varepsilon} \xi(dx) \mathbf{1}(x \leftrightarrow S_n(x)) \mathbf{1}(N_\varepsilon \geq 2) \right] &\leq \mathbb{E}_\lambda [N_\varepsilon \mathbf{1}(N_\varepsilon \geq 2)] \\ &= \mathbb{E}_\lambda [N_\varepsilon] - \mathbb{P}_\lambda(N_\varepsilon = 1) = \lambda \varepsilon^d (1 - e^{-\lambda \varepsilon^d}) = O(\varepsilon^{2d}). \end{aligned} \quad (4.39)$$

Moreover, we can bound

$$\begin{aligned} \mathbb{P}_\lambda(\{\bar{0} \leftrightarrow S_{n+\varepsilon}\} \cap B_\varepsilon) &\leq \mathbb{E}_\lambda \left[\int_{R_0^\varepsilon} \xi(dx) \mathbf{1}(x \leftrightarrow S_n(x)) \mathbf{1}(N_\varepsilon = 1) \right] \\ &\leq \mathbb{P}_\lambda(\{\bar{0} \leftrightarrow S_{n-\varepsilon}\} \cap B_\varepsilon). \end{aligned} \quad (4.40)$$

4.6 Proof of (4.15) in Proposition 4.3.1

Since $\mathbb{P}_\lambda(B_\varepsilon) = \lambda\varepsilon^d(1 + o(1))$, from (4.38), (4.39) and (4.40) we conclude that

$$\mathbb{P}_{0,\lambda}(0 \leftrightarrow S_n) \geq \mathbb{P}_\lambda(\bar{0} \leftrightarrow S_{n+\varepsilon} | B_\varepsilon) + o(1), \quad (4.41)$$

$$\mathbb{P}_{0,\lambda}(0 \leftrightarrow S_n) \leq \mathbb{P}_\lambda(\bar{0} \leftrightarrow S_{n-\varepsilon} | B_\varepsilon) + o(1). \quad (4.42)$$

On the other hand, $\mathbb{P}_\lambda(\xi(\Lambda_{n+\varepsilon} \setminus \overset{\circ}{\Lambda}_{n-\varepsilon}) \geq 1) = O(\varepsilon)$. Since for ε small (as we assume from now on) the events $\{\xi(\Lambda_{n+\varepsilon} \setminus \overset{\circ}{\Lambda}_{n-\varepsilon}) \geq 1\}$ and B_ε are independent, we conclude that $\mathbb{P}_\lambda(\xi(\Lambda_{n+\varepsilon} \setminus \overset{\circ}{\Lambda}_{n-\varepsilon}) \geq 1 | B_\varepsilon) = O(\varepsilon)$. As a consequence, we have

$$\begin{aligned} \mathbb{P}_\lambda(\bar{0} \leftrightarrow S_n | B_\varepsilon) &= \mathbb{P}_\lambda(\bar{0} \leftrightarrow S_n \text{ and } \xi(\Lambda_{n+\varepsilon} \setminus \overset{\circ}{\Lambda}_{n-\varepsilon}) = 0 | B_\varepsilon) + o(1) \\ &\leq \mathbb{P}_\lambda(\bar{0} \leftrightarrow S_{n+\varepsilon} | B_\varepsilon) + o(1), \end{aligned} \quad (4.43)$$

and

$$\begin{aligned} \mathbb{P}_\lambda(\bar{0} \leftrightarrow S_{n-\varepsilon} | B_\varepsilon) &= \mathbb{P}_\lambda(\bar{0} \leftrightarrow S_{n-\varepsilon} \text{ and } \xi(\Lambda_{n+\varepsilon} \setminus \overset{\circ}{\Lambda}_{n-\varepsilon}) = 0 | B_\varepsilon) + o(1) \\ &\leq \mathbb{P}_\lambda(\bar{0} \leftrightarrow S_n | B_\varepsilon) + o(1). \end{aligned} \quad (4.44)$$

By combining (4.41) with (4.43), and (4.42) with (4.44), we get

$$\mathbb{P}_{0,\lambda}(0 \leftrightarrow S_n) = \mathbb{P}_\lambda(\bar{0} \leftrightarrow S_n | B_\varepsilon) + o(1), \quad (4.45)$$

which is equivalent to (4.37). \square

We now enlarge the probability space (Σ, P) introduced in Section 4.3.1 as follows. For the RC model the enlarged probability space is obtained from (Σ, P) by adding independent uniform random variables $\sigma_{x,y}$ indexed by the pairs (x, y) with $x \neq y$ and such that $x, y \in \Gamma_\varepsilon$ for some $\varepsilon = 1/m$, m being a positive integer. We take these additional random variables independent from the original random variables $\sigma_{(n_1, k_1), (n_2, k_2)}$ defined in (Σ, P) . We point out a slight abuse of notation, since in Section 4.3.1 we have defined $\sigma_{x,y}$ by means of (4.9) when $x, y \in \xi$. On the other hand, the probability that the realization ξ of a Poisson point process has some vertex in $\cup_{m=1}^\infty \Gamma_{1/m}$ is zero, thus implying that the notation $\sigma_{x,y}$ is not ambiguous with probability 1. For the MA model the enlarged probability space is obtained from (Σ, P) by adding i.i.d. random variables σ_x with distribution ν , indexed by the points x belonging to some Γ_ε as $\varepsilon = 1/m$ and m varies among the positive integers. Again the new random variables are independent from the ones previously defined in (Σ, P) and again the notation is not ambiguous with probability 1. To avoid new symbols, we denote by (Σ, P) the enlarged probability space and we keep the definition $\mathbb{P}_\lambda := P_\lambda \times P$, $\mathbb{P}_{0,\lambda} := P_{0,\lambda} \times P$, where now P refers to the enlarged probability space.

Given points $x \neq y$ and $x' \neq y'$ we define

$$\psi_{x,y}^{x',y'} := \begin{cases} \mathbf{1}(\sigma_{x,y} \leq g(|x' - y'|)) & \text{in the RC model,} \\ \mathbf{1}(|x' - y'| + |\sigma_x| + |\sigma_y| + |\sigma_x - \sigma_y| \leq \zeta) & \text{in the MA model.} \end{cases}$$

We now introduce a new graph $\mathcal{G}_\varepsilon = (\mathcal{V}_\varepsilon, \mathcal{E}_\varepsilon)$ which is (as the graph \mathcal{G} introduced in Section 4.3.1) a function of the pair $(\xi, \sigma) \in \mathcal{N} \times \Sigma$. We set

$$\mathcal{V}_\varepsilon := \{x \in \Gamma_\varepsilon : \xi(R_x^\varepsilon) = 1\}$$

while we define \mathcal{E}_ε as

$$\mathcal{E}_\varepsilon = \{\{x, y\} \mid x, y \in \mathcal{V}_\varepsilon, x \prec_{\text{lex}} y, \Psi_{x,y}^{x,y} = 1\}. \quad (4.46)$$

When the event A_ε (defined at the beginning of the section) takes place we define a new graph $\mathcal{G}_\varepsilon^\# = (\mathcal{V}_\varepsilon, \mathcal{E}_\varepsilon^\#)$ as function of $(\xi, \sigma) \in \mathcal{N} \times \Sigma$ by setting

$$\mathcal{E}_\varepsilon^\# = \{\{x, y\} \mid x, y \in \mathcal{V}_\varepsilon, x \prec_{\text{lex}} y, \Psi_{x,y}^{\bar{x},\bar{y}} = 1\}. \quad (4.47)$$

Similarly, when the event A_ε takes place, we define a new graph $\mathcal{G}_\varepsilon^* = (\mathcal{V}_\varepsilon, \mathcal{E}_\varepsilon^*)$ as function of $(\xi, \sigma) \in \mathcal{N} \times \Sigma$ by setting

$$\mathcal{E}_\varepsilon^* = \{\{x, y\} \mid x, y \in \mathcal{V}_\varepsilon, x \prec_{\text{lex}} y, \Psi_{x,y}^{\bar{x},\bar{y}} = 1\}. \quad (4.48)$$

We note that $\mathcal{G}_\varepsilon^*$ is the graph with vertex set \mathcal{V}_ε and with edges given by the pairs $\{x, y\}$ where x, y vary between the sites in \mathcal{V}_ε with $\{\bar{x}, \bar{y}\} \in \mathcal{E}$. Roughly, $\mathcal{G}_\varepsilon^*$ is the graph obtained from \mathcal{G} restricted to Λ_{n+1} by sliding the vertex at \bar{x} (with $x \in \Gamma_\varepsilon$) to x .

Finally we observe that

$$\begin{aligned} \mathbb{P}_\lambda(A_\varepsilon^c \cap B_\varepsilon) &= \mathbb{P}_\lambda(B_\varepsilon \cap \{\exists y \in \Gamma_\varepsilon \setminus \{0\} : \xi(R_y^c) \geq 2\}) \\ &\leq \mathbb{P}_\lambda(B_\varepsilon) \sum_{y \in \Gamma_\varepsilon \setminus \{0\}} \mathbb{P}_\lambda(\xi(R_y^c) \geq 2) = \mathbb{P}_\lambda(B_\varepsilon) O(\varepsilon^d), \end{aligned} \quad (4.49)$$

thus implying that $\mathbb{P}_\lambda(A_\varepsilon^c \mid B_\varepsilon) = O(\varepsilon^d)$.

Lemma 4.6.2. *The event $\{\bar{0} \leftrightarrow S_n \text{ in } \mathcal{G}\}$ equals the event $\{0 \leftrightarrow S_n \text{ in } \mathcal{G}_\varepsilon^*\}$ if $\xi(\Lambda_{n+\varepsilon} \setminus \overset{\circ}{\Lambda}_{n-\varepsilon}) = 0$.*

Proof. Let $\{a, b\}$ be an edge of \mathcal{G} with $\|a\|_\infty < n$ and $\|b\|_\infty \geq n$. Since $\xi(\Lambda_{n+\varepsilon} \setminus \overset{\circ}{\Lambda}_{n-\varepsilon}) = 0$ we have $\|a\|_\infty < n - \varepsilon$ and $\|b\|_\infty \geq n + \varepsilon$. On the other hand, the Euclidean distance between a and b is smaller than 1, thus implying that $\|a\|_\infty \geq n + \varepsilon - 1$ and $\|b\|_\infty < n + 1 - \varepsilon$. Suppose now that $\bar{0} \leftrightarrow S_n$ in \mathcal{G} and let $a, b \in \xi$ be such that $\bar{0} \leftrightarrow a$, $\{a, b\}$ is an edge of \mathcal{G} , $\|a\|_\infty < n$ and $\|b\|_\infty \geq n$. As already observed, $n + \varepsilon \leq \|b\|_\infty < n + 1 - \varepsilon$, thus implying that $b = \bar{z}$ for some $z \in \Gamma_\varepsilon$ and that $n \leq \|z\|_\infty < n + 1$. Since $0 \leftrightarrow z$ in $\mathcal{G}_\varepsilon^*$, we conclude that $0 \leftrightarrow S_n$ in $\mathcal{G}_\varepsilon^*$.

Suppose now that $0 \leftrightarrow S_n$ in $\mathcal{G}_\varepsilon^*$. Then there exists $z \in \Gamma_\varepsilon$ such that $\|z\|_\infty \geq n$, $0 \leftrightarrow z$ in $\mathcal{G}_\varepsilon^*$. As a consequence, $\bar{0} \leftrightarrow \bar{z}$ in \mathcal{G} . Since $\xi(\Lambda_{n+\varepsilon} \setminus \overset{\circ}{\Lambda}_{n-\varepsilon}) = 0$, it must be $\bar{z} \in \bar{\Lambda}_{n+\varepsilon}^c$, thus implying that $\bar{0} \leftrightarrow S_n$ in \mathcal{G} . \square

Lemma 4.6.3. *It holds*

$$\mathbb{P}_\lambda(\bar{0} \leftrightarrow S_n \mid B_\varepsilon) = \mathbb{P}_\lambda(0 \leftrightarrow S_n \text{ in } \mathcal{G}_\varepsilon \mid A_\varepsilon \cap B_\varepsilon) + o(1). \quad (4.50)$$

Proof. Since $\mathbb{P}_\lambda(A_\varepsilon^c \mid B_\varepsilon) = O(\varepsilon^d)$ we can write

$$\mathbb{P}_\lambda(\bar{0} \leftrightarrow S_n \mid B_\varepsilon) = \mathbb{P}_\lambda(\bar{0} \leftrightarrow S_n \mid A_\varepsilon \cap B_\varepsilon) + O(\varepsilon^d). \quad (4.51)$$

4.6 Proof of (4.15) in Proposition 4.3.1

From now on we suppose the event $A_\varepsilon \cap B_\varepsilon$ to take place. We want to apply Lemma 4.6.2. By independence, $\mathbb{P}_\lambda(\{\xi(\Lambda_{n+\varepsilon} \setminus \overset{\circ}{\Lambda}_{n-\varepsilon}) \geq 1\} \cap B_\varepsilon) = O(\varepsilon^{d+1})$, while $\mathbb{P}_\lambda(A_\varepsilon \cap B_\varepsilon) \geq C\varepsilon^d$ by (4.49). As a consequence,

$$\mathbb{P}_\lambda(\xi(\Lambda_{n+\varepsilon} \setminus \overset{\circ}{\Lambda}_{n-\varepsilon}) = 0 \mid A_\varepsilon \cap B_\varepsilon) = 1 + o(1).$$

By the above observation and Lemma 4.6.2, in the r.h.s. of (4.51) we can replace the event $\{\bar{0} \leftrightarrow S_n \text{ in } \mathcal{G}\}$ with the event $\{0 \leftrightarrow S_n \text{ in } \mathcal{G}_\varepsilon^*\}$ with an error $o(1)$. In particular to get (4.50) it is enough to show that

$$\mathbb{P}_\lambda(0 \leftrightarrow S_n \text{ in } \mathcal{G}_\varepsilon \mid A_\varepsilon \cap B_\varepsilon) = \mathbb{P}_\lambda(0 \leftrightarrow S_n \text{ in } \mathcal{G}_\varepsilon^* \mid A_\varepsilon \cap B_\varepsilon) + o(1). \quad (4.52)$$

Since the events $A_\varepsilon, B_\varepsilon$ do not depend on σ , and since the random variables of σ -type are i.i.d. w.r.t. \mathbb{P}_λ conditioned to ξ , we conclude that $\mathcal{G}_\varepsilon^*$ and $\mathcal{G}_\varepsilon^\#$ have the same law under $\mathbb{P}_\lambda(\cdot \mid A_\varepsilon \cap B_\varepsilon)$. Hence, in order to prove (4.52) it is enough to show that

$$\mathbb{P}_\lambda(0 \leftrightarrow S_n \text{ in } \mathcal{G}_\varepsilon \mid A_\varepsilon \cap B_\varepsilon) = \mathbb{P}_\lambda(0 \leftrightarrow S_n \text{ in } \mathcal{G}_\varepsilon^\# \mid A_\varepsilon \cap B_\varepsilon) + o(1). \quad (4.53)$$

Trivially, (4.53) follows from Lemma 4.6.4 below. The result stated in Lemma 4.6.4 is stronger than what we need here (we do not need the term $\xi(\Lambda_{n+2})$ in the expectation), and it is suited for a further application in the next section. \square

Lemma 4.6.4. *It holds $\mathbb{E}_\lambda[\xi(\Lambda_{n+2})\mathbb{1}(\mathcal{G}_\varepsilon^\# \neq \mathcal{G}_\varepsilon) \mid A_\varepsilon \cap B_\varepsilon] = o(1)$.*

Proof. Recall definition (4.36). Since the graphs \mathcal{G}_ε and $\mathcal{G}_\varepsilon^\#$ have the same vertex set \mathcal{V}_ε , by an union bound we can estimate

$$\begin{aligned} & \mathbb{E}_\lambda[\xi(\Lambda_{n+2})\mathbb{1}(\mathcal{G}_\varepsilon^\# \neq \mathcal{G}_\varepsilon) \mid A_\varepsilon \cap B_\varepsilon] \\ & \leq \sum_{x \prec_{\text{lex}} y \text{ in } \Gamma_\varepsilon} \mathbb{E}_\lambda[\xi(\Lambda_{n+2})\mathbb{1}(\varphi_x^\varepsilon = 1, \varphi_y^\varepsilon = 1, \varphi_0^\varepsilon = 1, \Psi_{x,y}^{\bar{x},\bar{y}} \neq \Psi_{x,y}^{x,y}) \mid A_\varepsilon \cap B_\varepsilon]. \end{aligned} \quad (4.54)$$

Note that $\xi(\Lambda_{n+2}) \leq \xi(\Lambda_{n+2} \setminus (R_x^\varepsilon \cup R_y^\varepsilon \cup R_0^\varepsilon)) + 3 =: Z$ whenever $\varphi_x^\varepsilon = \varphi_y^\varepsilon = \varphi_0^\varepsilon = 1$. We also observe that, under $\mathbb{P}_\lambda(\cdot \mid A_\varepsilon \cap B_\varepsilon)$, the random variables $Z, \varphi_x^\varepsilon, \varphi_y^\varepsilon, \mathbb{1}(\Psi_{x,y}^{\bar{x},\bar{y}} \neq \Psi_{x,y}^{x,y})$ are independent. As a consequence, (4.54) implies that

$$\mathbb{E}_\lambda[\xi(\Lambda_{n+2})\mathbb{1}(\mathcal{G}_\varepsilon^\# \neq \mathcal{G}_\varepsilon) \mid A_\varepsilon \cap B_\varepsilon] \leq c \sum_{x \in \Gamma_\varepsilon} \sum_{y \in \Gamma_\varepsilon \setminus \{0,x\}} p_\lambda(\varepsilon)^{2-\delta_{0,x}} P(\Psi_{x,y}^{\bar{x},\bar{y}} \neq \Psi_{x,y}^{x,y}), \quad (4.55)$$

where $\delta_{0,x}$ denotes the Kronecker delta.

Above we have used the definition of $p_\lambda(\varepsilon)$ given in (4.14), the fact that

$$\mathbb{P}_\lambda(\varphi_z^\varepsilon = 1 \mid A_\varepsilon \cap B_\varepsilon) = \begin{cases} 1 & \text{if } z = 0, \\ p_\lambda(\varepsilon) & \text{if } z \in \Gamma_\varepsilon \setminus \{0\}, \end{cases} \quad (4.56)$$

and the estimate (recall that $\mathbb{P}_\lambda(A_\varepsilon^c \mid B_\varepsilon) = o(1)$)

$$\mathbb{E}_\lambda[Z \mid A_\varepsilon \cap B_\varepsilon] \leq \frac{\mathbb{E}_\lambda[Z\mathbb{1}(B_\varepsilon)]}{\mathbb{P}_\lambda(A_\varepsilon \cap B_\varepsilon)} = \mathbb{E}_\lambda[Z] \frac{\mathbb{P}_\lambda(B_\varepsilon)}{\mathbb{P}_\lambda(A_\varepsilon \cap B_\varepsilon)} = \frac{\mathbb{E}_\lambda[Z]}{\mathbb{P}_\lambda(A_\varepsilon \mid B_\varepsilon)} = O(1).$$

From now on we distinguish between the RC model and the MA model.

• We consider the RC model. Recall that the connection function g is good. To simplify the notation we restrict to $m = 2$ and $r_2 = 1$ in Definition 4.1.3 (the general case is similar). For $i = 1, 2$, we set

$$\omega_i(\delta) := \sup\{|g(a) - g(b)| : a, b \in (r_{i-1}, r_i) \text{ and } |a - b| \leq \delta\}.$$

Since g is uniformly continuous in (r_{i-1}, r_i) we know that $\omega_i(\delta) \rightarrow 0$ when $\delta \rightarrow 0$, for $i = 1, 2$. Since g has support inside $(0, 1)$, $P(\Psi_{x,y}^{\bar{x},\bar{y}} \neq \Psi_{x,y}^{x,y}) = 0$ if $|x - y| \geq 1$ and $|\bar{x} - \bar{y}| \geq 1$. By taking ε small, this always happens if $|x - y| \geq 2$. Hence, in the sum inside (4.54) we can restrict to x, y with $|x - y| < 2$.

As a consequence we have

$$\text{r.h.s. of (4.55)} \leq c \sum_{x \in \Gamma_\varepsilon} \sum_{\substack{y \in \Gamma_\varepsilon \setminus \{0, x\}: \\ |x-y| < 2}} p_\lambda(\varepsilon)^{2-\delta_{0,x}} |g(|x - y|) - g(|\bar{x} - \bar{y}|)|. \quad (4.57)$$

It remains to prove that the r.h.s. of (4.57) is $o(1)$.

Since $|z - \bar{z}| < \sqrt{d}\varepsilon$ for all $z \in \Gamma_\varepsilon$, $|x - y|$ differs from $|\bar{x} - \bar{y}|$ by at most $2\sqrt{d}\varepsilon$. We set $M_{x,y} := \max\{|x - y|, |\bar{x} - \bar{y}|\}$ and $m_{x,y} := \min\{|x - y|, |\bar{x} - \bar{y}|\}$. Note that $m_{x,y} > 0$. Since g has support inside $(0, 1)$, in (4.57) we can restrict to the case $m_{x,y} < r_2 = 1$. Moreover, if we consider the following cases:

- (i) $0 = r_0 < m_{x,y} < M_{x,y} < r_1$,
- (ii) $r_1 < m_{x,y} < M_{x,y} < r_2 = 1$,

we can bound

$$|g(|x - y|) - g(|\bar{x} - \bar{y}|)| \leq \omega_1(2\sqrt{d}\varepsilon) \text{ in the case (i),}$$

$$|g(|x - y|) - g(|\bar{x} - \bar{y}|)| \leq \omega_2(2\sqrt{d}\varepsilon) \text{ in the case (ii).}$$

As a consequence the contribution in the r.h.s. of (4.57) of the pairs x, y with $x \neq 0$ and $M_{x,y}, m_{x,y}$ which satisfy case (i) or (ii), is bounded by $c\varepsilon^{-2d} p_\lambda(\varepsilon)^2 (\omega_1(2\sqrt{d}\varepsilon) + \omega_2(2\sqrt{d}\varepsilon)) = O(\omega_1(2\sqrt{d}\varepsilon) + \omega_2(2\sqrt{d}\varepsilon)) = o(1)$. Similarly the contribution in the r.h.s. of (4.57) of the pairs $x = 0, y$ with $M_{x,y}, m_{x,y}$ which satisfy case (i) or (ii), is $O(\omega_1(2\sqrt{d}\varepsilon) + \omega_2(2\sqrt{d}\varepsilon)) = o(1)$.

The other pairs x, y in (4.57) we have not considered yet satisfy (a) $m_{x,y} \leq r_1 \leq M_{x,y}$ or (b) $m_{x,y} \leq r_2 \leq M_{x,y}$. Defining $r := r_1$ in case (a) and $r := r_2$ in case (b), we can restrict to study the contribution in the r.h.s. of (4.57) of the pairs x, y which satisfy $m_{x,y} \leq r \leq M_{x,y}$. We now estimate such contribution. Since $m_{x,y} \geq |x - y| - 2\sqrt{d}\varepsilon$ and $M_{x,y} \leq |x - y| + 2\sqrt{d}\varepsilon$, it must be

$$r - 2\sqrt{d}\varepsilon \leq |x - y| \leq r + 2\sqrt{d}\varepsilon. \quad (4.58)$$

The number of points $y \in \Gamma_\varepsilon$ satisfying (4.58) are of order $O(\varepsilon^{-d+1})$, hence the pairs x, y with $m_{x,y} \leq r \leq M_{x,y}$ and $x \neq 0$ are of order $O(\varepsilon^{-2d+1})$ while the pairs x, y with $m_{x,y} \leq r \leq M_{x,y}$ and $x = 0$ are $O(\varepsilon^{-d+1})$. Bounding in both cases $|g(|x - y|) -$

4.7 Proof of (4.16) in Proposition 4.3.1

$g(|\bar{x} - \bar{y}|)$ by 1, we conclude that the contribution in the r.h.s. of (4.57) of the pairs x, y with $m_{x,y} \leq r \leq M_{x,y}$ is bounded by $O(\varepsilon^{-2d+1})p_\lambda(\varepsilon)^2 + O(\varepsilon^{-d+1})p_\lambda(\varepsilon) = o(1)$.

• We consider the MA model. As for (4.57) we have

$$\text{r.h.s. (4.55)} \leq \sum_{x \in \Gamma_\varepsilon} \sum_{\substack{y \in \Gamma_\varepsilon \setminus \{0\}, \\ |x-y| < 2}} p_\lambda(\varepsilon)^{2-\delta_{0,x}} |h(|x-y|) - h(|\bar{x}-\bar{y}|)|. \quad (4.59)$$

Since by assumption h is good, one can proceed exactly as done for the RC model and conclude that the r.h.s. of (4.59) is of order $o(1)$. \square

4.6.1 Conclusion of the proof of (4.15) in Proposition 4.3.1

By combining Lemmas 4.6.1 and 4.6.3 we get that $\tilde{\theta}_n(\lambda) = \mathbb{P}_\lambda(0 \leftrightarrow S_n \text{ in } \mathcal{G}_\varepsilon \mid A_\varepsilon \cap B_\varepsilon) + o(1)$. On the other hand, by construction the random graph \mathcal{G}_ε sampled according to $\mathbb{P}_\lambda(\cdot \mid A_\varepsilon \cap B_\varepsilon)$ has the same law of the random graph G_ε sampled according to $\mathbb{P}_\lambda^{(\varepsilon)}(\cdot \mid \eta_0^\varepsilon = 1)$. This implies that

$$\mathbb{P}_\lambda(0 \leftrightarrow S_n \text{ in } \mathcal{G}_\varepsilon \mid A_\varepsilon \cap B_\varepsilon) = \mathbb{P}_\lambda^{(\varepsilon)}(0 \leftrightarrow S_n \mid \eta_0^\varepsilon = 1) = \tilde{\theta}_n^{(\varepsilon)}(\lambda).$$

This completes the proof of (4.15) for $n = k$. As stated at the beginning, the choice $n = k$ was to simplify the notation, the proof is the same for general k .

4.7 Proof of (4.16) in Proposition 4.3.1

We use the same convention on constants c, c_1, c_2, \dots , on $O(\varepsilon^\alpha)$ and $o(1)$ as stated at the beginning of the previous section. Below we restrict to $n \geq 1$.

Due to (4.12) we need to prove that

$$\mathbb{E}_{0,\lambda} [|\text{Piv}_+(0 \leftrightarrow S_n)|] = \lim_{\varepsilon \downarrow 0} \mathbb{E}_\lambda^{(\varepsilon)} [|\text{Piv}(0 \leftrightarrow S_n)|] \quad (4.60)$$

(recall the definition of $\text{Piv}_+(0 \leftrightarrow S_n)$ given after (4.11)). We define the function $g : \mathbb{R}^d \times \mathcal{N} \rightarrow \mathbb{R}$ as

$$g(x, \xi) = \mathbf{1}(x \in R_0^\varepsilon) \int_\Sigma P(d\sigma) |\text{Piv}_+(0 \leftrightarrow S_n)(\xi, \sigma)|.$$

Then, by the property of the Palm distribution and of P (cf. [2, Thm. 12.2.II and Eq. (12.2.4)] and Section 4.3.1),

$$\begin{aligned} \lambda \varepsilon^d \mathbb{E}_{0,\lambda} [|\text{Piv}_+(0 \leftrightarrow S_n)|] &= \lambda E_{0,\lambda} \left[\int_{\mathbb{R}^d} dx g(x, \xi) \right] = \mathbb{E}_\lambda \left[\int_{\mathbb{R}^d} \xi(dx) g(x, \tau_x \xi) \right] = \\ &= \mathbb{E}_\lambda \left[\int_{R_0^\varepsilon} \xi(dx) |\text{Piv}_+(x \leftrightarrow S_n(x))| \right]. \end{aligned} \quad (4.61)$$

We recall that $S_n(x) = S_n + x$. We can write the last member of (4.61) as $\mathcal{C}_1 + \mathcal{C}_2$, with \mathcal{C}_1 and \mathcal{C}_2 defined below. We set $N_\varepsilon := \xi(R_0^\varepsilon)$. Then, using independence and

that N_ε is a Poisson r.v. with parameter $\lambda\varepsilon^d$, we get

$$\begin{aligned}
 \mathcal{C}_1 &:= \mathbb{E}_\lambda \left[\int_{R_0^\varepsilon} \xi(dx) |\text{Piv}_+(x \leftrightarrow S_n(x))| \mathbf{1}(N_\varepsilon \geq 2) \right] \\
 &\leq \mathbb{E}_\lambda [\xi(\Lambda_{n+2}) N_\varepsilon \mathbf{1}(N_\varepsilon \geq 2)] = \mathbb{E}_\lambda [(N_\varepsilon + \xi(\Lambda_{n+2} \setminus R_0^\varepsilon)) N_\varepsilon \mathbf{1}(N_\varepsilon \geq 2)] \quad (4.62) \\
 &\leq \mathbb{E}_\lambda [N_\varepsilon^2 \mathbf{1}(N_\varepsilon \geq 2)] + c_1 \mathbb{E}_\lambda [N_\varepsilon \mathbf{1}(N_\varepsilon \geq 2)] \leq c_2 \mathbb{E}_\lambda [N_\varepsilon^2 \mathbf{1}(N_\varepsilon \geq 2)] \\
 &= c_2 (\mathbb{E}_\lambda [N_\varepsilon^2] - \mathbb{P}_\lambda [N_\varepsilon = 1]) = c_2 (\lambda\varepsilon^d + \lambda^2\varepsilon^{2d} - \lambda\varepsilon^d e^{-\lambda\varepsilon^d}) = O(\varepsilon^{2d}).
 \end{aligned}$$

Remark 4.7.1. For the first inequality in (4.62) we point out that, given $x \in R_0^\varepsilon \cap \xi$, the set $\text{Piv}_+(x \leftrightarrow S_n(x))$ (referred to \mathcal{G}) must be contained in $\xi \cap \Lambda_{n+2}$. Indeed, if we take a path in \mathcal{G} from x to the complement of $x + (-n, n)^d$ and call y the first vertex of the path outside $x + (-n, n)^d$, then the euclidean distance between y and $x + (-n, n)^d$ is smaller than 1 (recall that all edges in \mathcal{G} have length smaller than 1). In particular, we have that $\|y\|_\infty < \|x\|_\infty + n + 1 \leq n + 2$. As a consequence, to know if $x \leftrightarrow S_n(x)$ in \mathcal{G} (or in the graph obtained by removing from \mathcal{G} a vertex z and the edges containing z), it is enough to know the vertexes of \mathcal{G} inside Λ_{n+2} and the edges formed by these vertexes.

We now bound the remaining contribution \mathcal{C}_2 :

$$\begin{aligned}
 \mathcal{C}_2 &:= \mathbb{E}_\lambda \left[\int_{R_0^\varepsilon} \xi(dx) |\text{Piv}_+(x \leftrightarrow S_n(x))| \mathbf{1}(N_\varepsilon = 1) \right] \\
 &= \mathbb{E}_\lambda [|\text{Piv}_+(\bar{0} \leftrightarrow S_n(\bar{0}))| \mathbf{1}(N_\varepsilon = 1)] = \mathbb{E}_\lambda [|\text{Piv}_+(\bar{0} \leftrightarrow S_n(\bar{0}))| \mathbf{1}(N_\varepsilon = 1) \mathbf{1}(A_\varepsilon)] \\
 &\quad + \mathbb{E}_\lambda [|\text{Piv}_+(\bar{0} \leftrightarrow S_n(\bar{0}))| \mathbf{1}(N_\varepsilon = 1) \mathbf{1}(A_\varepsilon^c)]. \quad (4.63)
 \end{aligned}$$

We note that (see also the computation of $\mathbb{E}_\lambda [N_\varepsilon^2 \mathbf{1}(N_\varepsilon \geq 2)]$ in (4.62))

$$\begin{aligned}
 \mathbb{E}_\lambda [|\text{Piv}_+(\bar{0} \leftrightarrow S_n(\bar{0}))| \mathbf{1}(N_\varepsilon = 1) \mathbf{1}(A_\varepsilon^c)] &\leq \mathbb{E}_\lambda [\xi(\Lambda_{n+2}) \mathbf{1}(N_\varepsilon = 1) \mathbf{1}(A_\varepsilon^c)] \\
 &\leq \sum_{y \in \Gamma_\varepsilon \setminus \{0\}} \mathbb{E}_\lambda [\xi(\Lambda_{n+2}) \mathbf{1}(N_\varepsilon = 1) \mathbf{1}(\xi(R_y^\varepsilon) \geq 2)] \\
 &\leq \sum_{y \in \Gamma_\varepsilon \setminus \{0\}} \mathbb{E}_\lambda [\xi(\Lambda_{n+2} \setminus (R_y^\varepsilon \cup R_0^\varepsilon))] \mathbb{P}_\lambda(N_\varepsilon = 1) \mathbb{P}_\lambda(\xi(R_y^\varepsilon) \geq 2) \\
 &\quad + 2 \sum_{y \in \Gamma_\varepsilon \setminus \{0\}} \mathbb{E}_\lambda [\xi(R_y^\varepsilon) \mathbf{1}(\xi(R_y^\varepsilon) \geq 2)] \mathbb{P}_\lambda(N_\varepsilon = 1) \leq \sum_{y \in \Gamma_\varepsilon \setminus \{0\}} O(\varepsilon^{3d}) = O(\varepsilon^{2d}). \quad (4.64)
 \end{aligned}$$

Since (4.61) = $\mathcal{C}_1 + \mathcal{C}_2$, by (4.62), (4.63) and (4.64), we get (note that $B_\varepsilon = \{N_\varepsilon = 1\}$)

$$\mathbb{E}_{0,\lambda} [|\text{Piv}_+(0 \leftrightarrow S_n)|] = \mathbb{E}_\lambda [|\text{Piv}_+(\bar{0} \leftrightarrow S_n(\bar{0}))| \mathbf{1}(A_\varepsilon \cap B_\varepsilon)] \cdot \frac{1}{\lambda\varepsilon^d} + o(1). \quad (4.65)$$

In what follows, given one of our random graphs on the grid Γ_ε as G_ε (cf. Section 4.3.2), \mathcal{G}_ε , $\mathcal{G}_\varepsilon^*$ and $\mathcal{G}_\varepsilon^\#$ (cf. Section 4.6), and given an event A regarding the graph, we call $\text{Piv}_+(A)$ the set of vertexes x of the graph for which the following property holds: the event A is realized by the graph under consideration, but it does not take place when removing from the graph the vertex x and all edges containing the vertex x .

4.7 Proof of (4.16) in Proposition 4.3.1

Lemma 4.7.2. *It holds*

$$\begin{aligned} \mathbb{E}_\lambda[|\text{Piv}_+(\bar{0} \leftrightarrow S_n(\bar{0}))|\mathbb{1}(A_\varepsilon \cap B_\varepsilon)] &= \\ &= \mathbb{E}_\lambda[|\text{Piv}_+(0 \leftrightarrow S_n \text{ in } \mathcal{G}_\varepsilon^*)|\mathbb{1}(A_\varepsilon \cap B_\varepsilon)] + o(\varepsilon^d). \end{aligned} \quad (4.66)$$

Proof. We can bound

$$\begin{aligned} & \mathbb{E}_\lambda[|\text{Piv}_+(\bar{0} \leftrightarrow S_n(\bar{0}))|\mathbb{1}(A_\varepsilon \cap B_\varepsilon)\mathbb{1}(\xi(\Lambda_{n+\varepsilon} \setminus \overset{\circ}{\Lambda}_{n-\varepsilon}) \geq 1)] \\ & \leq \mathbb{E}_\lambda[\xi(\Lambda_{n+2})\mathbb{1}(A_\varepsilon \cap B_\varepsilon)\mathbb{1}(\xi(\Lambda_{n+\varepsilon} \setminus \overset{\circ}{\Lambda}_{n-\varepsilon}) \geq 1)] \\ & \leq \mathbb{E}_\lambda[W\mathbb{1}(B_\varepsilon)\mathbb{1}(\xi(\Lambda_{n+\varepsilon} \setminus \overset{\circ}{\Lambda}_{n-\varepsilon}) \geq 1)] + \mathbb{E}_\lambda[\xi(\Lambda_{n+\varepsilon} \setminus \overset{\circ}{\Lambda}_{n-\varepsilon})\mathbb{1}(B_\varepsilon)] \quad (4.67) \\ & \leq c\mathbb{P}_\lambda(B_\varepsilon)\mathbb{P}_\lambda(\xi(\Lambda_{n+\varepsilon} \setminus \overset{\circ}{\Lambda}_{n-\varepsilon}) \geq 1) + \mathbb{E}_\lambda[\xi(\Lambda_{n+\varepsilon} \setminus \overset{\circ}{\Lambda}_{n-\varepsilon})]\mathbb{P}_\lambda(B_\varepsilon) \\ & = O(\varepsilon^{d+1}) = o(\varepsilon^d), \end{aligned}$$

where $W := \xi(\Lambda_{n+2} \setminus \Lambda_{n+\varepsilon}) + \xi(\overset{\circ}{\Lambda}_{n-\varepsilon} \setminus R_0^\varepsilon) + 1$ (note that the third inequality follows from the independence property of the Poisson point process). As a consequence, (4.66) follows by observing that

$$\begin{aligned} \mathbb{E}_\lambda[|\text{Piv}_+(\bar{0} \leftrightarrow S_n(\bar{0}))|\mathbb{1}(A_\varepsilon \cap B_\varepsilon)\mathbb{1}(\xi(\Lambda_{n+\varepsilon} \setminus \overset{\circ}{\Lambda}_{n-\varepsilon}) = 0)] &= \\ &= \mathbb{E}_\lambda[|\text{Piv}_+(0 \leftrightarrow S_n \text{ in } \mathcal{G}_\varepsilon^*)|\mathbb{1}(A_\varepsilon \cap B_\varepsilon)\mathbb{1}(\xi(\Lambda_{n+\varepsilon} \setminus \overset{\circ}{\Lambda}_{n-\varepsilon}) = 0)]. \end{aligned} \quad (4.68)$$

Let us justify the above observation. We assume that event $A_\varepsilon \cap B_\varepsilon$ is fulfilled and that $\xi(\Lambda_{n+\varepsilon} \setminus \overset{\circ}{\Lambda}_{n-\varepsilon}) = 0$. Recall that $\mathcal{G}_\varepsilon^*$ is obtained by restricting the graph \mathcal{G} to Λ_{n+1} and by sliding any vertex \bar{x} to x . Since $S_n(\bar{0}) \subset \Lambda_{n+\varepsilon} \setminus \overset{\circ}{\Lambda}_{n-\varepsilon}$, if $\bar{0} \leftrightarrow S_n(\bar{0})$ in \mathcal{G} then $\bar{0} \leftrightarrow y$ for some point $y \in \Lambda_{n-\varepsilon+1} \setminus \Lambda_{n+\varepsilon}$ (using that edges have length smaller than 1). It must be $y = \bar{v}$ for some $v \in \Gamma_\varepsilon$. Since $\|y - v\|_\infty \leq \varepsilon$, we conclude that $v \in \Lambda_{n+1} \setminus \Lambda_n$. Since we can restrict to paths from 0 to y with intermediate points lying inside $\Lambda_{n-\varepsilon}$, we have that all the intermediate points are of the form \bar{z} for some $z \in \Gamma_\varepsilon$. We therefore get that the above path realizing the event $\bar{0} \leftrightarrow S_n(\bar{0})$ in \mathcal{G} corresponds to a path in $\mathcal{G}_\varepsilon^*$ from 0 to v , $\|v\|_\infty \geq n$. On the other hand, since $\xi(\Lambda_{n+\varepsilon} \setminus \overset{\circ}{\Lambda}_{n-\varepsilon}) = 0$, any path in $\mathcal{G}_\varepsilon^*$ from 0 to v , with $\|v\|_\infty \geq n$, is obtained by sliding some path in \mathcal{G} from $\bar{0}$ to $\Lambda_{n+\varepsilon}^c$. As $S_n(\bar{0}) \subset \Lambda_{n+\varepsilon} \setminus \overset{\circ}{\Lambda}_{n-\varepsilon}$, these paths in \mathcal{G} must realize the event $\bar{0} \leftrightarrow S_n(\bar{0})$. This correspondence between paths implies a correspondence between (+)-pivotal points, leading to identity (4.68). \square

In the last term in (4.66) we can replace $\mathcal{G}_\varepsilon^*$ with $\mathcal{G}_\varepsilon^\#$, since they have the same law under \mathbb{P}_λ conditioned to ξ . Now we would like to replace $\mathcal{G}_\varepsilon^\#$ with \mathcal{G}_ε . This is possible due to Lemma 4.6.4. Indeed, we have

$$\mathbb{P}_\lambda(A_\varepsilon \cap B_\varepsilon) = \mathbb{P}_\lambda(B_\varepsilon)[1 - \mathbb{P}_\lambda(A_\varepsilon^c | B_\varepsilon)] = \mathbb{P}_\lambda(B_\varepsilon)(1 + o(1)) = \lambda\varepsilon^d(1 + o(1)), \quad (4.69)$$

thus implying that Lemma 4.6.4 is equivalent to the property

$$\mathbb{E}_\lambda[\xi(\Lambda_{n+2})\mathbb{1}(A_\varepsilon \cap B_\varepsilon)\mathbb{1}(\mathcal{G}_\varepsilon \neq \mathcal{G}_\varepsilon^\#)] = o(\varepsilon^d). \quad (4.70)$$

By combining (4.65), (4.66), (4.69) and (4.70) we conclude that

$$\mathbb{E}_{0,\lambda}[\text{Piv}_+(0 \leftrightarrow S_n)] = \mathbb{E}_\lambda[\text{Piv}_+(0 \leftrightarrow S_n \text{ in } \mathcal{G}_\varepsilon) \mid A_\varepsilon \cap B_\varepsilon] + o(1). \quad (4.71)$$

Due to the definition of the graph G_ε built on $(\Omega_\varepsilon, \mathbb{P}_\lambda^{(\varepsilon)})$ we have

$$\mathbb{E}_\lambda[\text{Piv}_+(0 \leftrightarrow S_n \text{ in } \mathcal{G}_\varepsilon) \mid A_\varepsilon \cap B_\varepsilon] = \mathbb{E}_\lambda^{(\varepsilon)}[\text{Piv}_+(0 \leftrightarrow S_n) \mid \eta_0^\varepsilon = 1]. \quad (4.72)$$

Above, and in what follows, events appearing in $\mathbb{E}_\lambda^{(\varepsilon)}, \mathbb{P}_\lambda^{(\varepsilon)}$ are referred to the graph G_ε .

By combining (4.71) and (4.72) we have achieved that

$$\mathbb{E}_{0,\lambda}[\text{Piv}_+(0 \leftrightarrow S_n)] = \lim_{\varepsilon \downarrow 0} \mathbb{E}_\lambda^{(\varepsilon)}[\text{Piv}_+(0 \leftrightarrow S_n) \mid \eta_0^\varepsilon = 1]. \quad (4.73)$$

To derive (4.60) from (4.73) it is enough to apply the following result:

Lemma 4.7.3. *It holds $\mathbb{E}_\lambda^{(\varepsilon)}[\text{Piv}_+(0 \leftrightarrow S_n) \mid \eta_0^\varepsilon = 1] = \mathbb{E}_\lambda^{(\varepsilon)}[\text{Piv}(0 \leftrightarrow S_n)]$.*

Proof. Using the fact that $\{\text{Piv}_+(0 \leftrightarrow S_n)\}$ is empty if $\eta_0^\varepsilon \neq 1$, we get

$$\begin{aligned} \mathbb{E}_\lambda^{(\varepsilon)}[\text{Piv}_+(0 \leftrightarrow S_n) \mid \eta_0^\varepsilon = 1] &= \frac{1}{p_\lambda(\varepsilon)} \sum_{x \in \Gamma_\varepsilon} \mathbb{E}_\lambda^{(\varepsilon)}[\mathbf{1}(x \in \text{Piv}_+(0 \leftrightarrow S_n)) \eta_0^\varepsilon] \\ &= \frac{1}{p_\lambda(\varepsilon)} \sum_{x \in \Gamma_\varepsilon} \mathbb{E}_\lambda^{(\varepsilon)}[\mathbf{1}(x \in \text{Piv}_+(0 \leftrightarrow S_n))] \\ &= \frac{1}{p_\lambda(\varepsilon)} \sum_{x \in \Gamma_\varepsilon} \mathbb{E}_\lambda^{(\varepsilon)}[\mathbf{1}(x \in \text{Piv}(0 \leftrightarrow S_n)) \eta_x^\varepsilon]. \end{aligned} \quad (4.74)$$

Since the events $\{x \in \text{Piv}(0 \leftrightarrow S_n)\}$ and $\{\eta_x^\varepsilon = 1\}$ are independent, the last expression equals $\sum_{x \in \Gamma_\varepsilon} \mathbb{E}_\lambda^{(\varepsilon)}[\mathbf{1}(x \in \text{Piv}(0 \leftrightarrow S_n))]$, thus concluding the proof. \square

Bibliography

- [1] V. Ambegoakar, B.I. Halperin, J.S. Langer. *Hopping Conductivity in Disordered Systems*. Phys, Rev B, **4**, pp. 2612–2620 (1971).
- [2] D.J. Daley, D. Vere–Jones. *An Introduction to the Theory of Point Processes*. New York, Springer Verlag (1988).
- [3] H. Duminil-Copin, A. Raoufi, V. Tassion. *Sharp phase transition for the random–cluster and Potts models via decision trees*. Ann. of Math., **189** (1), pp. 75–99 (2019).
- [4] H. Duminil-Copin, A. Raoufi, V. Tassion. *Exponential decay of connection probabilities for subcritical Voronoi percolation in \mathbb{R}^d* . To appear on Prob. Theory Rel. Fields., **173**, Issue 1-2, pp. 479–490 (2019).
- [5] A. Faggionato. *Mott’s law for the effective conductance of the Miller–Abrahams random resistor network*. In preparation. A preliminary version is available online as arXiv:1712.07980 (2018).

Bibliography

- [6] A. Faggionato, P. Mathieu. *Mott law as upper bound for a random walk in a random environment*. Comm. Math. Phys. **281**, pp. 263–286 (2008).
- [7] A. Faggionato, H. Schulz–Baldes, D. Spehner. *Mott law as lower bound for a random walk in a random environment*. Comm. Math. Phys., **263**, pp. 21–64 (2006).
- [8] J. Jiang, S. Zhang, T. Guo. *Russo’s Formula, Uniqueness of the Infinite Cluster, and Continuous Differentiability of Free Energy for Continuum Percolation*. J. Appl. Prob., **48 (3)**, pp. 597–610 (2011).
- [9] R. Meester, R. Roy. *Continuum percolation*. Cambridge Tracts in Mathematics **119**. First edition, Cambridge University Press, Cambridge (1996).
- [10] A. Miller, E. Abrahams. *Impurity Conduction at Low Concentrations*. Phys. Rev., **120**, pp. 745–755 (1960).
- [11] R. O’Donnell, M. Saks, O. Schramm, R. Servedio. *Every decision tree has an influential variable*. FOCS’05, pp. 31–39 (2005).
- [12] M. Pollak, M. Ortuño, A. Frydman. *The Electron Glass*, Cambridge University Press, United Kingdom, first edition (2013).
- [13] S. Shklovskii, A.L. Efros. *Electronic Properties of Doped Semiconductors*. Springer Verlag, Berlin, first edition (1984).
- [14] S. Ziesche. *Sharpness of the phase transition and lower bounds for the critical intensity in continuum percolation on \mathbb{R}^d* . Ann. Inst. H. Poincaré Probab. Statist., **54**, pp. 866–878 (2018).

Chapter 5

Left-right crossings in the Miller-Abrahams random resistor network on a Poisson point process

Alessandra Faggionato and Hlalo Alfie Mimun

Preliminary version with additional pictures

We consider the Miller-Abrahams (MA) random resistor network built on a homogeneous Poisson point process (PPP) on \mathbb{R}^d , $d \geq 2$. Points of the PPP are marked by i.i.d. random variables and the MA random resistor network is obtained by plugging an electrical filament between any pair of distinct points in the PPP. The conductivity of the filament between two points decays exponentially in their distance and depends on their marks in a suitable form prescribed by electron transport in amorphous materials. The graph obtained by keeping filaments with conductivity lower bounded by a threshold ϑ exhibits a phase transition at some ϑ_{crit} . Under the assumption that the marks are nonnegative (or nonpositive) and bounded, we show that in the supercritical phase the maximal number of vertex-disjoint left-right crossings in a box of size n is lower bounded by Cn^{d-1} apart an event of exponentially small probability. This result is one of the main ingredients entering in the proof of Mott's law in [5].

5.1 Introduction

The Miller-Abrahams (MA) random resistor network has been introduced in [13] to study the anomalous conductivity at low temperature in amorphous materials as doped semiconductors, in the regime of Anderson localization and at low density of impurities. It has been further investigated in the physical literature (cf. [1], [14] and references therein), where percolation properties have been heuristically analyzed. A fundamental target has been to get a more robust derivation of the so called Mott's law, which is a physical law predicting that at low temperature the conductivity of the above amorphous materials decays in a stretched exponential form as

$$\exp\{-\kappa\beta^{\frac{\alpha+1}{\alpha+d+1}}\} \tag{5.1}$$

for some constant $\kappa > 0$. Above β is the inverse temperature, $d \geq 2$ is the dimension of the medium and $\alpha \geq 0$ is a constant entering in the distribution of the ground state energies of the electron wavefunctions.

The MA random resistor network is defined from a translation invariant and ergodic simple point process $\{x_i\}$, marked by i.i.d. random variables $\{E_{x_i}\}$ with common law ν . It is obtained as follows. Given a realization $\{(x_i, E_{x_i})\}$ of the above marked simple point process, we associate to any unordered pair of distinct points $x_i \neq x_j$ a filament with electrical conductivity

$$c(x_i, x_j) := \exp \left\{ -\frac{2}{\gamma} |x_i - x_j| - \frac{\beta}{2} (|E_{x_i}| + |E_{x_j}| + |E_{x_i} - E_{x_j}|) \right\}, \quad (5.2)$$

where γ is the so-called localization length. The physically relevant distributions ν (for inorganic materials) are of the form $\nu_{\text{phys}}(dE) \propto \mathbf{1}(|E| \leq a_0) |E|^\alpha dE$ with $\alpha \geq 0$ and $a_0 > 0$.

We call $\sigma_n(\beta)$ the effective conductivity of the MA random resistor network restricted to the box centered at the origin with radius n . For simplicity we restrict to marked point processes $\{(x_i, E_i)\}$ with isotropic law. Then, as proved in [4] under suitable assumptions, as n goes to ∞ a.s. the rescaled effective conductivity $(2n)^{2-d} \sigma_n(\beta)$ converges to a non random finite limit $\sigma_\infty(\beta)$. In addition, $\sigma_\infty(\beta)$ equals the diffusion coefficient $d(\beta)$ of the so-called Mott's random walk introduced in [8]. The latter is the continuous-time random walk on $\{x_i\}$ with probability rate for a jump from x_i to $x_j \neq x_i$ given by $c(x_i, x_j)$. As a consequence, Mott's law can be stated both for the limiting conductivity $\sigma_\infty(\beta)$ in the MA random resistor network and for the diffusion coefficient $d(\beta)$ in Mott's random walk. We recall that, for Mott's random walk, upper and lower bounds of $d(\beta)$ in agreement with Mott's law have been proved in [6] and [8], respectively.

We suppose here that $\{x_i\}$ is a homogeneous Poisson point process (PPP) with density λ . Given $\vartheta \in (0, 1)$ we denote by $\text{MA}(\vartheta)$ the subgraph obtained from the MA resistor network by keeping only filaments of conductivity lower bounded by ϑ . It is known (cf. [2, 5, 7]) that there exists $\vartheta_{\text{crit}} \in (0, 1)$ such that $\text{MA}(\vartheta)$ a.s. percolates for $\vartheta < \vartheta_{\text{crit}}$ and a.s. does not percolate for $\vartheta > \vartheta_{\text{crit}}$. As discussed in [5], an important tool to rigorously prove Mott's law and characterize the constant κ in (5.1) consists in showing for $\vartheta < \vartheta_{\text{crit}}$ that, apart an event of exponentially small probability, there are in $\text{MA}(\vartheta)$ at least Cn^{d-1} disjoint left-right (LR) crossings, i.e. linear chains along the first direction. This is indeed our main result (cf. Theorem 3 in Section 5.2) under the assumption that the mark distribution ν has finite support included in $[0, +\infty)$ and including the origin. We point out that a positive lower bound of $\sigma_\infty(\beta)$ can be obtained by standard methods (cf. [11]) when having the above LR crossings property for $\text{MA}(\vartheta)$ with ϑ small enough. In this case a stochastic domination argument would allow to recycle the LR crossings property for supercritical percolation on \mathbb{Z}^d [9]. On the other hand, to have a fine control on $\sigma_\infty(\beta)$ as necessary for Mott's law, one needs the LR crossings property for all $\vartheta < \vartheta_c$. We also remark that an analysis of the subcritical $\text{MA}(\vartheta)$ (i.e. with $\vartheta > \vartheta_c$) has been provided in [7].

We comment now some technical aspects in the derivation of our contribution. To prove Theorem 3 we first show that it is enough to derive a similar result (given by Theorem 4 in Section 5.3) for a suitable random graph \mathbb{G}_* with vertexes in $\varepsilon\mathbb{Z}^d$,

5.1 Introduction

defined in terms of i.i.d. random variables parametrized by points in $\varepsilon\mathbb{Z}^d$ (cf. Section 5.3). The proof of Theorem 4 is then inspired by the renormalization procedure developed by Grimmett and Marstrand in [10] for site percolation on \mathbb{Z}^d and by a construction presented in [15, Section 4]. We recall that in [10] it is proved that the critical probability of a slab in \mathbb{Z}^d converges to the critical probability of \mathbb{Z}^d when the thickness of the slab goes to $+\infty$. Moreover, in [15] Tanemura studies the left–right crossings in the supercritical Boolean model with deterministic radius.

We point out that the renormalization method developed in [10] does not apply verbatim to our setting. In particular the adaptation of Lemma 6 in [10] to our setting presents several obstacles due to the spatial correlations in the MA resistor network. A main novelty here is to build, by a Grimmett-Marstrand-like renormalization procedure, an increasing family of quasi-clusters in our graph \mathbb{G}_* . We use the term “quasi-cluster” since usually these sets are not connected in \mathbb{G}_* and can present some cuts at suitable localized regions. By expressing the PPP of density λ as superposition of two independent PPP’s with density $\lambda - \delta$ and $\delta \ll 1$, respectively, a quasi-cluster is built only by means of points in the PPP with density $\lambda - \delta$. On the other hand, we will show that, with high probability, when superposing the PPP with density δ we will insert a family of points x with very small mark E_x , which will link with the quasi-cluster, making the resulting set connected in \mathbb{G}_* . The quasi-clusters are produced by iterative steps, in which we attempt to enlarge the set. A lower bound of the probability that this attempt is successful, conditioned to the previous steps, is provided in Lemma 5.6.1, while measurability and the geometric properties of the quasi-clusters are analyzed in Section 5.7.

We finally comment our assumptions. We point out that the Grimmett-Marstrand method relies on the FKG inequality. Also for the MA resistor network one can introduce a natural ordering of the random objects, but it turns out that the FKG inequality is valid only when the marks are a.s. nonnegative (or nonpositive). In fact, in this case, the term $|E_{x_i}| + |E_{x_j}| + |E_{x_i} - E_{x_j}|$ in (5.2) equals $2 \max\{E_{x_i}, E_{x_j}\}$, and therefore it increases when increasing E_{x_i} or E_{x_j} . The restriction to marks with a given sign is therefore motivated by the use of the FKG inequality. On the other hand, our results cover mark distributions ν of the form $\nu(dE) \propto \mathbf{1}(0 \leq E \leq a_0)E^\alpha dE$ for $\alpha \geq 0$ and $a_0 > 0$, which share several scaling properties with the physical distributions ν_{phys} . We stress that these scaling properties are relevant in the heuristic derivation of Mott’s law as well in its rigorous analysis [5]. Our other assumption concerns the choice of the point process $\{x_i\}$, which is a PPP. From a technical viewpoint, this choice avoids to introduce further spatial dependence in the model. On the other hand, the PPP plays a special role for Mott’s law. Due to (5.2) one expects that, when $\beta \gg 1$, points x with $|E_x|$ not small give a negligible contribution to the conductivity. Hence one expects that, asymptotically as $\beta \rightarrow +\infty$, the conductivity is the same as for the Miller-Abrahams resistor network obtained from the set $\{x_i : |E_{x_i}| \leq E(\beta)\}$ for a suitable function $E(\beta)$ with $\lim_{\beta \rightarrow +\infty} E(\beta) = 0$. If in general $\{x_i\}$ is sampled according to a stationary ergodic point process with finite density ρ , it then follows that the thinned set $\{x_i : |E_{x_i}| \leq E(\beta)\}$ converges to a PPP with density ρ when rescaling points as $x \mapsto \nu([-E(\beta), E(\beta)])^{1/d}x$. Hence the PPP should be the emerging point process when $\beta \rightarrow +\infty$. This argument was indeed used in [8] to motivate the universality of Mott’s law.

5.2 Model and main results

Given $\lambda > 0$ and a probability measure ν on \mathbb{R} , we consider the marked Poisson point process (PPP) obtained by taking a homogeneous PPP ξ of density λ on \mathbb{R}^d and marking each point $x \in \xi$ independently with a random variable E_x having distribution ν (i.e., conditionally to ξ , the marks $(E_x)_{x \in \xi}$ are i.i.d. random variables with distribution ν). The above marked point process is usually called the ν -randomization of the PPP with density λ . We call Ω the configuration space of the above marked point process and write $\omega = \{(x, E_x) : x \in \xi\}$ for a generic element in Ω .

Definition 5.2.1. *Given $\zeta > 0$ we associate to $\omega = \{(x, E_x) : x \in \xi\}$ the graph $\mathcal{G} = \mathcal{G}(\lambda, \nu, \zeta)$ with vertex set ξ and edge set given by the pairs $\{x, y\} \subset \xi$ with $x \neq y$ and such that*

$$|x - y| + |E_x| + |E_y| + |E_x - E_y| \leq \zeta. \quad (5.3)$$

For later use, we point out that, given $E, E' \in \mathbb{R}$, it holds

$$|E| + |E'| + |E - E'| = \begin{cases} 2 \max(|E|, |E'|) & \text{if } E \cdot E' \geq 0, \\ 2|E - E'| & \text{if } E \cdot E' \leq 0. \end{cases} \quad (5.4)$$

The above graph \mathcal{G} corresponds to the resistor network obtained from the Miller-Abrahams resistor network by keeping only filaments with conductivity lower bounded by $e^{-\zeta}$ (without loss of generality we have set $\gamma := 2$ and $\beta := 2$, γ being the localization length and β being the inverse temperature).

Given a generic graph with vertexes in \mathbb{R}^d , one says that it percolates if it has an unbounded connected component. We recall (see [2, 5]) that there exists a critical length $\zeta_c(\lambda, \nu)$ such that

$$\mathbb{P}(\mathcal{G}(\lambda, \nu, \zeta) \text{ percolates}) = \begin{cases} 1 & \text{if } \zeta > \zeta_c(\lambda, \nu), \\ 0 & \text{if } \zeta < \zeta_c(\lambda, \nu). \end{cases} \quad (5.5)$$

Definition 5.2.2. *Given $L > 0$, a left-right (LR) crossing of the box $[-L, L]^d$ in the graph $\mathcal{G} = \mathcal{G}(\lambda, \nu, \zeta)$ is any sequence of distinct points $x_1, x_2, \dots, x_n \in \xi$ such that*

- $\{x_i, x_{i+1}\} \in \mathcal{E}$ for all $i = 1, 2, \dots, n - 1$;
- $x_1 \in (-\infty, -L) \times [-L, L]^{d-1}$;
- $x_2, x_3, \dots, x_{n-1} \in [-L, L]^d$;
- $x_n \in (L, +\infty) \times [-L, L]^{d-1}$.

We also define $R_L(\mathcal{G})$ as the maximal number of vertex-disjoint LR crossings of $[-L, L]^d$ in \mathcal{G} .

Our main result is the following one:

Theorem 3. *Suppose that ν has bounded support contained in $[0, +\infty)$ or in $(-\infty, 0]$ and suppose that 0 belongs to the support of ν . Then, given $\lambda > 0$ and $\zeta > \zeta_c(\lambda, \nu)$, there exist positive constants c, c' such that*

$$\mathbb{P}\left(R_L(\mathcal{G}) \geq cL^{d-1}\right) \geq 1 - e^{-c'L^{d-1}}, \quad (5.6)$$

for L large enough, where $\mathcal{G} = \mathcal{G}(\lambda, \nu, \zeta)$.

5.3 Discretization

In this section we show how to reduce the problem of estimating the probability $\mathbb{P}\left(R_L(\mathcal{G}) \geq cL^{d-1}\right)$ to a similar problem for a graph with vertexes contained in a lattice.

Lemma 5.3.1. *To prove Theorem 3 it is enough to consider the case $\zeta = 1 > \zeta_c(\lambda, \nu)$.*

Proof. We fix $\zeta > \zeta_c(\lambda, \nu)$ and we let \mathcal{G} be as in Theorem 3. The linear map $x \mapsto \psi(x) := x/\zeta$ gives a graph isomorphism between \mathcal{G} and its image \mathcal{G}' . Note that \mathcal{G}' has the same law of $\mathcal{G}(\lambda', \nu, 1)$, where $\lambda' := \lambda\zeta^d$. Due to the above isomorphism, we also have that $\zeta_c(\lambda', \nu) = \zeta_c(\lambda, \nu)/\zeta$ and the condition $\zeta > \zeta_c(\lambda, \nu)$ reads $1 > \zeta_c(\lambda', \nu)$. To conclude it is enough to observe that $R_L(\mathcal{G}) \geq cL^{d-1}$ if and only if $R_{L'}(\mathcal{G}') \geq c\zeta^{d-1}(L')^{d-1}$ where $L' := L/\zeta$, hence it is enough to focus on $\mathcal{G}' = \mathcal{G}(\lambda', \nu, 1)$. \square

Warning 5.3.1. *Due to Lemma 5.3.1, without any loss of generality we take once and for all $\zeta = 1$ in Theorem 3 and assume that $\zeta = 1 > \zeta_c(\lambda, \nu)$. In particular, \mathcal{G} will always denote the graph $\mathcal{G}(\lambda, \nu, 1)$. Moreover, we fix once and for all a constant $C_0 > 0$ such that ν has support inside $[0, C_0]$. By symmetry, the case of nonpositive marks can be treated similarly.*

Lemma 5.3.2. *There exist $\lambda_* \in (0, \lambda)$ and $u_* \in (\zeta_c(\lambda, \nu), 1)$ such that*

$$\mathbb{P}(\mathcal{G}(\rho, \nu, u) \text{ percolates}) = 1 \quad \forall \rho \geq \lambda_*, \forall u \geq u_*. \quad (5.7)$$

Proof. Let $\zeta_c := \zeta_c(\lambda, \nu)$. It is trivial to build a coupling such that $\mathcal{G}(\rho, \nu, u) \subset \mathcal{G}(\rho', \nu, u')$ if $\rho \leq \rho'$ and $u \leq u'$. As a consequence, we only need to show that there exist $\lambda_* < \lambda$ and $u_* \in (\zeta_c, 1)$ such that $\mathbb{P}(\mathcal{G}(\rho_*, \nu, u_*) \text{ percolates}) = 1$. To this aim we fix $\zeta' \in (\zeta_c, 1)$. Fixed $\gamma \in (0, 1)$, $\mathcal{G}(\lambda, \nu, \zeta')$ can be described also as the graph with vertex set ξ given by a PPP with density λ and edge set \mathcal{E}' given by the pairs $\{x, y\} \subset \xi$ with $x \neq y$ and

$$\begin{aligned} |x/\gamma - y/\gamma| + |E_x| + |E_y| + |E_x - E_y| \\ \leq \zeta'/\gamma - (1/\gamma - 1)(|E_x| + |E_y| + |E_x - E_y|), \end{aligned} \quad (5.8)$$

where the marks come from the ν -randomization of the PPP ξ . Note that the r.h.s. of (5.8) is bounded from above by $\zeta'/\gamma - 3C_0(1/\gamma - 1)$, which goes to ζ' as $\gamma \uparrow 1$. In particular, we can fix γ very near to 1 (from the left) to have $u_* := \zeta'/\gamma - 3C_0(1/\gamma - 1) \in (\zeta_c, 1)$. We now introduce the graph $\hat{\mathcal{G}} = (\xi, \hat{\mathcal{E}})$ where $\{x, y\} \in \hat{\mathcal{E}}$ if $\{x, y\} \subset \xi$, $x \neq y$ and

$$|x/\gamma - y/\gamma| + |E_x| + |E_y| + |E_x - E_y| \leq u_*. \quad (5.9)$$

Since the r.h.s. of (5.8) is bounded by u_* by our choice of γ , $\hat{\mathcal{G}}$ contains $\mathcal{G}(\lambda, \nu, \zeta')$. Since $\mathbb{P}(\mathcal{G}(\lambda, \nu, \zeta') \text{ percolates}) = 1$ by (5.5), we get that $\mathbb{P}(\hat{\mathcal{G}} \text{ percolates}) = 1$. On the other hand, due to (5.9), the graph obtained by rescaling $\hat{\mathcal{G}}$ according to the map $x \mapsto x/\gamma$ has the same law of the graph $\mathcal{G}(\lambda\gamma^d, \nu, u_*)$. Since $\mathbb{P}(\hat{\mathcal{G}} \text{ percolates}) = 1$, we conclude that $\mathbb{P}(\mathcal{G}(\lambda\gamma^d, \nu, u_*) \text{ percolates}) = 1$. It is therefore enough to take $\lambda_* := \lambda\gamma^d$. \square

We need to introduce some notation since we will deal with several couplings:

- We write $\text{PPP}(\rho)$ for the Poisson point process with density ρ .
- We write $\text{PPP}(\rho, \nu)$ for the marked PPP obtained as ν -randomization of a $\text{PPP}(\rho)$.
- We write $\mathcal{L}(\rho, \nu)$ for the law of $\inf\{X_1, X_2, \dots, X_N\}$, where $(X_n)_{n \geq 1}$ is a sequence of i.i.d. random variables with law ν and N is a Poisson random variable with parameter ρ . When $N = 0$, the set $\{X_1, X_2, \dots, X_N\}$ is given by \emptyset .

Above, and in what follows, we use the convention $\inf \emptyset := +\infty$.

Definition 5.3.3 (Parameters α, ε). *We fix α small enough such that $1 - 10\alpha \geq u_*$ (see Lemma 5.3.2) and such that $\sqrt{d}/\alpha \in \mathbb{N}_+$. We define ε by $\varepsilon\sqrt{d} := \alpha/100$ (note that $1/\varepsilon \in \mathbb{N}_+$). For each $z \in \varepsilon\mathbb{Z}^d$ we set $R_z := z + [0, \varepsilon]^d$.*

We fix a positive integer K , very large. In Section 5.14 we will explain how to choose K .

Definition 5.3.4. *Let $\lambda_* \in (0, \lambda)$ be as in Lemma 5.3.2. We introduce the following independent random fields defined on a common probability space (Θ, \mathbb{P}) :*

- Let $(A_z)_{z \in \varepsilon\mathbb{Z}^d}$ be i.i.d. random variables with law $\mathcal{L}(\lambda_*\varepsilon^d, \nu)$.
- For $j = 1, 2, \dots, K$ let $(T_z^{(j)})_{z \in \varepsilon\mathbb{Z}^d}$ be i.i.d. random variables with law $\mathcal{L}((\lambda - \lambda_*)\varepsilon^d/K, \nu)$.

Definition 5.3.5. *On the probability space (Θ, \mathbb{P}) we define the graphs $\mathbb{G}_{\natural} = (\mathbb{V}, \mathbb{E}_{\natural})$, $\mathbb{G} = (\mathbb{V}, \mathbb{E})$ and $\mathbb{G}_* = (\mathbb{V}_*, \mathbb{E}_*)$ with vertices in $\varepsilon\mathbb{Z}^d$ as follows.*

The vertex set \mathbb{V} is given by $\mathbb{V} := \{z \in \varepsilon\mathbb{Z}^d : A_z < +\infty\}$. The edge set \mathbb{E} is given by the unordered pairs $\{z, z'\}$ with $z \neq z'$ in \mathbb{V} such that

$$|z - z'| + 2 \max\{A_z, A_{z'}\} \leq 1 - 2\alpha, \quad (5.10)$$

while the edge set \mathbb{E}_{\natural} is given by the unordered pairs $\{z, z'\}$ with $z \neq z'$ in \mathbb{V} such that

$$|z - z'| + 2 \max\{A_z, A_{z'}\} \leq 1 - 3\alpha. \quad (5.11)$$

The vertex set \mathbb{V}_ is given by*

$$\mathbb{V}_* := \{z \in \varepsilon\mathbb{Z}^d : A_z \wedge \min_{1 \leq j \leq K} T_z^{(j)} < +\infty\}. \quad (5.12)$$

The edge set \mathbb{E}_ is given by the unordered pairs $\{z, z'\}$ with $z \neq z'$ in \mathbb{V}_* and*

$$|z - z'| + 2 \max\{A_z \wedge \min_{1 \leq j \leq K} T_z^{(j)}, A_{z'} \wedge \min_{1 \leq j \leq K} T_{z'}^{(j)}\} \leq 1 - \alpha. \quad (5.13)$$

Trivially $\mathbb{G}_{\natural} \subset \mathbb{G} \subset \mathbb{G}_*$. Note also that the graphs \mathbb{G} and \mathbb{G}_{\natural} depend only on the random field $(A_z)_{z \in \varepsilon\mathbb{Z}^d}$. The graph \mathbb{G} will play an important role in the next sections.

5.3 Discretization

Definition 5.3.6. Given $L > 0$, a left-right (LR) crossing of the box $\Delta_L := [-L - 2, L + 2] \times [-L, L]^{d-1}$ in the graph \mathbb{G}_* is any sequence of distinct vertexes x_1, x_2, \dots, x_n of \mathbb{G}_* such that

- $\{x_i, x_{i+1}\} \in \mathbb{E}_*$ for all $i = 1, 2, \dots, n - 1$;
- $x_1 \in (-\infty, -L - 2) \times [-L, L]^{d-1}$;
- $x_2, x_3, \dots, x_{n-1} \in \Delta_L$;
- $x_n \in (L + 2, +\infty) \times [-L, L]^{d-1}$.

We also define $\mathbb{R}_L(\mathbb{G}_*)$ as the maximal number of vertex-disjoint LR crossings of Δ_L in \mathbb{G}_* .

Theorem 4. Let \mathbb{G}_* be the random graph given in Definition 5.3.5. Then there exist positive constants c, c' such that

$$\mathbb{P}\left(\mathbb{R}_L(\mathbb{G}_*) \geq cL^{d-1}\right) \geq 1 - e^{-c'L^{d-1}} \quad (5.14)$$

for L large enough.

The rest of the paper will be devoted to the proof of Theorem 4 due to the following fact:

Proposition 5.3.7. Theorem 4 implies Theorem 3.

An important tool to prove Theorem 4 will be the following:

Lemma 5.3.8. The graph $\mathbb{G}_\#$ percolates \mathbb{P} -a.s.

At this point, we can disregard the original problem and the original random objects. One could start afresh keeping in mind only Definitions 5.3.3, 5.3.4, 5.3.5 and 5.3.6 and Lemma 5.3.8. The next sections will be devoted to the proof of Theorem 4.

The proofs of Proposition 5.3.7 and Lemma 5.3.8 are postponed to Subsections 5.3.1 and 5.3.2 below, respectively. We end with some observations concerning the FKG inequality.

On the probability space (Θ, \mathbb{P}) we introduce the partial ordering \preceq as follows: given $\theta_1, \theta_2 \in \Theta$ we say that $\theta_1 \preceq \theta_2$ if, for all $z \in \varepsilon\mathbb{Z}^d$ and $j \in \{1, 2, \dots, K\}$, it holds

$$A_z(\theta_1) \geq A_z(\theta_2), \quad T_z^{(j)}(\theta_1) \geq T_z^{(j)}(\theta_2).$$

We point out that, if $\theta_1 \preceq \theta_2$, then $\mathbb{G}_\#(\theta_1) \subset \mathbb{G}_\#(\theta_2)$, $\mathbb{G}(\theta_1) \subset \mathbb{G}(\theta_2)$ and $\mathbb{G}_*(\theta_1) \subset \mathbb{G}_*(\theta_2)$. We stress that the above inclusions follow from Definition 5.3.5 and expressions (5.10), (5.11), (5.13) there come from our restriction to nonnegative marks in the original Miller–Abrahams random resistor network, thus ensuring that $|E| + |E'| + |E - E'| = 2 \max(E, E')$.

Since dealing with i.i.d. random variables, we have also that the partial ordering \preceq satisfies the FKG inequality: if F, G are increasing events for \preceq , then $\mathbb{P}(F \cap G) \geq \mathbb{P}(F)\mathbb{P}(G)$.

5.3.1 Proof of Proposition 5.3.7

We first clarify the relation of the random fields introduced in Definition 5.3.4 with the marked PPP(λ, ν). We observe that a PPP(λ, ν) can be obtained as follows. Let

$$\{(x, E_x) : x \in \sigma\}, \quad (5.15)$$

$$\{(x, E_x) : x \in \xi^{(j)}\} \quad j = 1, 2, \dots, K, \quad (5.16)$$

be independent marked PPP's, respectively with law PPP(λ_*, ν) and PPP($(\lambda - \lambda_*)/K, \nu$). The random sets σ and $\xi^{(j)}$, with $1 \leq j \leq K$, are disjoint a.s.. To simplify that notation, at cost to remove an event of probability zero, from now on we suppose that σ and $\xi^{(j)}$, with $1 \leq j \leq K$, are disjoint subsets of \mathbb{R}^d . Then, setting $\xi := \sigma \cup (\cup_{j=1}^K \xi^{(j)})$, we have that $\{(x, E_x) : x \in \xi\}$ is a PPP(λ, ν). We define

$$B_z := \inf\{E_x : x \in \sigma \cap R_z\}, \quad z \in \varepsilon\mathbb{Z}^d, \quad (5.17)$$

$$B_z^{(j)} := \inf\{E_x : x \in \xi^{(j)} \cap R_z\}, \quad z \in \varepsilon\mathbb{Z}^d, \quad j = 1, 2, \dots, K. \quad (5.18)$$

We note that $(B_z)_{z \in \varepsilon\mathbb{Z}^d}$ has the same law of $(A_z)_{z \in \varepsilon\mathbb{Z}^d}$ and $(B_z^{(j)})_{z \in \varepsilon\mathbb{Z}^d}$ has the same law of $(T_z^{(j)})_{z \in \varepsilon\mathbb{Z}^d}$, for $j = 1, 2, \dots, K$. Moreover the above fields in (5.17) and (5.18) are independent. Trivially, we have

$$B_z \wedge \min_{1 \leq j \leq K} B_z^{(j)} = \inf\{E_x : x \in \xi \cap R_z\}, \quad z \in \varepsilon\mathbb{Z}^d. \quad (5.19)$$

By the above discussion \mathbb{G}_* has the same law of the following graph $\bar{\mathbb{G}}$ built in terms of the marked point processes (5.15) and (5.16). The vertex set of $\bar{\mathbb{G}}$ is given by $\{z \in \varepsilon\mathbb{Z}^d : B_z \wedge \min_{1 \leq j \leq K} B_z^{(j)} < +\infty\}$. The edges of $\bar{\mathbb{G}}$ are given by the unordered pairs $\{z, z'\}$ with $z \neq z'$ in the vertex set and

$$|z - z'| + 2 \max\{B_z \wedge \min_{1 \leq j \leq K} B_z^{(j)}, B_{z'} \wedge \min_{1 \leq j \leq K} B_{z'}^{(j)}\} \leq 1 - \alpha. \quad (5.20)$$

Due to (5.19) for each vertex z of $\bar{\mathbb{G}}$ we can fix a point $x(z) \in \xi \cap R_z$ such that $E_{x(z)} = B_z \wedge \min_{1 \leq j \leq K} B_z^{(j)}$. Hence, if $\{z, z'\}$ is an edge of $\bar{\mathbb{G}}$, then $x(z)$ and $x(z')$ are defined and it holds $|z - z'| + 2 \max\{E_{x(z)}, E_{x(z')}\} \leq 1 - \alpha$. As $x(z) \in R_z$ it must be $|x(z) - z| \leq \sqrt{d}\varepsilon = \alpha/100$ and, similarly, $|x(z') - z'| \leq \alpha/100$. It then follows that $|x - y| + 2 \max\{E_x, E_y\} \leq 1$ where $x = x(z)$ and $y = x(z')$. This implies that $\{x, y\}$ is an edge of $\mathcal{G}(\lambda, \nu, 1)$ (recall Warning 5.3.1).

We extend Definition 5.3.6 to $\bar{\mathbb{G}}$ (it is enough to replace \mathbb{G}_* by $\bar{\mathbb{G}}$ there). Due to the above discussion, if z_1, z_2, \dots, z_n is a LR crossing of the box Δ_L for $\bar{\mathbb{G}}$, then we can extract from $x(z_1), x(z_2), \dots, x(z_n)$ a LR crossing of the box $[-L - 1, L + 1]^d$ for $\mathcal{G}(\lambda, \nu, 1)$ (we use that $\varepsilon < 1$). Since disjointness is preserved, we deduce that $R_{L+1}(\mathcal{G}(\lambda, \nu, 1)) \geq \mathbb{R}_L(\bar{\mathbb{G}})$. Due to this inequality Theorem 4 implies Theorem 3 (by changing the constants c, c' when moving from Theorem 4 to Theorem 3).

5.3.2 Proof of Lemma 5.3.8

Let $\{(x, E_x) : x \in \sigma\}$ be a PPP(λ_*, ν) as in (5.15) and let $(B_z)_{z \in \varepsilon\mathbb{Z}^d}$ be the random field introduced in (5.17). We recall that $(B_z)_{z \in \varepsilon\mathbb{Z}^d}$ has the same law of $(A_z)_{z \in \varepsilon\mathbb{Z}^d}$.

5.4 Basic geometrical objects in the discrete context

In particular, it is enough to prove that the graph $\bar{\mathbb{G}}_{\natural}$ percolates a.s., where $\bar{\mathbb{G}}_{\natural}$ is defined as \mathbb{G}_{\natural} with A_z replaced by B_z . Take $x \neq y$ in σ such that

$$|x - y| + 2 \max\{E_x, E_y\} \leq u_* . \quad (5.21)$$

Equivalently, $\{x, y\}$ is an edge of the graph $\mathcal{G}(\lambda_*, \nu, u_*)$ built by means of the marked PPP $\{(x, E_x) : x \in \sigma\}$. Let $z(x)$ and $z(y)$ be the points in $\varepsilon\mathbb{Z}^d$ such that $x \in R_{z(x)}$ and $y \in R_{z(y)}$. Trivially, $|z(x) - x| \leq \varepsilon\sqrt{d}$, $|z(y) - y| \leq \varepsilon\sqrt{d}$, $B_{z(x)} \leq E_x$ and $B_{z(y)} \leq E_y$. Then from (5.21) and Definition 5.3.3 we get

$$|z(x) - z(y)| + 2 \max\{B_{z(x)}, B_{z(y)}\} \leq u_* + 2\varepsilon\sqrt{d} \leq 1 - 3\alpha . \quad (5.22)$$

As a consequence, for each edge $\{x, y\}$ in $\mathcal{G}(\lambda_*, \nu, u_*)$, either we have $z(x) = z(y)$ or we have that $\{z(x), z(y)\}$ is an edge of $\bar{\mathbb{G}}_{\natural}$. Since $\mathcal{G}(\lambda_*, \nu, u_*)$ percolates a.s., due to the above observation we conclude that $\bar{\mathbb{G}}_{\natural}$ percolates a.s..

5.4 Basic geometrical objects in the discrete context

In the rest we will often write $\mathbb{P}(E_1, E_2, \dots, E_n)$ instead of $\mathbb{P}(E_1 \cap E_2 \cap \dots \cap E_n)$, also for other probabilities.

Recall the Definition 5.3.5 of the graphs $\mathbb{G}_{\natural} = (\mathbb{V}, \mathbb{E}_{\natural})$, $\mathbb{G} = (\mathbb{V}, \mathbb{E})$ and $\mathbb{G}_* = (\mathbb{V}_*, \mathbb{E}_*)$. We introduce the following conventions:

- Given $x \in \mathbb{V}$ and $C \subset \mathbb{V}$ with $x \notin C$, we say that x is directly connected to C inside \mathbb{G} if there exists $y \in C$ such that $\{x, y\} \in \mathbb{E}$.
- Given $A, B, C \subset \varepsilon\mathbb{Z}^d$, we say that “ $A \leftrightarrow B$ in C for \mathbb{G} ” if there exist $x_1, x_2, \dots, x_k \in C \cap \mathbb{V}$ such that $x_1 \in A$, $x_k \in B$ and $\{x_i, x_{i+1}\} \in \mathbb{E}$ for all $i : 1 \leq i < k$.
- Given a bounded set $A \subset \mathbb{R}^d$ we say that “ $A \leftrightarrow \infty$ for \mathbb{G} ” if there exists an unbounded path in \mathbb{G} starting at some point in A .

Similar definitions hold for the graphs $\mathbb{G}_{\natural} = (\mathbb{V}, \mathbb{E}_{\natural})$ and $\mathbb{G}_* = (\mathbb{V}_*, \mathbb{E}_*)$.

Definition 5.4.1. For $m \leq n \in \mathbb{N}_+$, $z \in \varepsilon\mathbb{Z}^d$, $\sigma \in \{-1, 1\}^d$, $J \in \{1, 2, \dots, d\}$ we define the following sets (see Figure 5.1-(left) and Figure 5.2)

$$\begin{aligned} B(m) &:= [-m, m]^d \cap \varepsilon\mathbb{Z}^d \text{ and } B(z, m) := z + B(m), \\ A(n) &:= \{x \in \varepsilon\mathbb{Z}^d : n - 1 < \|x\|_{\infty} \leq n\}, \\ T(n) &:= \{x \in \varepsilon\mathbb{Z}^d : n - 1 < \|x\|_{\infty} \leq n, 0 \leq x_i \leq x_1 \forall i = 1, 2, \dots, d\}, \\ T_{\sigma, J}(n) &:= \{x \in \varepsilon\mathbb{Z}^d : n - 1 < \|x\|_{\infty} \leq n, 0 \leq \sigma_i x_i \leq \sigma_J x_J \forall i = 1, 2, \dots, d\}, \\ T(m, n) &:= ([n + \varepsilon, n + \varepsilon + 2m] \times [0, n]^{d-1}) \cap \varepsilon\mathbb{Z}^d. \end{aligned}$$

Note that $T_{\underline{1}, 1}(n) = T(n)$, where $\underline{1} := (1, 1, \dots, 1)$. The following fact can be easily checked:

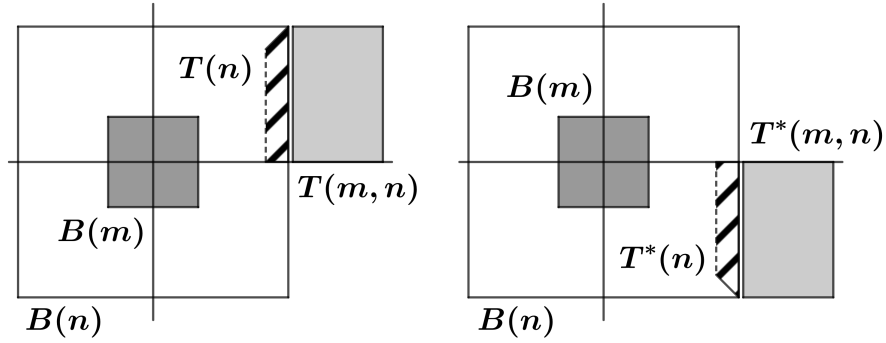

Figure 5.1. Left: sets $T(n)$ and $T(m, n)$. Right: sets $T^*(n)$ and $T^*(m, n)$.

Lemma 5.4.2. *We have the following properties:*

(i) $A(n) = \cup_{\sigma \in \{-1, 1\}^d} \cup_{J=1}^d T_{\sigma, J}(n)$;

(ii) given (σ, J) the map

$$\psi_{\sigma, J}(x_1, x_2, \dots, x_d) := (y_1, y_2, \dots, y_d),$$

where

$$y_k := \begin{cases} x_J \sigma_1 & \text{if } k = 1, \\ x_1 \sigma_J & \text{if } k = J, \\ x_k \sigma_k & \text{otherwise,} \end{cases} \quad (5.23)$$

is an isometry from $T(n)$ to $T_{\sigma, J}(n)$ and it is the identity when $\sigma = \underline{1}$ and $J = 1$.

Proof. To prove Item (i) we take $x \in \varepsilon \mathbb{Z}^d$ with $n-1 < \|x\|_\infty \leq n$. We take J as any coordinate such that $|x_J| = \|x\|_\infty = \max\{|x_1|, |x_2|, \dots, |x_d|\}$ and define $\sigma_i := +1$ if $x_i \geq 0$, otherwise we set $\sigma_i := -1$, for any $i = 1, \dots, d$. By this choice $\sigma_i x_i = |x_i|$, thus implying that $0 \leq |x_i| = \sigma_i x_i \leq \|x\|_\infty = \sigma_J x_J$. This completes the proof of Item (i).

We move to Item (ii). Since any permutation of coordinates is an isometry and since changing the sign of a coordinate is an isometry, the map $\psi_{\sigma, J}$ is an isometry of \mathbb{R}^d . Trivially, $\|x\|_\infty = \|y\|_\infty$. Note that $x_1 = \sigma_J y_J$ and $x_J = \sigma_1 y_1$, while $x_i = \sigma_i y_i$ for $i \neq 1, J$. Therefore the bound $0 \leq x_i \leq x_1$ reads $0 \leq \sigma_i y_i \leq \sigma_J y_J$ for $i \neq 1, J$, it reads $0 \leq \sigma_J y_J \leq \sigma_J y_J$ for $i = 1$ and reads $0 \leq \sigma_1 y_1 \leq \sigma_J y_J$ for $i = J$. This proves that $\psi_{\sigma, J}$ maps $T(n)$ into $T_{\sigma, J}(n)$. Being an isometry on all \mathbb{R}^d , $\psi_{\sigma, J}$ must be bijective from $T(n)$ to $T_{\sigma, J}(n)$. The fact that $\psi_{\underline{1}, 1}$ is the identity is trivial. \square

Definition 5.4.3. *Given $z \in \varepsilon \mathbb{Z}^d$ and $m \in \mathbb{N}_+$, we say that $B(z, m)$ is a seed if $B(z, m) \subset \mathbb{V}$ and $A_x \leq \alpha/100$ for all $x \in B(z, m)$.*

Definition 5.4.4. *Given $m \leq n \in \mathbb{N}_+$, $K(m, n)$ is given by the points $x \in T(n)$ which are directly connected inside \mathbb{G} to a seed contained in $T(m, n)$. Equivalently, $K(m, n)$ is given by the points $x \in \mathbb{V} \cap T(n)$ such that, for some $z \in \varepsilon \mathbb{Z}^d$, the box $B(z, m) \subset T(m, n)$ is a seed and $\exists y \in B(z, m)$ with $\{x, y\} \in \mathbb{E}$.*

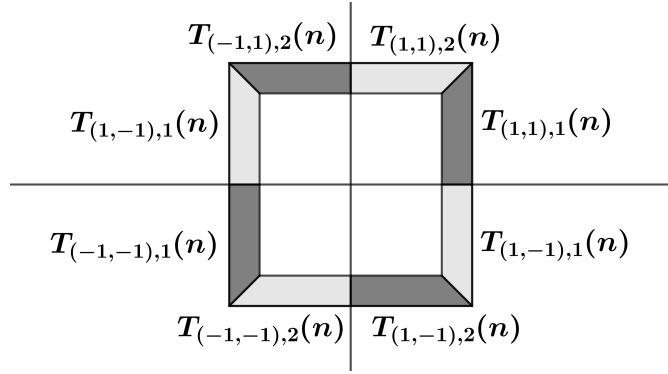

Figure 5.2. The sets $T_{\sigma,J}(n)$.

Lemma 5.4.5. *If $B(z, m)$ is a seed, then $B(z, m)$ is a connected subset in the graph \mathbb{G} .*

Proof. Recall that $B(z, m) \subset \mathbb{V}$ since $B(z, m)$ is a seed. Let x, y be points in $B(z, m)$ with $|x - y| = \varepsilon$. Since $\varepsilon = \alpha/100\sqrt{d}$, we get $|x - y| \leq \alpha/100$. By definition of seed, we have $|A_x|, |A_y| \leq \alpha/100$. Then trivially $|x - y| + 2 \max\{A_x, A_y\} \leq 3\alpha/100$. By Definition 5.3.3 it holds $1 - 10\alpha \geq u_* > 0$, hence $\alpha < 0.1$ and therefore $3\alpha/100 < 1 - 2\alpha$. This proves that $\{x, y\} \in \mathbb{E}$ for any x, y in $B(z, m)$ with $|x - y| = \varepsilon$. It is trivial to conclude. \square

Proposition 5.4.6. *Given $\eta \in (0, 1)$, there exist positive integers $m = m(\eta)$ and $n = n(\eta)$ such that $m > 2$, $2m < n$, $2m|n$ and*

$$\mathbb{P}(B(m) \leftrightarrow K(m, n) \text{ in } B(n) \text{ for } \mathbb{G}) > 1 - \eta. \quad (5.24)$$

5.5 Proof of Proposition 5.4.6

Recall Definition 5.4.1. The following lemma and its proof are inspired by [10, Lemma 3] and its proof.

Lemma 5.5.1. *Let m and n be positive integers such that $n > m$. Let U_n be the set of points $x \in A(n)$ such that $B(m) \leftrightarrow x$ in $B(n)$ for \mathbb{G}_\natural and*

$$d(x, B(n)^c) + 2A_x \leq 1 - 3\alpha, \quad (5.25)$$

where $d(\cdot, \cdot)$ denotes the Euclidean distance. Then, for each integer k , it holds

$$\sum_{n=m+1}^{\infty} \mathbb{P}(|U_n| < k, B(m) \leftrightarrow \infty \text{ for } \mathbb{G}_\natural) < e^{c(d)\lambda_* k}. \quad (5.26)$$

for a positive constant $c(d)$ depending only on the dimension.

Proof. We claim that the event $\{B(m) \leftrightarrow \infty \text{ for } \mathbb{G}_\natural\}$ implies that $|U_n| \geq 1$. To prove our claim we observe that, since the edges in \mathbb{G}_\natural have length at most $1 - 3\alpha$, the event

$\{B(m) \leftrightarrow \infty \text{ for } \mathbb{G}_\natural\}$ implies that there exists $x \in A(n)$ such that $B(m) \leftrightarrow x$ in $B(n)$ for \mathbb{G}_\natural and $\{x, y\} \in \mathbb{E}_\natural$ for some $y \in B(n)^c \cap \mathbb{V}$. Indeed, it is enough to take any path from $B(m)$ to ∞ for \mathbb{G}_\natural and define y as the first visited point in $B(n)^c$ and x as the point visited before y . Note that the property $\{x, y\} \in \mathbb{E}_\natural$ implies (5.25) by (5.11). Hence $x \in U_n$. This concludes the proof of our claim. Due to the above claim we have

$$\mathbb{P}(|U_n| < k, B(m) \leftrightarrow \infty \text{ for } \mathbb{G}_\natural) \leq \mathbb{P}(1 \leq |U_n| < k). \quad (5.27)$$

We now want to estimate $\mathbb{P}(U_{n+1} = \emptyset \mid 1 \leq |U_n| < k)$ from below (the result will be given in (5.29) below).

For each $x \in U_n$ we denote by $I_{n+1}(x)$ the set of points y in $A(n+1)$ such that $|x - y| \leq 1 - 3\alpha$. We call G_n the event that \mathbb{V} has no points in $\cup_{x \in U_n} I_{n+1}(x)$. We now claim that $G_n \subset \{U_{n+1} = \emptyset\}$. To prove our claim let z be in U_{n+1} . Then there is a path in \mathbb{G}_\natural from z to some point in $B(m)$ visiting only points in $B(n+1)$. We call v the last point in the path inside $A(n+1)$ and x the next point in the path. Then $x \in A(n)$ and all the points visited by the path after x are in $B(n)$. Hence, $B(m) \leftrightarrow x$ in $B(n)$ for \mathbb{G}_\natural . Moreover, since $\{x, v\} \in \mathbb{E}_\natural$, property (5.25) is verified. Then $x \in U_n$ and \mathbb{V} has some point (indeed v) in $I_{n+1}(x)$. In particular, we have shown that, if $U_{n+1} \neq \emptyset$, then G_n does not occur, thus proving our claim.

Recall that the graph \mathbb{G}_\natural depends only on the random field $(A_z)_{z \in \varepsilon\mathbb{Z}^d}$ and that $\mathbb{P}(A_z = +\infty) = e^{-\lambda_* \varepsilon^d}$ for any $z \in \varepsilon\mathbb{Z}^d$. We call \mathcal{F}_n the σ -algebra generated by the random variables A_z with $z \in B(n)$. Note that the set $\cup_{x \in U_n} I_{n+1}(x)$ and the event $\{1 \leq |U_n| < k\}$ are \mathcal{F}_n -measurable. Moreover, on the event $\{1 \leq |U_n| < k\}$, the set $\cup_{x \in U_n} I_{n+1}(x)$ has cardinality bounded by $c(d)k\varepsilon^{-d}$, where $c(d)$ is a positive constant depending only on d . By the independence of the A_z 's we conclude that that \mathbb{P} -a.s. on the event $\{1 \leq |U_n| < k\}$ it holds

$$\begin{aligned} \mathbb{P}(G_n \mid \mathcal{F}_n) &= \mathbb{P}(A_z = +\infty \forall z \in \cup_{x \in U_n} I_{n+1}(x) \mid \mathcal{F}_n) \\ &\geq \mathbb{P}(A_0 = +\infty)^{c(d)k\varepsilon^{-d}} = e^{-c(d)\lambda_* k}. \end{aligned} \quad (5.28)$$

Hence, since $G_n \subset \{U_{n+1} = \emptyset\}$, by (5.28) we conclude that

$$\mathbb{P}(U_{n+1} = \emptyset \mid 1 \leq |U_n| < k) \geq \mathbb{P}(G_n \mid 1 \leq |U_n| < k) \geq \exp\{-c(d)\lambda_* k\}. \quad (5.29)$$

As a byproduct of (5.27) and (5.29) we get

$$\begin{aligned} e^{-c(d)\lambda_* k} \mathbb{P}(|U_n| < k, B(m) \leftrightarrow \infty \text{ for } \mathbb{G}_\natural) &\leq e^{-c(d)\lambda_* k} \mathbb{P}(1 \leq |U_n| < k) \\ &\leq \mathbb{P}(U_{n+1} = \emptyset \mid 1 \leq |U_n| < k) \mathbb{P}(1 \leq |U_n| < k) \\ &= \mathbb{P}(U_{n+1} = \emptyset, 1 \leq |U_n| < k). \end{aligned} \quad (5.30)$$

Since the events $\{U_{n+1} = \emptyset, 1 \leq |U_n| < k\}$ are disjoint, we get (5.26). \square

We now present the analogous of [10, Lemma 4].

Lemma 5.5.2. *Let $w := 2^d d$ and call V_n the set of points $x \in T(n)$ satisfying (5.25) and such that $B(m) \leftrightarrow x$ in $B(n)$ for \mathbb{G}_\natural . Then, for any $\ell \in \mathbb{N}$, it holds*

$$\liminf_{n \rightarrow \infty} \mathbb{P}(|V_n| \geq \ell) \geq 1 - \mathbb{P}(B(m) \not\leftrightarrow \infty \text{ for } \mathbb{G}_\natural)^{1/w}. \quad (5.31)$$

5.5 Proof of Proposition 5.4.6

Proof. Let σ, J be as in Definition 5.4.1. If in the definition of V_n we take $T_{\sigma, J}(n)$ instead of $T(n)$, then we call $V_{\sigma, J, n}$ the resulting set. Note that $V_{\underline{1}, 1, n} = V_n$. By Lemma 5.4.2–(i) we get that $|U_n| \leq \sum_{(\sigma, J)} |V_{\sigma, J, n}|$, hence

$$\{|U_n| < w\ell\} \supset \cap_{(\sigma, J)} \{|V_{\sigma, J, n}| < \ell\}. \quad (5.32)$$

By the FKG inequality and since each event $\{|V_{\sigma, J, n}| < \ell\}$ is decreasing, and by the isometries given in Lemma 5.4.2–(ii), we have

$$\mathbb{P}(|U_n| < w\ell) \geq \prod_{(\sigma, J)} \mathbb{P}(|V_{\sigma, J, n}| < \ell) = \mathbb{P}(|V_n| < \ell)^w.$$

The above bound implies that $\mathbb{P}(|V_n| \geq \ell) \geq 1 - \mathbb{P}(|U_n| < w\ell)^{1/w}$. On the other hand we have

$$\begin{aligned} \mathbb{P}(|U_n| < w\ell) &\leq \mathbb{P}(|U_n| < w\ell, B(m) \leftrightarrow \infty \text{ for } \mathbb{G}_{\natural}) \\ &\quad + \mathbb{P}(B(m) \not\leftrightarrow \infty \text{ for } \mathbb{G}_{\natural}) \end{aligned} \quad (5.33)$$

and by Lemma 5.5.1 the first term in the r.h.s. goes to zero as $n \rightarrow \infty$, thus implying the thesis. \square

We can finally give the proof of Proposition 5.4.6.

Proof of Proposition 5.4.6. By Lemma 5.3.8 \mathbb{G}_{\natural} percolates \mathbb{P} -a.s., hence we can fix an integer $m > 2$ such that

$$\mathbb{P}(B(m) \not\leftrightarrow \infty \text{ for } \mathbb{G}_{\natural}) < (\eta/2)^w, \quad w := d2^d. \quad (5.34)$$

Then, by Lemma 5.5.2, for any $\ell \in \mathbb{N}$ we have

$$\liminf_{n \rightarrow \infty} \mathbb{P}(|V_n| \geq \ell) \geq 1 - \mathbb{P}(B(m) \not\leftrightarrow \infty \text{ for } \mathbb{G}_{\natural})^{1/w} > 1 - \eta/2. \quad (5.35)$$

We set $\rho := \mathbb{P}(B(m) \text{ is a seed}) \in (0, 1)$ and fix an integer M large enough that $(1 - \rho)^M < \eta/2$. We set $\ell := (2m)^{d-1} 3^{d-1} M \varepsilon^{-d}$ and, by (5.35), we can fix n large enough that $\mathbb{P}(|V_n| \geq \ell) > 1 - \eta/2$, $2m < n$ and $2m|n$.

Since $2m|n$ we can partition $[0, n]^{d-1}$ in non-overlapping $(d-1)$ -dimensional closed boxes D_i^* , $i \in \mathcal{I}$, of side length $2m$ (by “non-overlapping” we mean that the interior parts are disjoint). We set $D_i := D_i^* \cap \varepsilon \mathbb{Z}^d$. Note that $T(n) \subset \cup_{i \in \mathcal{I}} (n-1, n] \times D_i$ and $T(m, n) = \cup_{i \in \mathcal{I}} ([n+\varepsilon, n+\varepsilon+2m] \cap \varepsilon \mathbb{Z}) \times D_i$ (see Figure 5.3).

By construction, any set $(n-1, n] \times D_i$ contains at most $(2m)^{d-1} \varepsilon^{-d}$ points $x \in T(n)$. Since $\ell = (2m)^{d-1} 3^{d-1} M \varepsilon^{-d}$, the event $\{|V_n| \geq \ell\}$ implies that there exists $\mathcal{I}_* \subset \mathcal{I}$ with $|\mathcal{I}_*| = 3^{d-1} M$ fulfilling the following property: for any $k \in \mathcal{I}_*$ there exists $x \in V_n$ with $x \in (n-1, n] \times D_k$. We can choose univocally \mathcal{I}_* by defining it as the set of the first (w.r.t. the lexicographic order) M indexes $k \in \mathcal{I}$ satisfying the above property. We now thin \mathcal{I}_* since we want to deal with disjoint sets D_k 's. To this aim we observe that each D_k can intersect at most $3^{d-1} - 1$ other sets of the form $D_{k'}$. Hence, there must exist $\mathcal{I}_{\natural} \subset \mathcal{I}_*$ such that $D_k \cap D_{k'} = \emptyset$ for any $k \neq k'$ in \mathcal{I}_{\natural} and such that $|\mathcal{I}_{\natural}| = M$ (again \mathcal{I}_{\natural} can be fixed deterministically by using the lexicographic order). We introduce the events

$$G_k := \{([n+\varepsilon, n+\varepsilon+2m] \cap \varepsilon \mathbb{Z}) \times D_k \text{ is a seed}\}. \quad (5.36)$$

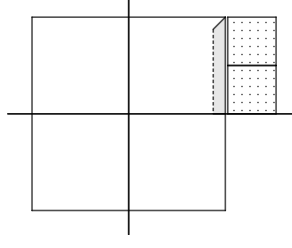

Figure 5.3. The dotted region corresponds to the boxes $([n + \varepsilon, n + \varepsilon + 2m] \cap \varepsilon\mathbb{Z}) \times D_i$ with $i \in \mathcal{I}_*$

We claim that

$$\mathbb{P}\left(\{|V_n| \geq \ell\} \cap (\cup_{k \in \mathcal{I}_\natural} G_k)\right) \geq 1 - \eta. \quad (5.37)$$

To this aim we call \mathcal{F}_n the σ -algebra generated by the r.v.'s A_z with $z \in B(n)$. We observe that the event $\{|V_n| \geq \ell\}$ belongs to \mathcal{F}_n , the set \mathcal{I}_\natural is \mathcal{F}_n -measurable and w.r.t. $\mathbb{P}(\cdot | \mathcal{F}_n)$ the events $\{G_k : k \in \mathcal{I}_\natural\}$ are independent (recall that $D_k \cap D_{k'} = \emptyset$ for any $k \neq k'$ in \mathcal{I}_\natural) and each G_k has probability $\rho := \mathbb{P}(B(m)$ is a seed). Hence, \mathbb{P} -a.s. on the event $\{|V_n| \geq \ell\}$ we can bound

$$\mathbb{P}(\cup_{k \in \mathcal{I}_\natural} G_k | \mathcal{F}_n) \geq 1 - (1 - \rho)^M > 1 - \eta/2. \quad (5.38)$$

Note that the last bound follows from our choice of M . Since, by our choice of n , $\mathbb{P}(|V_n| \geq \ell) > 1 - \eta/2$, we conclude that the l.h.s. of (5.37) is lower bounded by $(1 - \eta/2)^2 > 1 - \eta$. This concludes the proof of (5.37).

Let us now suppose that $|V_n| \geq \ell$ and that the event G_k takes place for some $k \in \mathcal{I}_\natural$. We claim that necessarily $B(m) \leftrightarrow K(m, n)$ in $B(n)$ for \mathbb{G} . Note that the above claim and (5.37) lead to (5.24). We prove our claim. As discussed before (5.36), since $k \in \mathcal{I}_\natural$ there exists $x \in V_n \cap ((n - 1, n] \times D_k)$. Let S be the seed $([n + \varepsilon, n + \varepsilon + 2m] \cap \varepsilon\mathbb{Z}) \times D_k$. By definition of V_n , $d(x, B(n)^c) + 2A_x \leq 1 - 3\alpha$ and $B(m) \leftrightarrow x$ in $B(n)$ for \mathbb{G}_\natural . Note that $x' \in \{n\} \times D_k$ as $V_n \subset T(n)$. Let $y := x' + \varepsilon e_1$. Then $y \in S$ and therefore $A_y \leq \alpha/100$ (since S is a seed) and $|x' - y| = \varepsilon \leq \alpha/100$. Then we have

$$\begin{aligned} |x - y| + 2 \max\{A_x, A_y\} &\leq |x - x'| + |x' - y| + 2A_x + 2A_y \\ &\leq d(x, B(n)^c) + \alpha/100 + 2A_x + \alpha/50 \leq 1 - 3\alpha + 3\alpha/100 < 1 - 2\alpha. \end{aligned} \quad (5.39)$$

We have therefore shown that $B(m) \leftrightarrow x$ in $B(n)$ for \mathbb{G}_\natural for some $x \in T(n)$ with $\{x, y\} \in \mathbb{E}$ for some $y \in S$. As a consequence, $x \in K(m, n)$. Since $\mathbb{G}_\natural \subset \mathbb{G}$, we get that $B(m) \leftrightarrow K(m, n)$ in $B(n)$ for \mathbb{G} . \square

5.6 The fundamental lemma

Given a finite set $R \subset \varepsilon\mathbb{Z}^d$, we define the non-random boundary set

$$\partial R := \{y \in \varepsilon\mathbb{Z}^d \setminus R : d(y, R) \leq 1 - 2\alpha\}, \quad (5.40)$$

5.6 The fundamental lemma

where $d(\cdot, \cdot)$ denotes the Euclidean distance. To avoid ambiguity, we point out that in what follows the set $\partial R \cap B(n)$ has to be thought of as $(\partial R) \cap B(n)$ and not as $\partial(R \cap B(n))$.

Recall Definition 5.3.4. Since the support of ν contains zero, the constant $\gamma := \mathbb{P}(T_0^{(j)} \leq \alpha/100)$ is strictly positive.

Lemma 5.6.1. *Fix $\varepsilon' \in (0, 1)$. Then there exist positive integers m and n , with $m > 2$, $2m < n$ and $2m|n$, satisfying the following property.*

Consider the following sets (see Figure 5.4):

- *Let R be a finite subset of $\varepsilon\mathbb{Z}^d$ satisfying*

$$B(m) \subset R, \quad (R \cup \partial R) \cap (T(n) \cup T(m, n)) = \emptyset. \quad (5.41)$$

- *For any $x \in R \cup \partial R$, let $\Lambda(x)$ be a subset of $\{1, 2, \dots, K\}$. We suppose that there exists $k_* \in \{1, 2, \dots, K\}$ such that*

$$k_* \notin \cup_{x \in D} \Lambda(x), \quad (5.42)$$

where $D \subset \varepsilon\mathbb{Z}^d$ is defined as

$$D := (\partial R \cap B(n)) \cup \{x \in R : \exists y \in \partial R \cap B(n) \text{ with } |x - y| \leq 1 - 2\alpha\}. \quad (5.43)$$

Consider the following events:

- *Let H be any measurable event w.r.t. the σ -algebra \mathcal{F} generated by the random variables $(A_x)_{x \in R \cup \partial R}$ and $(T_x^{(j)})_{x \in R \cup \partial R, j \in \Lambda(x)}$.*
- *Let G be the event that there exists a string $(z_0, z_1, z_2, \dots, z_\ell)$ in \mathbb{V} such that*

- (P1) $z_0 \in R$;
- (P2) $z_1 \in \partial R \cap B(n)$;
- (P3) $z_2, \dots, z_\ell \in B(n) \setminus (R \cup \partial R)$;
- (P4) z_2, \dots, z_ℓ is a path in \mathbb{G} ;
- (P5) $z_\ell \in K(m, n)$;
- (P6) $T_{z_0}^{(k_*)} \leq \alpha/100$ and $T_{z_1}^{(k_*)} \leq \alpha/100$;
- (P7) $|z_0 - z_1| \leq 1 - 2\alpha$;
- (P8) $|z_1 - z_2| + 2A_{z_2} \leq 1 - 2\alpha$.

Then $\mathbb{P}(G | H) \geq 1 - \varepsilon'$.

We point out that the above properties (P6), (P7), (P8) (which can appear a little exotic now) will be crucial to derive the \mathbb{G}_* -connectivity issue stated in Lemma 5.7.2. Indeed, although $(z_0, z_1, z_2, \dots, z_\ell)$ could be not a path in \mathbb{G} , one can prove that it is a path in \mathbb{G}_* (in Lemma 5.7.2 we will state and prove the \mathbb{G}_* -connectivity property in the form relevant for our applications).

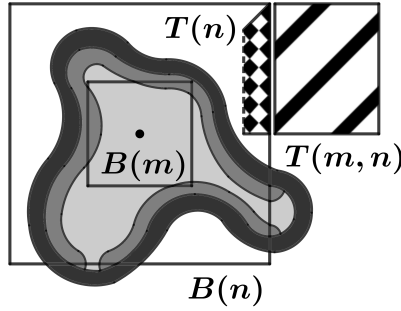

Figure 5.4. ∂R is the very dark grey contour. R is given by the light/dark grey region around the origin. D is the dark grey subset of \mathbb{R} .

5.6.1 Proof of Lemma 5.6.1

Recall that $\gamma := \mathbb{P}(T_0^{(j)} \leq \alpha/100) > 0$. We can fix a positive constant $c(d)$ such that the ball $\{y \in \mathbb{R}^d : |y| \leq 2\}$ contains at most $c(d)\varepsilon^{-d}$ points of $\varepsilon\mathbb{Z}^d$. We then choose t large enough that $(1 - \gamma^2)^{t\varepsilon^d/c(d)-1} \leq \varepsilon'/2$. Afterwards we choose $\eta > 0$ small enough so that $(1 - p)^{-t}\eta \leq \varepsilon'/2$, where

$$p := \mathbb{P}(A_x < +\infty) = 1 - \exp\{-\lambda_*\varepsilon^d\} < 1. \quad (5.44)$$

Then we take $m = m(\eta)$ and $n = n(\eta)$ as in Proposition 5.4.6. In particular, (5.24) holds and moreover

$$[1 - (1 - p)^{-t}\eta][1 - (1 - \gamma^2)^{t\varepsilon^d/c(d)-1}] \geq (1 - \varepsilon'/2)^2 > 1 - \varepsilon'. \quad (5.45)$$

Remark 5.6.2. As $\eta \leq \varepsilon'/2$, from (5.24) we get that

$$\mathbb{P}(B(m) \leftrightarrow K(m, n) \text{ in } B(n) \text{ for } \mathbb{G}) > 1 - \varepsilon'. \quad (5.46)$$

This will be used in other sections.

Lemma 5.6.3. In the same context of Lemma 5.6.1 let

$$\begin{aligned} V_R := \{x \in \partial R \cap B(n) : \exists y \in B(n) \setminus (R \cup \partial R) \text{ such that} \\ |x - y| + 2A_y \leq 1 - 2\alpha \text{ and} \\ \{y\} \leftrightarrow K(m, n) \text{ in } B(n) \setminus (R \cup \partial R) \text{ for } \mathbb{G}\}. \end{aligned}$$

Then we have (recall (5.44))

$$\mathbb{P}(|V_R| > t) \geq 1 - (1 - p)^{-t}\eta. \quad (5.47)$$

We postpone the proof of Lemma 5.6.3 to Subsection 5.6.2.

Remark 5.6.4. The random set V_R depends only on A_x with $x \in B(n) \setminus (R \cup \partial R)$ and A_x with $x \in T(m, n)$. Indeed, to determine $K(m, n)$, one needs to know the seeds inside $T(m, n)$.

5.6 The fundamental lemma

Given $x \in \partial R$ we define x_* as the minimal (w.r.t. lexicographic order) point $y \in R$ such that $|x - y| \leq 1 - 2\alpha$. Note that x_* exists for any $x \in V_R$ since $V_R \subset \partial R$. Let us show that $F \subset G$, where

$$F := \{\exists x \in V_R \text{ with } T_x^{(k_*)} \leq \alpha/100, T_{x_*}^{(k_*)} \leq \alpha/100\}.$$

To this aim, suppose the event F to be fulfilled and take $x \in V_R$ with $T_x^{(k_*)} \leq \alpha/100$ and $T_{x_*}^{(k_*)} \leq \alpha/100$. Since $x \in V_R$, by definition of V_R there exists $y \in B(n) \setminus (R \cup \partial R)$ such that $|x - y| + 2A_y \leq 1 - 2\alpha$ and there exists a path $(y, z_3, z_4, \dots, z_\ell)$ inside \mathbb{G} connecting y to $K(m, n)$ with vertexes in $B(n) \setminus (R \cup \partial R)$. We set $z_0 := x_*$, $z_1 = x$, $z_2 := y$. Then the event G is satisfied by the string $(z_0, z_1, \dots, z_\ell)$. This proves that $F \subset G$.

Since $F \subset G$ we can estimate

$$\begin{aligned} \mathbb{P}(G | H) &\geq \mathbb{P}(|V_R| > t, F | H) \\ &= \sum_{\substack{B \subset \partial R \cap B(n): \\ |B| > t}} \mathbb{P}(V_R = B, F_B | H), \end{aligned} \quad (5.48)$$

where

$$F_B := \{\exists x \in B \text{ with } T_x^{(k_*)} \leq \alpha/100, T_{x_*}^{(k_*)} \leq \alpha/100\}.$$

The event F_B is determined by the random variables $\{T_x^{(k_*)}\}_{x \in D}$. In particular (cf. Remark 5.6.4) the event $\{V_R = B\} \cap F_B$ is determined by

$$\begin{cases} T_x^{(k_*)} & \text{with } x \in D, \\ A_x & \text{with } x \in B(n) \setminus (R \cup \partial R) \text{ and with } x \in T(m, n). \end{cases}$$

Since by assumption H is \mathcal{F} -measurable, and due to conditions (5.41) and (5.42), we conclude that the event $\{V_R = B\} \cap F_B$ and H are independent. Hence $\mathbb{P}(V_R = B, F_B | H) = \mathbb{P}(V_R = B, F_B)$. In particular, coming back to (5.48), we have

$$\mathbb{P}(G | H) \geq \sum_{\substack{B \subset \partial R \cap B(n): \\ |B| > t}} \mathbb{P}(V_R = B, F_B). \quad (5.49)$$

To deal with $\mathbb{P}(V_R = B, F_B)$ we observe that the events $\{V_R = B\}$ and F_B are independent (see Remark 5.6.4), hence we get

$$\mathbb{P}(V_R = B, F_B) = \mathbb{P}(V_R = B)\mathbb{P}(F_B). \quad (5.50)$$

It remains to lower bound $\mathbb{P}(F_B)$. We first show that there exists a subset $\tilde{B} \subset B$ such that

$$|\tilde{B}| \geq |B|\varepsilon^d/c(d) - 1 \quad (5.51)$$

and such that all points of the form x or x_* , with $x \in \tilde{B}$, are distinct. We recall that the positive constant $c(d)$ has been introduced at the beginning of Subsection 5.6.1. To build the above set \tilde{B} we recall that $B \subset \partial R$ and that, for any $x \in B$, it holds $|x - x_*| \leq 1 - 2\alpha$ and $x_* \in R$. As a consequence, given $x, x' \in B$, x_* and x'_* are distinct if $|x - x'| \geq 2$ and moreover any point of the form x_* with $x \in B$ cannot

coincide with a point in B . Hence it is enough to exhibit a subset $\tilde{B} \subset B$ satisfying (5.51) and such that all points in \tilde{B} have reciprocal distance at least 2. We know that the ball \mathbb{B} of radius 2 contains at most $c(d)\varepsilon^{-d}$ points of $\varepsilon\mathbb{Z}^d$. The set \tilde{B} is then built as follows: choose a point a_1 in $B_1 := B$ and define $B_2 := B_1 \setminus (a_1 + \mathbb{B})$, then choose a point $a_2 \in B_2$ and define $B_3 := B_2 \setminus (a_2 + \mathbb{B})$ and so on until possible (each a_k can be chosen as the minimal point w.r.t. the lexicographic order). We call $\tilde{B} := \{a_1, a_2, \dots, a_s\}$ the set of chosen points. Since $|B_k| \geq |B| - (k-1)c(d)\varepsilon^{-d}$, we get that $s = |\tilde{B}|$ is bounded from below by the maximal integer k such that $|B| > (k-1)c(d)\varepsilon^{-d}$, i.e. $\lfloor |B|\varepsilon^d/c(d) \rfloor > k-1$. Hence, $s = |\tilde{B}| \geq \lfloor |B|\varepsilon^d/c(d) \rfloor$. By the above observations, \tilde{B} fulfills the desired properties.

Using \tilde{B} and independence, we have

$$\begin{aligned} \mathbb{P}(F_B) &= 1 - \mathbb{P}(\cap_{x \in B} \{T_x^{(k_*)} \leq \alpha/100, T_{x_*}^{(k_*)} \leq \alpha/100\}^c) \\ &\geq 1 - \mathbb{P}(\cap_{x \in \tilde{B}} \{T_x^{(k_*)} \leq \alpha/100, T_{x_*}^{(k_*)} \leq \alpha/100\}^c) \\ &= 1 - \prod_{x \in \tilde{B}} (1 - \mathbb{P}(T_x^{(k_*)} \leq \alpha/100)\mathbb{P}(T_{x_*}^{(k_*)} \leq \alpha/100)) \\ &= 1 - (1 - \gamma^2)^{|\tilde{B}|}. \end{aligned} \tag{5.52}$$

As a byproduct of (5.49), (5.50), (5.51) and (5.52) and finally using (5.47) in Lemma 5.6.3 we get

$$\begin{aligned} \mathbb{P}(G | H) &\geq \sum_{\substack{B \subset \partial R \cap B(n): \\ |B| > t}} \mathbb{P}(V_R = B) \left(1 - (1 - \gamma^2)^{|\tilde{B}|}\right) \\ &\geq \left(1 - (1 - \gamma^2)^{t\varepsilon^d/c(d)-1}\right) \sum_{\substack{B \subset \partial R \cap B(n): \\ |B| > t}} \mathbb{P}(V_R = B) \\ &= \left(1 - (1 - \gamma^2)^{t\varepsilon^d/c(d)-1}\right) \mathbb{P}(|V_R| > t) \\ &\geq \left[1 - (1 - \gamma^2)^{t\varepsilon^d/c(d)-1}\right] \left[1 - (1 - p)^{-t}\eta\right]. \end{aligned} \tag{5.53}$$

Finally, using (5.45) we conclude the proof of Lemma 5.6.1.

5.6.2 Proof of Lemma 5.6.3

Suppose that $B(m) \leftrightarrow K(m, n)$ in $B(n)$ for \mathbb{G} . Take a path (x_0, x_1, \dots, x_k) from $B(m)$ to $K(m, n)$ inside \mathbb{G} with all vertexes x_i in $B(n)$. Recall that $K(m, n) \subset T(n)$ and $R \cup \partial R$ is disjoint from $T(n)$ by (5.41). In particular, $R \cup \partial R$ is disjoint from $K(m, n)$. Since $B(m) \subset R$, the path starts at R . Let x_r be the last point of the path contained in R . Since R is disjoint from $K(m, n)$ and $x_k \in K(m, n)$, it must be $r < k$. Necessarily, $x_{r+1} \in \partial R$. Call x_ℓ the last point of the path contained in ∂R . It must be $\ell < k$ since ∂R is disjoint from $K(m, n) \ni x_k$. We claim that $x_\ell \in V_R$ and $A_{x_\ell} < +\infty$. To prove our claim we observe that the last property follows from the fact that all points x_0, x_1, \dots, x_k are in \mathbb{V} . Recall that these points are also in $B(n)$. Hence $x_\ell \in \partial R \cap B(n)$. Since $\{x_\ell, x_{\ell+1}\} \in \mathbb{E}$, we have $|x - y| + 2A_y \leq 1 - 2\alpha$ with $x := x_\ell$ and $y := x_{\ell+1}$. Finally, it remains to observe that $(x_{\ell+1}, \dots, x_k)$ is a path connecting $x_{\ell+1}$ to $x_k \in K(m, n)$ in $B(n) \setminus (R \cup \partial R)$ for \mathbb{G} . Hence, $x_\ell \in V_R$.

5.7 The sets $E[C, B, B', i]$ and $F[C, B, B', i]$

We have proved that if $B(m) \leftrightarrow K(m, n)$ in $B(n)$ for \mathbb{G} , then V_R contains at least a vertex of \mathbb{V} . As a byproduct with (5.24) (see the first paragraph of Subsection 5.6.1) we therefore have

$$\eta > \mathbb{P}(B(m) \not\leftrightarrow K(m, n) \text{ in } B(n) \text{ for } \mathbb{G}) \geq \mathbb{P}(V_R \cap \mathbb{V} = \emptyset), \quad (5.54)$$

On the other hand, we can bound

$$\mathbb{P}(V_R \cap \mathbb{V} = \emptyset) \geq \mathbb{P}(V_R \cap \mathbb{V} = \emptyset, |V_R| \leq t). \quad (5.55)$$

Note that V_R and $(A_x)_{x \in \partial R}$ are independent (see Remark 5.6.4). Hence

$$\begin{aligned} \mathbb{P}(V_R \cap \mathbb{V} = \emptyset, |V_R| \leq t) &= \sum_{\substack{B \subset \partial R: \\ |B| \leq t}} \mathbb{P}(V_R = B, A_x = +\infty \forall x \in B) \\ &= \sum_{\substack{B \subset \partial R: \\ |B| \leq t}} \mathbb{P}(V_R = B) \mathbb{P}(A_x = +\infty \forall x \in B) \\ &= \sum_{\substack{B \subset \partial R: \\ |B| \leq t}} \mathbb{P}(V_R = B) (1-p)^{|B|} \\ &\geq \sum_{\substack{B \subset \partial R: \\ |B| \leq t}} \mathbb{P}(V_R = B) (1-p)^t = \mathbb{P}(|V_R| \leq t) (1-p)^t. \end{aligned} \quad (5.56)$$

By combining (5.54), (5.55) and (5.56) we get that $\eta \geq \mathbb{P}(|V_R| \leq t) (1-p)^t$, which is equivalent to (5.47).

5.7 The sets $E[C, B, B', i]$ and $F[C, B, B', i]$

In the next sections we will iteratively construct random subsets of $\varepsilon\mathbb{Z}^d$ sharing the property to be connected in \mathbb{G}_* . We isolate here the fundamental building procedure.

Definition 5.7.1. *Given three sets $C, B, B' \subset \varepsilon\mathbb{Z}^d$ and given $i \in \{1, 2, \dots, K\}$, we define the subsets $E, F \subset \varepsilon\mathbb{Z}^d$ as follows:*

- *E is given by the points z_1 in $(\partial C) \cap B$ such that $T_{z_1}^{(i)} \leq \alpha/100$ and there exists $z_0 \in C$ with $|z_0 - z_1| \leq 1 - 2\alpha$ and $T_{z_0}^{(i)} \leq \alpha/100$;*
- *F is given by the points $z \in B'$ such that there exists a path (z_2, \dots, z_k) inside \mathbb{G} where $z_k = z$, all points z_2, \dots, z_k are in $B' \setminus (C \cup \partial C)$ and $|z_1 - z_2| + 2A_{z_2} \leq 1 - 2\alpha$ for some $z_1 \in E$.*

To stress the dependence from C, B, B', i , we will also write $E[C, B, B', i]$ and $F[C, B, B', i]$.

Note that the sets E, F, C are disjoint.

Lemma 5.7.2. *Given sets $C, B, B' \subset \varepsilon\mathbb{Z}^d$ and an index $i \in \{1, 2, \dots, K\}$, we define $E := E[C, B, B', i]$ and $F := F[C, B, B', i]$. If $C \subset \mathbb{V}_*$ is connected in the graph $\mathbb{G}_* = (\mathbb{V}_*, \mathbb{E}_*)$, then the set $C' := C \cup E \cup F$ is contained in \mathbb{V}_* and is connected in the graph \mathbb{G}_* .*

Proof. Recall (5.12). If $z \in E$, then $T_z^{(i)} < +\infty$ and therefore $z \in \mathbb{V}_*$. If $z \in F$, then $z \in \mathbb{V}$ (by definition of F) and therefore $z \in \mathbb{V}_*$. This implies that $E, F \subset \mathbb{V}_*$, hence $C' \subset \mathbb{V}_*$.

Since C is connected in \mathbb{G}_* and since $\mathbb{G} \subset \mathbb{G}_*$ (in particular the string (z_2, \dots, z_k) appearing in the definition of F is a path in \mathbb{G}_*), to prove the connectivity of C' in \mathbb{G}_* it is enough to show the following:

- (i) if $z_0, z_1 \in \mathbb{V}_*$ satisfy $T_{z_0}^{(i)} \leq \alpha/100$, $T_{z_1}^{(i)} \leq \alpha/100$ and $|z_0 - z_1| \leq 1 - 2\alpha$, then $\{z_0, z_1\} \in \mathbb{E}_*$;
- (ii) if $z_1, z_2 \in \mathbb{V}_*$ satisfy $T_{z_1}^{(i)} \leq \alpha/100$ and $|z_1 - z_2| + 2A_{z_2} \leq 1 - 2\alpha$, then $\{z_1, z_2\} \in \mathbb{E}_*$.

Using the assumptions of Item (i) we get

$$\begin{aligned} & |z_1 - z_0| + 2 \max\{A_{z_1} \wedge \min_{1 \leq j \leq K} T_{z_1}^{(j)}, A_{z_0} \wedge \min_{1 \leq j \leq K} T_{z_0}^{(j)}\} \leq \\ & |z_1 - z_0| + 2 \max\{T_{z_1}^{(i)}, T_{z_0}^{(i)}\} \leq \\ & |z_1 - z_0| + 2T_{z_1}^{(i)} + 2T_{z_0}^{(i)} \leq 1 - 2\alpha + \alpha/50 + \alpha/50 < 1 - \alpha. \end{aligned} \tag{5.57}$$

Using the assumptions of Item (ii) we get

$$\begin{aligned} & |z_1 - z_2| + 2 \max\{A_{z_1} \wedge \min_{1 \leq j \leq K} T_{z_1}^{(j)}, A_{z_2} \wedge \min_{1 \leq j \leq K} T_{z_2}^{(j)}\} \leq \\ & |z_1 - z_2| + 2 \max\{T_{z_1}^{(i)}, A_{z_2}\} \leq \\ & |z_1 - z_2| + 2A_{z_2} + 2T_{z_1}^{(i)} \leq 1 - 2\alpha + \alpha/50 < 1 - \alpha. \end{aligned} \tag{5.58}$$

The thesis then follows from Definition 5.3.5. □

5.8 The success–events S_1 and S_2

From now on $\varepsilon' \in (0, 1)$ is fixed and we choose m, n as in Lemma 5.6.1.

Let e_1, e_2, \dots, e_d be the canonical basis of \mathbb{R}^d . We denote by L_1, L_2, L_3, L_4 the isometries of \mathbb{R}^d given respectively by $\mathbf{I}, \theta, \theta^2, \theta^3$, where \mathbf{I} is the identity and θ is the unique rotation such that

$$\theta(e_1) = e_2 \quad \theta(e_2) = -e_1, \quad \theta(e_i) = e_i \text{ for all } i = 3, \dots, 2d. \tag{5.59}$$

We define $B'_1 \subset \varepsilon\mathbb{Z}^d$ as

$$B'_1 := B(n) \cup \left(\bigcup_{j=1}^4 L_j(T(m, n)) \right). \tag{5.60}$$

We call $K^{(j)}(m, n)$ the random set of points defined similarly for $K(m, n)$ but with $T(m, n)$ and $T(n)$ replaced by $L_j(T(m, n))$ and $L_j(T(n))$, respectively.

Definition 5.8.1. *We define S_1 as the success-event that $B(m)$ is a seed. We define C_2 as the set of points $x \in B'_1$ such that*

$$\{x\} \leftrightarrow B(m) \text{ in } B'_1 \text{ for } \mathbb{G}.$$

Furthermore, we denote by S_2 the success–event that C_2 contains a point of $K^{(j)}(m, n)$ for each $j = 1, 2, 3, 4$.

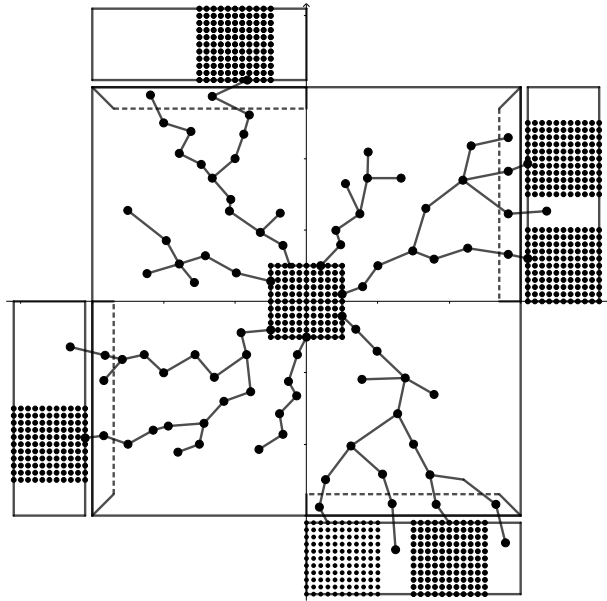

Figure 5.5. The set C_2 when the success–event S_2 occurs.

We refer to Fig. 5.5 for an example of the set C_2 when S_2 occurs.

Remark 5.8.2. *If the event S_1 occurs, then C_2 is a connected subset of \mathbb{G} (and therefore of \mathbb{G}_*) by Lemma 5.4.5.*

We note that the event S_1 implies that $B(m) \subset \mathbb{V}$, hence $B(m) \subset C_2$.

Lemma 5.8.3. *Given $B(m) \subset R \subset B'_1$, the event $S_1 \cap \{C_2 = R\}$ is determined by the random variables $\{A_x\}_{x \in R \cup \partial R}$.*

Proof. The claim is trivially true for S_1 . It is therefore enough to show that, if S_1 takes place, then the event $\{C_2 = R\}$ is equivalent to the following: (i) for any $x \in R$ there is a path from x to $B(m)$ inside R for \mathbb{G} and (ii) any $x \in \partial R \cap B'_1$ is not directly connected to R in \mathbb{G} , i.e. there is no $y \in R$ such that $\{x, y\} \in \mathbb{E}$. In fact, trivially the event $\{C_2 = R\}$ implies (i) and (ii). On the other hand, let us suppose that (i) and (ii) are satisfied (in addition to S_1). Then (i) implies that $R \subset C_2$. Take, by contradiction, $x \in C_2 \setminus R$. By definition of C_2 there exists a path from x to $B(m)$ in B'_1 for \mathbb{G} . Since $x \notin R$ and $B(m) \subset R$, there exists a last point x' in R^c visited by the path. Since the path ends in $B(m) \subset R$, after x' the path visits another point y which must belong to R . Hence we have $\{x', y\} \in \mathbb{E}$ (and therefore $x' \in \partial R \cap B'_1$) and $y \in R$, thus contradicting (ii). \square

Lemma 5.8.4. *It holds $\mathbb{P}(S_2|S_1) \geq 1 - 4\varepsilon'$.*

Proof. Since S_0 and S_1 are increasing events w.r.t. \preceq , by the FKG inequality (see Section 5.3) we have $\mathbb{P}(S_2|S_1) \geq \mathbb{P}(S_2)$. To show that $\mathbb{P}(S_2) \geq 1 - 4\varepsilon'$, we note that the event $F_j := \{B(m) \leftrightarrow K^{(j)}(m, n) \text{ in } B(n) \text{ for } \mathbb{G}\}$ implies that C_2 contains a point of $K^{(j)}(m, n)$. Hence, $\cap_{j=1}^4 F_j \subset S_2$ and therefore (see Remark 5.6.2) $\mathbb{P}(S_2^c) \leq \mathbb{P}\left(\cup_{j=1}^4 F_j^c\right) \leq 4\varepsilon'$. \square

5.9 The success-event S_3

As $2m < n$ and $2m|n$, we have $n \geq 4m$ and therefore $n - m \geq 3m > 2$.

If the event S_2 takes place, we define $b^{(1)}$ as the minimal (w.r.t. the lexicographic order) point z in $\varepsilon\mathbb{Z}^d$ such that $B(z, m)$ is a seed contained in $C_2 \cap T(m, n)$. Let us show that the definition is well posed, i.e. there is some seed $B(z, m) \subset C_2 \cap T(m, n)$. The event S_2 implies that C_2 contains a point $x \in K(m, n)$, hence there is some seed $B(z, m) \subset T(m, n)$ such that x is directly connected in \mathbb{G} to $B(z, m)$. By Lemma 5.4.5 we get that x is connected in \mathbb{G} to all points of $B(z, m)$. Since $x \in C_2$, we conclude that $B(z, m)$ is a seed contained in $C_2 \cap T(m, n)$.

If S_2 does not take place, we set $b^{(1)} := 0$ (just to complete the definition, this case will be irrelevant). We define

$$T^*(m, n) := f(T(m, n)) \text{ and } T^*(n) := f(T(n)), \quad (5.61)$$

where $f : \mathbb{R}^d \rightarrow \mathbb{R}^d$ is the isometry $f(x_1, x_2, \dots, x_d) := (x_1, -x_2, \dots, -x_d)$ (see Fig. 5.1).

Let $K^*(m, n)$ be defined as the set of points x in $b^{(1)} + T^*(n)$ which are directly connected inside \mathbb{G} to a seed contained in $b^{(1)} + T^*(m, n)$. We set $B'_2 := b^{(1)} + (B(n) \cup T^*(m, n))$.

Definition 5.9.1. We define the sets E_2, F_2 and C_3 as

$$\begin{aligned} E_2 &:= E[C_2, b^{(1)} + B(n), B'_2, 1], \\ F_2 &:= F[C_2, b^{(1)} + B(n), B'_2, 1], \\ C_3 &:= C_2 \cup E_2 \cup F_2. \end{aligned}$$

Moreover, we call S_3 the success-event that C_3 contains at least one vertex inside $K^*(m, n)$.

Note that C_2, E_2, F_2 are disjoint sets and that $C_3 \subset B'_1 \cup B'_2$. We refer to Fig. 5.6 for an example of the set C_3 when S_3 occurs.

Remark 5.9.2. If the event $S_1 \cap S_2$ occurs, then C_3 is a connected subset of \mathbb{G}_* by Lemma 5.7.2 and Remark 5.8.2.

Lemma 5.9.3. $\mathbb{P}(S_3|S_1, S_2) \geq 1 - \varepsilon'$.

Proof. We can write

$$\mathbb{P}(S_3|S_1, S_2) = \sum_{R, \tilde{b}} \mathbb{P}(S_3|S_1, S_2, C_2 = R, b^{(1)} = \tilde{b}) \mathbb{P}(C_2 = R, b^{(1)} = \tilde{b}|S_1, S_2), \quad (5.62)$$

where in the above sum $R \subset \varepsilon\mathbb{Z}^d$ and $\tilde{b} \in \varepsilon\mathbb{Z}^d$ are taken such that $\mathbb{P}(C_2 = R, b^{(1)} = \tilde{b}|S_1 \cap S_2) > 0$. Note that $B(m) \subset R \subset B'_1$ and $B(\tilde{b}, m) \subset R \cap T(m, n)$ (cf. (5.60)). Hence we have $(R \cup \partial R) \subset (B'_1 \cup \partial B'_1)$. We point out that, given $x \in B'_1 \cup \partial B'_1$, it must be $x_1 \leq n + \varepsilon + 2m + 1 - 2\alpha$. On the other hand, given $x \in \tilde{b} + (T^*(n) \cup T^*(m, n))$,

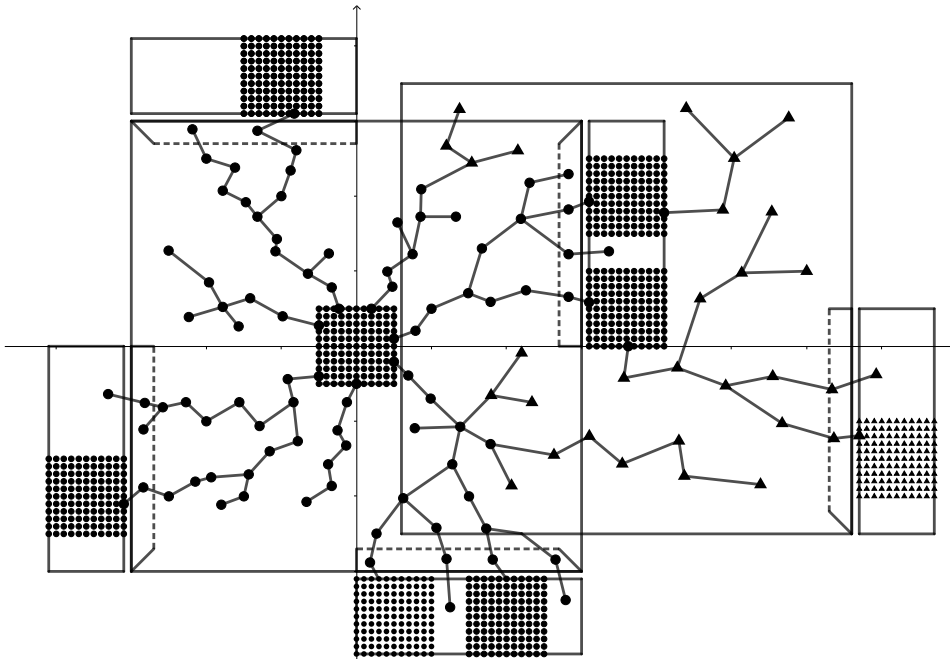

Figure 5.6. The set C_3 when the success-event S_3 occurs. Points in C_2 correspond to circles, while points in $C_3 \setminus C_2$ correspond to triangles.

it must be $x_1 \geq 2n + m + \varepsilon - 1$. Since $n > m + 2$, x cannot belong to both sets. In particular, we have

$$\begin{cases} B(\tilde{b}, m) \subset R, \\ (R \cup \partial R) \cap (\tilde{b} + (T^*(n) \cup T^*(m, n))) = \emptyset. \end{cases} \quad (5.63)$$

Due to (5.63) and Lemma 5.9.4 below, we can therefore apply Lemma 5.6.1 with \tilde{b} as new origin and with $\Lambda(x) := \emptyset$ for any $x \in R \cup \partial R$. and $k_* := 1$. By Lemma 5.9.5 below and Lemma 5.6.1 we get that

$$\mathbb{P}(S_3|H) \geq \mathbb{P}(G|H) \geq 1 - \varepsilon'. \quad (5.64)$$

The above bound and (5.62) imply that $\mathbb{P}(S_3|S_1, S_2) \geq 1 - \varepsilon'$. \square

Lemma 5.9.4. *The event*

$$H := S_1 \cap S_2 \cap \{C_2 = R\} \cap \{b^{(1)} = \tilde{b}\}$$

belongs to the σ -algebra generated by $\{A_x\}_{x \in R \cup \partial R}$.

Proof. As already observed, $B(m) \subset R \subset B'_1$ and $B(\tilde{b}, m) \subset R \cap T(m, n)$. Due to Lemma 5.8.3, the event $S_1 \cap \{C_2 = R\}$ is determined by $\{A_x\}_{x \in R \cup \partial R}$. If the event $S_1 \cap \{C_2 = R\}$ takes place, then the event $S_2 \cap \{b^{(1)} = \tilde{b}\}$ becomes equivalent to the following:

1. $B(\tilde{b}, m)$ is a seed;

2. if $B(z, m) \subset R \cap T(m, n)$ and z is lexicographically smaller than \tilde{b} , then $B(z, m)$ is not a seed;
3. the set $R \cap L_j(T(m, n))$ contains a seed for any $j = 2, 3, 4$.

The above properties (1), (2), (3) can be checked when knowing $\{A_x\}_{x \in R \cup \partial R}$. \square

Lemma 5.9.5. *The event G in Lemma 5.6.1, with $B(n)$ replaced by $B(\tilde{b}, n)$ and $K(m, n)$ replaced by $K^*(m, n)$, satisfies*

$$G \cap H \subset S_3 \cap H.$$

Proof. Let us suppose that $G \cap H$ takes place. Let (P1), ..., (P8) be the properties entering in the definition of G in Lemma 5.6.1, when replacing $B(n)$ and $K(m, n)$ by $B(\tilde{b}, n)$ and $K^*(m, n)$, respectively. To get the thesis it is enough to show that $z_\ell \in C_3$ since $z_\ell \in K^*(m, n)$ by (P5). Note that by H , (P1), (P2), (P6) and (P7) we have that $z_0 \in C_2$ and $z_1 \in E_2$, while by H , (P3), (P4) and (P8) we get that $z_2, \dots, z_\ell \in F_2$. Since $C_3 := C_2 \cup E_2 \cup F_2$, we have that $z_\ell \in C_3$. \square

5.10 The success-event S_4

If the event S_2 takes place, we define $b^{(2)}$ as the minimal (w.r.t. the lexicographic order) point z in $\varepsilon\mathbb{Z}^d$ such that $B(z, m)$ is a seed contained in $C_2 \cap L_2(T(m, n))$. The existence of such a seed is proved by the same arguments presented at the beginning of Section 5.9. If S_2 does not take place, we set $b^{(2)} := 0$ (just to complete the definition, this case will be irrelevant).

Recall the definition (5.61) of $T^*(n)$ and $T^*(m, n)$. We define $K_2^*(m, n)$ as the set of points of $b^{(2)} + L_2(T^*(n))$ which are directly connected inside \mathbb{G} to a seed contained in $b^{(2)} + L_2(T^*(m, n))$.

We set $B'_3 := b^{(2)} + (B(n) \cup L_2(T^*(m, n)))$.

Definition 5.10.1. *We define the sets E_3, F_3 and C_4 as*

$$\begin{aligned} E_3 &:= E[C_3, b^{(2)} + B(n), B'_3, 2], \\ F_3 &:= F[C_3, b^{(2)} + B(n), B'_3, 2], \\ C_4 &:= C_3 \cup E_3 \cup F_3. \end{aligned}$$

Moreover, we call S_4 the success-event that C_4 contains at least one vertex inside $K_2^*(m, n)$.

Note that C_3, E_3, F_3 are disjoint sets and $C_4 \subset B'_1 \cup B'_2 \cup B'_3$. We refer to Fig. 5.7 for an example of the set C_4 when S_4 occurs.

Remark 5.10.2. *If the event $S_1 \cap S_2$ occurs, then C_4 is a connected subset of \mathbb{G}_* by Lemma 5.7.2 and Remark 5.9.2.*

Lemma 5.10.3. $\mathbb{P}(S_4 | S_1, S_2, S_3) \geq 1 - \varepsilon'$.

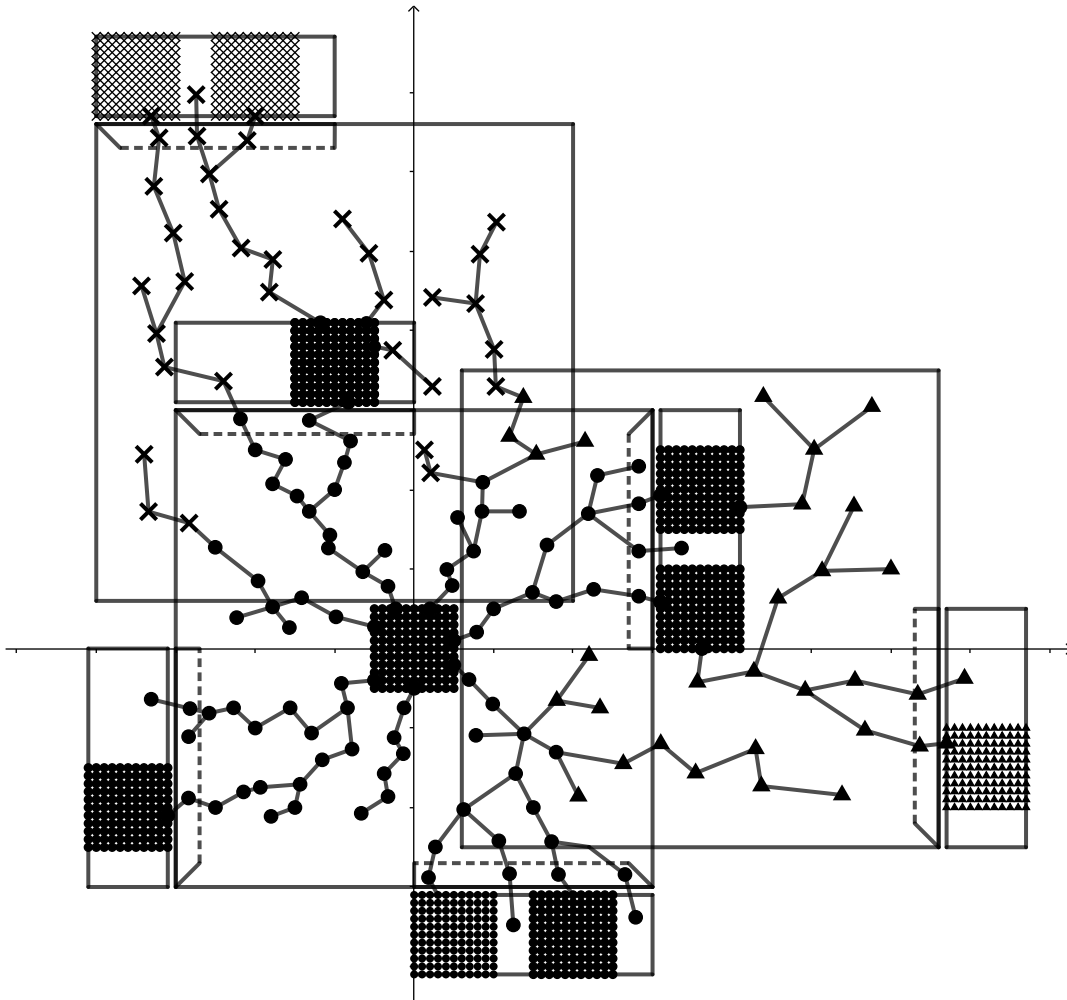

Figure 5.7. The set C_4 when the success-event S_4 occurs. Points in C_2 , $C_3 \setminus C_2$ and $C_4 \setminus C_3$ correspond to circles, triangles and crosses, respectively.

Proof. Given $R_2, R_3 \subset \varepsilon\mathbb{Z}^d$ and $\tilde{b}_1, \tilde{b}_2 \in \varepsilon\mathbb{Z}^d$, define the events $S_{123} := S_1 \cap S_2 \cap S_3$ and

$$H := S_{123} \cap \{C_2 = R_2\} \cap \{C_3 = R_3\} \cap \{b^{(1)} = \tilde{b}_1\} \cap \{b^{(2)} = \tilde{b}_2\}. \quad (5.65)$$

We can write

$$\begin{aligned} \mathbb{P}(S_4 | S_{123}) &= \sum_{R_1, R_2, \tilde{b}_1, \tilde{b}_2} \mathbb{P}(S_4 | H) \mathbb{P}(C_3 = R_3, b^{(2)} = \tilde{b}_2 | S_{123}, C_2 = R_2, b^{(1)} = \tilde{b}_1) \\ &\quad \times \mathbb{P}(C_2 = R_2, b^{(1)} = \tilde{b}_1 | S_{123}), \end{aligned} \quad (5.66)$$

where in the above sum $R_2, R_3 \subset \varepsilon\mathbb{Z}^d$ and $\tilde{b}_1, \tilde{b}_2 \in \varepsilon\mathbb{Z}^d$ are taken such that

$$\mathbb{P}(C_3 = R_3, b^{(2)} = \tilde{b}_2 | S_{123}, C_2 = R_2, b^{(1)} = \tilde{b}_1) \mathbb{P}(C_2 = R_2, b^{(1)} = \tilde{b}_1 | S_{123}) > 0. \quad (5.67)$$

The above inequality implies that $R_2 \subset R_3 \subset B'_1 \cup B'_2$ and that $B(\tilde{b}_2, m) \subset R_2 \cap L_2(T(m, n))$. As a consequence, $(R_3 \cup \partial R_3) \subset (B'_1 \cup \partial B'_1 \cup B'_2 \cup \partial B'_2)$. We point out that, given $x \in B'_1 \cup \partial B'_1 \cup B'_2 \cup \partial B'_2$, it must be $x_2 \leq n + \varepsilon + 2m + 1 - 2\alpha$. On the other hand, given $x \in \tilde{b}_1 + (L_2(T^*(n)) \cup L_2(T^*(m, n)))$, it must be $x_2 \geq 2n + m + \varepsilon - 1$. Since $n > m + 2$, x cannot belong to both sets. In particular, we have

$$\begin{cases} B(\tilde{b}_2, m) \subset R_3, \\ (R_3 \cup \partial R_3) \cap (\tilde{b}_2 + (L_2(T^*(n)) \cup L_2(T^*(m, n)))) = \emptyset. \end{cases} \quad (5.68)$$

Due to (5.68) and Lemma 5.10.4 below, we can therefore apply Lemma 5.6.1 with $R := R_3$ (by taking \tilde{b}_2 as origin there) with

$$\Lambda(x) := \begin{cases} \emptyset & \text{if } x \in (R_3 \cup \partial R_3) \setminus B(\tilde{b}_1, n + 1), \\ 1 & \text{if } x \in (R_3 \cup \partial R_3) \cap B(\tilde{b}_1, n + 1), \end{cases} \quad (5.69)$$

and $k_* := 2$. Lemma 5.10.6 below and Lemma 5.6.1 imply that

$$\mathbb{P}(S_4 | H) \geq \mathbb{P}(G | H) \geq 1 - \varepsilon'. \quad (5.70)$$

The above bound and (5.66) imply that $\mathbb{P}(S_4 | S_1, S_2, S_3) \geq 1 - \varepsilon'$. \square

Lemma 5.10.4. *The event H in (5.65) belongs to the σ -algebra generated by $\{A_x\}_{x \in R_3 \cup \partial R_3}$ and $\{T_x^{(1)}\}_{x \in R_3 \cup \partial R_3}$.*

Proof. We call \mathcal{F} the σ -algebra generated by $\{A_x\}_{x \in R_3 \cup \partial R_3}$ and $\{T_x^{(1)}\}_{x \in R_3 \cup \partial R_3}$. Due to Lemma 5.9.4 the event $D_1 := S_1 \cap S_2 \cap \{C_2 = R_2\} \cap \{b^{(1)} = \tilde{b}_1\}$ belongs to the σ -algebra generated by $\{A_x\}_{x \in R_2 \cup \partial R_2}$, which is included in \mathcal{F} since $R_2 \subset R_3$. Hence, it remains to prove that, if the event D_1 takes place, then the event $D_2 := S_3 \cap \{C_3 = R_3\} \cap \{b^{(2)} = \tilde{b}_2\}$ is determined when knowing $\{A_x\}_{x \in R_3 \cup \partial R_3}$ and $\{T_x^{(j)}\}_{x \in R_3 \cup \partial R_3, j \in \Lambda(x)}$.

By writing D_2 as a suitable union of sets, it is enough to prove the same for the event $D_3 := D_2 \cap \{E_2 = \tilde{E}_2\} \cap \{F_2 = \tilde{F}_2\}$, where \tilde{E}_2 and \tilde{F}_2 are subsets of $\varepsilon\mathbb{Z}^d$ such that $\tilde{E}_2 \subset (\partial R_2) \cap (\tilde{b}_1 + B(n))$, $\tilde{F}_2 \subset B'_2 \setminus (R_2 \cup \partial R_2)$ and $\{R_2, \tilde{E}_2, \tilde{F}_2\}$ is a partition of R_3 .

Claim 5.10.5. $D_1 \cap D_3 = D_1 \cap \{\text{Items (1),...,(7) are fulfilled}\}$, where

1. $B(\tilde{b}_2, m)$ is a seed;
2. if $B(z, m) \subset R_2 \cap L_2(T(m, n))$ and z is lexicographically smaller than \tilde{b}_2 , then $B(z, m)$ is not a seed;
3. \tilde{E}_2 is given by the points $z_1 \in (\partial R_2) \cap (\tilde{b}_1 + B(n))$ with $T_{z_1}^{(1)} \leq \alpha/100$ for which there exists $z_0 \in R_2$ with $|z_0 - z_1| \leq 1 - 2\alpha$ and $T_{z_0}^{(1)} \leq \alpha/100$;
4. for any points $z \in \tilde{F}_2$ there exists a path (z_2, z_3, \dots, z_k) inside \mathbb{G} where $z_k = z$, all points z_2, \dots, z_k are in \tilde{F}_2 and $|z_1 - z_2| + 2A_{z_2} \leq 1 - 2\alpha$ for some $z_1 \in \tilde{E}_2$;
5. if $z_1 \in \tilde{E}_2$ and $z_2 \in \partial\{z_1\}$ satisfy $z_2 \in B'_2 \setminus (R_2 \cup \partial R_2)$ and $|z_1 - z_2| + 2A_{z_2} \leq 1 - 2\alpha$, then $z_2 \in \tilde{F}_2$;
6. any $x \in \partial\tilde{F}_2$ with $x \in B'_2 \setminus (R_2 \cup \partial R_2)$ is not directly connected to \tilde{F}_2 in \mathbb{G} ;
7. there exist $x \in R_3 \cap (\tilde{b}_1 + T^*(n))$ and $z \in \varepsilon\mathbb{Z}^d$ and $y \in B(z, m)$ such that $B(z, m) \subset (\tilde{b}_1 + T^*(m, n)) \cap R_3$, $B(z, m)$ is a seed and $\{x, y\} \in \mathbb{E}$.

Proof of Claim 5.10.5. Let us prove the above claim. One direction is immediate: if $D_1 \cap D_3$ is verified, then the above Items (1),..., (7) are fulfilled.

Suppose that D_1 and also Items (1),..., (7) are fulfilled.

- Since $C_2 = R_2$ by the event D_1 and since $B(\tilde{b}_2, m) \subset R_2 \cap L_2(T(m, n))$ (as already observed in the proof of Lemma 5.10.3), Items (1) and (2) imply that $b^{(2)} = \tilde{b}_2$.

- Since $C_2 = R_2$ by the event D_1 , Item (3) implies that $E_2 = \tilde{E}_2$.

- We now prove that $F_2 = \tilde{F}_2$. As we know that $C_2 = R_2$ and $E_2 = \tilde{E}_2$, Item (4) implies that $\tilde{F}_2 \subset F_2$. Suppose that there exists $z \in F_2 \setminus \tilde{F}_2$. Then there exists a path (z_2, z_3, \dots, z_k) inside \mathbb{G} where $z_k = z$, all points z_2, \dots, z_k are in $B'_2 \setminus (R_2 \cup \partial R_2)$ and $|z_1 - z_2| + 2A_{z_2} \leq 1 - 2\alpha$ for some $z_1 \in \tilde{E}_2$ (we have used the definition of F_2 and that $C_2 = R_2$ and $E_2 = \tilde{E}_2$). As $|z_1 - z_2| \leq 1 - 2\alpha$, we have that $z_2 \in \partial\{z_1\}$ and therefore Item (5) implies that $z_2 \in \tilde{F}_2$. Let r be the maximal integer $2 \leq r \leq k$ such that $z_r \in \tilde{F}_2$. Since by hypothesis $z = z_k \in F_2 \setminus \tilde{F}_2$, it must be $r < k$. Let us now focus on z_{r+1} . By the maximality of r it holds $z_{r+1} \notin \tilde{F}_2$. Since $\{z_r, z_{r+1}\} \in \mathbb{E}$ we have that $z_{r+1} \in \partial\tilde{F}_2$. Since we already know that $z_{r+1} \in B'_2 \setminus (R_2 \cup \partial R_2)$, we arrive to a contradiction of Item (6). As a consequence, it must be $F_2 = \tilde{F}_2$.

- Since $C_3 = C_2 \cup E_2 \cup F_2$ and at this point we know that $C_2 = R_2$, $E_2 = \tilde{E}_2$, $F_2 = \tilde{F}_2$, we conclude that $C_3 = R_3$ (recall that $\{R_2, \tilde{E}_2, \tilde{F}_2\}$ is a partition of R_3).

- To conclude that the event D_3 is fulfilled, it remains to prove that the success-event S_3 is verified. As we have proved that $C_3 = R_3$, Item (7) implies S_3 . \square

As $B(\tilde{b}_2, m) \subset R_2 \subset R_3$, $\tilde{E}_2 \subset R_3$ and $\tilde{F}_2 \subset R_3$, the validity of Items (1),..., (7) is determined by knowing $\{A_x\}_{x \in R_3 \cup \partial R_3}$ and $\{T_x^{(j)}\}_{x \in R_3 \cup \partial R_3, j \in \Lambda(x)}$. \square

Lemma 5.10.6. *The event G in Lemma 5.6.1, with $B(n)$ replaced by $B(\tilde{b}_2, n)$, $K(m, n)$ replaced by $K_2^*(m, n)$ and R replaced by R_3 , satisfies*

$$G \cap H \subset S_4 \cap H.$$

Proof. Let us suppose that $G \cap H$ takes place. Let (P1),..., (P8) be the properties entering in the definition of G in Lemma 5.6.1, when replacing $B(n)$ by $B(\tilde{b}_2, n)$, $K(m, n)$ by $K_2^*(m, n)$ and R by R_3 , respectively. To get the thesis it is enough to show that $z_\ell \in C_4$ since $z_\ell \in K_2^*(m, n)$ by (P5). Note that by H , (P1), (P2), (P6) and (P7) we have that $z_0 \in C_3$ and $z_1 \in E_3$, while by H , (P3), (P4) and (P8) we get that $z_2, \dots, z_\ell \in F_3$. Since $C_4 := C_3 \cup E_3 \cup F_3$, we have that $z_\ell \in C_4$. \square

5.11 The success-events S_5, S_6 and the occupation of $B(N)$

Recall the definition of the isometry L_j given at the beginning of Section 5.8. Fix $i = 5, 6$. If the event S_2 takes place, we define $b^{(i-2)}$ as the minimal (w.r.t. the lexicographic order) point z in $\varepsilon\mathbb{Z}^d$ such that $B(z, m)$ is a seed contained in $C_2 \cap L_{i-2}(T(m, n))$. If S_2 does not take place, we set $b^{(i-2)} := 0$.

We define $K_{i-2}^*(m, n)$ as the set of points x in $b^{(i-2)} + L_{i-2}(T^*(n))$ which are directly connected inside \mathbb{G} to a seed contained in $b^{(i-2)} + L_{i-2}(T^*(m, n))$. We set $B'_{i-1} := b^{(i-2)} + (B(n) \cup L_{i-2}(T^*(m, n)))$ and we define $E_4, F_4, C_5, S_5, E_5, F_5, C_6, S_6$ as follows.

Definition 5.11.1. For $i = 5$ and afterwards for $i = 6$, we define the sets E_{i-1}, F_{i-1} and C_i as

$$\begin{aligned} E_{i-1} &:= E[C_{i-1}, b^{(i-2)} + B(n), B'_{i-1}, i-2], \\ F_{i-1} &:= F[C_{i-1}, b^{(i-2)} + B(n), B'_{i-1}, i-2], \\ C_i &:= C_{i-1} \cup E_{i-1} \cup F_{i-1}. \end{aligned}$$

Moreover, we call S_i the success-event that C_i contains at least one vertex inside $K_{i-2}^*(m, n)$.

Note that $C_{i-1}, E_{i-1}, F_{i-1}$ are disjoint sets and $C_i \subset \cup_{k=1}^{i-1} B'_k$.

Remark 5.11.2. If the event $S_1 \cap S_2$ occurs, then C_5, C_6 are connected subsets of \mathbb{G}_* . This can be proved by induction using Lemma 5.7.2 and Remark 5.10.2.

In order to define objects once and for all, given $j \geq 2$ and given sets R_2, R_3, \dots, R_j and points $\tilde{b}_1, \tilde{b}_2, \dots, \tilde{b}_{j-1}$ we set

$$H_j := \left(\bigcap_{k=1}^j S_k \right) \cap \left(\bigcap_{k=2}^j \{C_k = R_k\} \right) \cap \left(\bigcap_{k=1}^{j-1} \{b^{(k)} = \tilde{b}_k\} \right), \quad (5.71)$$

$$\Lambda_j(x) := \{k : 1 \leq k \leq j-2, x \in B(\tilde{b}_k, n+1)\}, \quad \forall x \in R_j \cup \partial R_j, \quad (5.72)$$

$$\mathcal{F}_j := \sigma \left(\{A_x\}_{x \in R_j \cup \partial R_j}, \{T_x^{(k)}\}_{x \in R_j \cup \partial R_j, k \in \Lambda_j(x)} \right). \quad (5.73)$$

Lemma 5.11.3. For $i = 5, 6$ it holds $\mathbb{P}(S_i | S_1, S_2, \dots, S_{i-1}) \geq 1 - \varepsilon'$.

The proof of the above lemma follows the same arguments used to prove Lemmata 5.9.3 and 5.10.3, hence it is omitted. We just make some comments, which will be useful in the sequel. Iteratively, one has to lower bound the conditional probability $\mathbb{P}(S_i | H_{i-1})$, where H_{i-1} is assumed to have positive probability. To this aim one has to apply Lemma 5.6.1 with $R := R_{i-1}$, $\Lambda(x) := \Lambda_{i-1}(x)$ and with $B(n), T(n)$ and

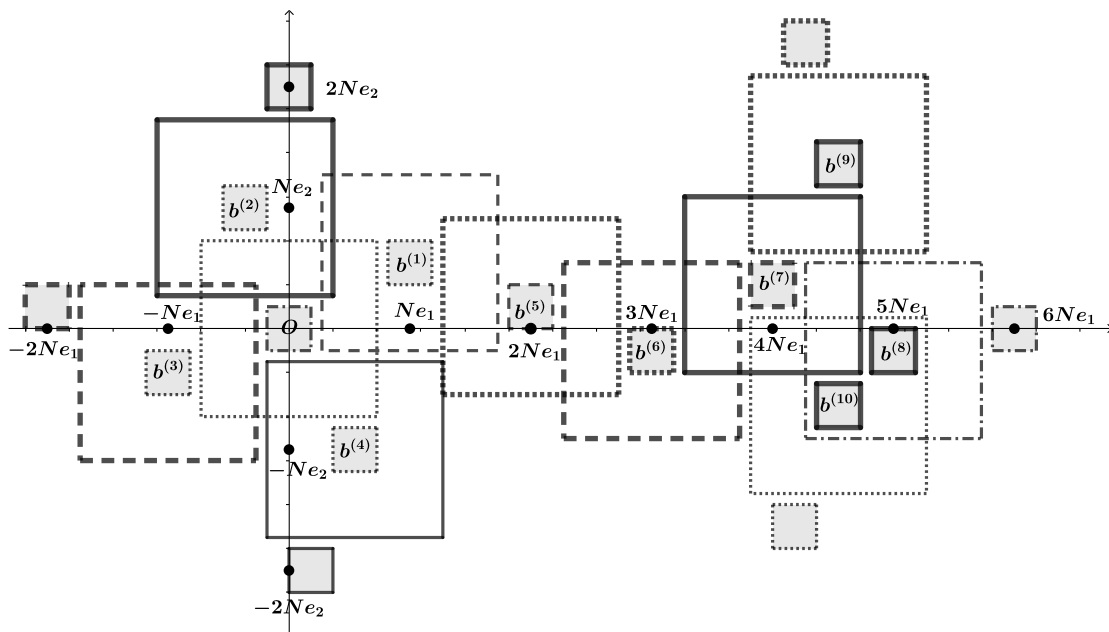

Figure 5.8. Colored small boxes are the seeds $B(m)$ and $B(b^{(i)}, m)$, while bigger boxes are given by $B(n)$ and $B(b^{(i)}, n)$.

$T(m, n)$ replaced by $B(\tilde{b}_{i-2}, n)$, $\tilde{b}_{i-2} + L_{i-2}(T^*(n))$ and $\tilde{b}_{i-2} + L_{i-2}(T^*(m, n))$. Part of the proof is to show that the event H_{i-1} belongs to the σ -algebra \mathcal{F}_{i-1} . This can be done by induction as in the proof of Lemma 5.10.4, observing that H_3 equals the event H in Lemma 5.10.4, hence the above property holds for H_3 and this would be the starting point of the induction. We point out that, when Lemma 5.6.1 is applied to lower bound $\mathbb{P}(S_i | H_{i-1})$, we fulfill condition (5.42) by taking $k_* := i - 2$.

Definition 5.11.4. Let $N := n + m + \varepsilon$. We say that the box $B(N)$ is occupied if the event $\cap_{i=1}^6 S_i$ takes place.

Proposition 5.11.5. $\mathbb{P}(B(N) \text{ is occupied} | S_1) \geq (1 - 4\varepsilon')(1 - \varepsilon')^4 \geq (1 - 8\varepsilon')$.

Proof. It is enough to apply Lemmata 5.8.4, 5.9.3, 5.10.3 and 5.11.3 and, at the end, Bernoulli's inequality. \square

5.12 The success events S_7, S_8

Recall that $N = n + m + \varepsilon$ and that e_1, e_2, \dots, e_d is the canonical basis of \mathbb{Z}^d . We will work in the renormalized lattice $4N\mathbb{Z}^d$.

Recall Definition 5.11.4 for the occupation of $B(N)$. Note that if $B(N)$ is occupied, then the set C_6 intersects the box $B(2Ne_1, N)$. Indeed (see Fig. 5.6) the success-event S_3 implies that C_3 contains a seed inside $(b^{(1)} + T^*(m, n))$ and $(b^{(1)} + T^*(m, n)) \subset B(2Ne_1, N)$, since

$$b_1^{(1)} = N, \quad b_i^{(1)} \in [m, n - m] \subset [-N, N] \quad (5.74)$$

and for all $x \in (b^{(1)} + T^*(m, n))$ the following items hold:

- $x_1 \in [b_1^{(1)} + n + \varepsilon, b_1^{(1)} + n + \varepsilon + 2m] = [2N - m, 2N + m] \subset (2N + [-N, N]);$
- for $i = 2, \dots, d$, $x_i \in [b_i^{(1)} - n, b_i^{(1)}] \subset [m - n, n - m] \subset [-N, N].$

As in [10] we extend the set C_6 in two steps, i.e. introducing the increasing sets C_7 and C_8 , in such a way that they intersect respectively $B(3Ne_1, N)$ and $B(4Ne_1, N)$ when both the two steps are successful. This will be done in Subsections 5.12.1 and 5.12.2 below.

In order to shorten the presentation, we will define geometric objects only in the successful cases relevant to continue the procedure (in the other cases, the definition can be chosen arbitrarily).

5.12.1 Linking $B(2Ne_1, N)$ to $B(3Ne_1, N)$

In what follows we assume that $B(N)$ is occupied, i.e. the event $\cap_{i=1}^6 S_i$ occurs. Since S_3 occurs, the cluster C_6 contains at least one seed in $b^{(1)} + T^*(m, n)$ and, by construction, this seed is contained in $B(2Ne_1, N)$. We define $b^{(5)}$ as the minimal point $z \in \varepsilon\mathbb{Z}^d$ such that $B(z, m)$ is a seed contained in $C_6 \cap (b^{(1)} + T^*(m, n))$. Let us call

$$T^{**}(m, n) := g\left(T(m, n)|b^{(5)}\right) \quad \text{and} \quad T^{**}(n) := g\left(T(n)|b^{(5)}\right),$$

where, given $a \in \mathbb{R}^d$, $g(\cdot|a) : \mathbb{R}^d \rightarrow \mathbb{R}^d$ is the isometry

$$g(x|a) := (x_1, -\text{sgn}(a_2)x_2, \dots, -\text{sgn}(a_d)x_d) \tag{5.75}$$

and $\text{sgn}(\cdot)$ is the sign function, with the convention that $\text{sgn}(0) = +1$. We point out that we need to use $T^{**}(m, n)$ instead of $T(m, n)$ or $T^*(m, n)$ to assure that, if this and the next two steps are successful, the new cluster C_6 intersects $B(4Ne_1, N)$. Let $K^{(5)}(m, n)$ be defined as the set of the points x in $b^{(5)} + T^{**}(n)$ which are directly connected inside \mathbb{G} to a seed contained in $b^{(5)} + T^{**}(m, n)$.

We define

$$B'_6 := b^{(5)} + (B(n) \cup T^{**}(m, n)).$$

Definition 5.12.1. *We define the sets E_6, F_6 and C_7 as*

$$\begin{aligned} E_6 &:= E[C_6, b^{(5)} + B(n), B'_6, 5], \\ F_6 &:= F[C_6, b^{(5)} + B(n), B'_6, 5], \\ C_7 &:= C_6 \cup E_6 \cup F_6. \end{aligned}$$

Moreover, we call S_7 the success-event that C_7 contains at least one vertex inside $K^{(5)}(m, n)$.

We claim that

$$\mathbb{P}(S_7 | S_1, S_2, \dots, S_6) \geq 1 - \varepsilon'. \tag{5.76}$$

Recall (5.71), (5.72) and (5.73). The proof of the above claim follows the same arguments used to prove Lemmata 5.9.3, 5.10.3 and 5.11.3. Hence we only specify the role of the relevant objects involved in the proof when we apply Lemma 5.6.1 and we show that the hypotheses of Lemma 5.6.1 are indeed satisfied. To prove

(5.76) we have to lower bound the conditional probability $\mathbb{P}(S_7 | H_6)$. To this aim we want to apply Lemma 5.6.1 with $R := R_6$, $\Lambda(x) := \Lambda_6(x)$ and with $B(n)$, $T(n)$ and $T(m, n)$ replaced by $B(\tilde{b}_5, n)$, $\tilde{b}_5 + T^{**}(n)$ and $\tilde{b}_5 + T^{**}(m, n)$, respectively. One has to apply the iterative method described after Lemma 5.11.3. In particular recall (5.71) and (5.73). One gets that $H_6 \in \mathcal{F}_6$ using that $H_5 \in \mathcal{F}_5$ (the last property was proved after Lemma 5.11.3).

We also note that (5.41) with $\tilde{b}_5 + T^{**}(n)$ and $\tilde{b}_5 + T^{**}(m, n)$ instead of $T(n)$ and $T(m, n)$, respectively, is satisfied. In fact, we have $\tilde{b}_5 + B(m) \subset R_6$ since we are supposing $\mathbb{P}(H_6) > 0$. To get that $\tilde{b}_5 + (T^{**}(n) \cup T^{**}(m, n))$ and $R_6 \cup \partial R_6$ are disjoint, we observe that $R_6 \cup \partial R_6 \subset \cup_{k=1}^5 (B'_k \cup \partial B'_k)$ and points in $\cup_{k=1}^5 (B'_k \cup \partial B'_k)$ have their first coordinate not bigger than $2N + m + 1$ (cf. Fig. 5.8). On the other hand, points in $\tilde{b}_5 + (T^{**}(n) \cup T^{**}(m, n))$ have their first coordinate not smaller than $2N + n + \varepsilon$, thus implying (5.41). Finally, note that condition (5.42) in Lemma 5.6.1 is satisfied if we take $k_* = 5$.

We conclude this subsection explaining why the above procedure builds a linking between $B(2Ne_1, N)$ and $B(3Ne_1, N)$. By construction C_7 contains at least a seed in $b^{(5)} + T^{**}(m, n)$. We claim that $b^{(5)} + T^{**}(m, n) \subset B(3Ne_1, N)$ (see Fig. 5.8). Indeed $b_1^{(5)} = b_1^{(1)} + N$, $b_i^{(5)} \in [b_i^{(1)} - n + m, b_i^{(1)} - m]$ for any $i = 2, \dots, d$ and hence by (5.74)

$$b_1^{(5)} = 2N, \quad b_i^{(5)} \in [2m - n, n - 2m] \subset [-N, N]. \quad (5.77)$$

So, for $x \in (b^{(5)} + T^{**}(m, n))$, we have (using (5.75) and (5.77))

- $x_1 \in [3N - m, 3N + m] \subset (3N + [-N, N])$;
- if $b_i^{(5)} \geq 0$ it follows that $x_i \in [b_i^{(5)} - n + m, b_i^{(5)} - m] \subset [-n + m, b_i^{(5)} - m] \subset [-n + m, n - 3m] \subset [-N, N]$;
- if $b_i^{(5)} < 0$ it follows that $x_i \in [b_i^{(5)} + m, b_i^{(5)} + n - m] \subset [-n + 3m, n - m] \subset [-N, N]$.

This proves that $(b^{(5)} + T^{**}(m, n)) \subset B(3Ne_1, N)$.

5.12.2 Linking $B(3Ne_1, N)$ to $B(4Ne_1, N)$.

Assume that the event $S_1 \cap S_2 \cap \dots \cap S_7$ occurs. We define $b^{(6)}$ as the minimal point in $\varepsilon\mathbb{Z}^d$ such that $B(z, m)$ is a seed contained in $C_7 \cap (b^{(5)} + T^{**}(m, n))$. Recall (5.75). We set

$$\tilde{T}(m, n) := g(T(m, n) | b^{(6)}) \text{ and } \tilde{T}(n) := g(T(n) | b^{(6)}),$$

$B'_7 := b^{(6)} + (B(n) \cup \tilde{T}(m, n))$ and we define $K^{(6)}(m, n)$ as the set of the points x in $b^{(6)} + \tilde{T}(n)$ which are directly connected inside \mathbb{G} to a seed contained in $b^{(6)} + \tilde{T}(m, n)$.

Definition 5.12.2. *We define the sets E_7, F_7 and C_8 as*

$$\begin{aligned} E_7 &:= E[C_7, b^{(6)} + B(n), B'_7, 6], \\ F_7 &:= F[C_7, b^{(6)} + B(n), B'_7, 6], \\ C_8 &:= C_7 \cup E_7 \cup F_7. \end{aligned}$$

Moreover, we call S_8 the success event that C_8 contains at least one vertex inside $K^{(6)}(m, n)$.

We claim that

$$\mathbb{P}(S_8 \mid S_1, S_2, \dots, S_7) \geq 1 - \varepsilon'. \quad (5.78)$$

Recall (5.71), (5.72), (5.73) and the arguments and notation presented just after Lemma 5.11.3. Again one has to apply Lemma 5.6.1 to lower bound $\mathbb{P}(S_8 \mid H_7)$, now taking $R := R_7$, $\Lambda(x) := \Lambda_7(x)$ and $B(n)$, $T(n)$ and $T(m, n)$ replaced respectively by $B(\tilde{b}_6, n)$, $\tilde{b}_6 + \tilde{T}(n)$ and $\tilde{b}_6 + \tilde{T}(m, n)$. By the discussion in Section 5.12.1 we have that $H_6 \in \mathcal{F}_6$. By iteration one gets that $H_7 \in \mathcal{F}_7$ (cf. the proof of Lemma 5.10.4). Hence, when applying Lemma 5.6.1, condition (5.42) is satisfied by taking $k_* = 6$.

Moreover note that the second condition (5.41) with $\tilde{b}_6 + \tilde{T}(n)$ and $\tilde{b}_6 + \tilde{T}(m, n)$ instead of $T(n)$ and $T(m, n)$, respectively, is satisfied. Indeed $R_7 \cup \partial R_7 \subset \cup_{k=1}^6 (B'_k \cup \partial B'_k)$ and points in $\cup_{k=1}^6 (B'_k \cup \partial B'_k)$ have their first coordinate not bigger than $3N + m + 1$. On the other hand, points in $\tilde{b}_6 + \tilde{T}(n) \cup \tilde{T}(m, n)$ have their first coordinate not smaller than $3N + n - 1$ and hence $\tilde{b}_6 + \tilde{T}(n) \cup \tilde{T}(m, n)$ and $R_7 \cup \partial R_7$ are disjoint, that is the second inclusion in (5.41) holds. Note also that the first condition in (5.41) is verified since $\tilde{b}_6 + B(m) \subset R_7$ when the event $\cap_{k=1}^7 S_k$ occurs.

5.13 Occupation of the box $B(4Ne_1, N)$ after being linked to $B(N)$

Warning 5.13.1. While in Section 5.8 we have defined L_1, L_2, L_3, L_4 as $\mathbb{I}, \theta, \theta^2, \theta^3$ (cf. (5.59)), respectively, in this section we set $L_1 := \mathbb{I}, L_2 := h \circ \theta, L_3 := \theta^3$, where $h(x) = (-x_1, x_2, \dots, x_d)$ if $x = (x_1, x_2, \dots, x_d)$.

Lemma 5.13.1. *The following holds:*

- (i) *The random variables $\{\{T_x^{(j)}\}_{x \in \varepsilon \mathbb{Z}^d} \mid j = 1, \dots, 4\}$ that have been considered during the construction of $\{C_i\}_{i=2}^6$, are all associated only with points $x \in B(2N + m + 1)$.*
- (ii) *The random variables $\{\{T_x^{(j)}\}_{x \in \varepsilon \mathbb{Z}^d} \mid j = 5, 6\}$ that have been considered during the construction of C_7 and C_8 , are all associated only with points $x \in \varepsilon \mathbb{Z}^d$ for which $x_1 \in [2N - n - 1, 4N + m + 1]$ and $x_j \in [-2N - 1, 2N + 1]$ for $j \geq 2$.*

The proof of the above lemma is based on straightforward but cumbersome computations and therefore it is omitted. On the other hand, the validity of the lemma is confirmed also by Figure 5.8.

Let us assume that the event $S_1 \cap \dots \cap S_8$ occurs. By construction C_8 contains at least a seed in $b^{(6)} + \tilde{T}(m, n)$. We define $b^{(7)}$ as minimal point in $\varepsilon \mathbb{Z}^d$ such that $B(z, m)$ is such a seed. The idea now is to connect the cluster C_8 to seeds lying on the remaining three faces of the cube $b^{(5)} + B(n + \varepsilon)$ in directions e_1 and $\pm e_2$. We want to extend the cluster in a way similar to the one used to construct C_2 , paying attention to some slight changes due to the information that we already know about the cluster that we have constructed. Indeed note that $b^{(7)}$ can differ from $4Ne_1$ and we have already connected $b^{(7)} + B(m)$ to the seed $b^{(6)} + B(m)$. For this reason, we

5.13 Occupation of the box $B(4Ne_1, N)$ after being linked to $B(N)$

connect $b^{(7)} + B(m)$ to seeds that have only points with first coordinate not smaller than $4N$. This necessity motivates the new definition of L_1, L_2, L_3 . Indeed, below we will connect $b^{(7)} + B(m)$ with a seed contained in $b^{(7)} + \hat{T}_j(m, n)$ for $j = 1, 2, 3$, where

$$\hat{T}_j(m, n) := L_j(g(T(m, n) | b^{(7)})) \quad j = 1, 2, 3. \quad (5.79)$$

We define

$$B'_8 := b^{(7)} + \left(B(n) \cup \left[\bigcup_{j=1,2,3} \hat{T}_j(m, n) \right] \right),$$

and we call $K^{(6+j)}(m, n)$ the set of the points x in $b^{(7)} + \hat{T}_j(n)$ which are directly connected inside \mathbb{G} to a seed contained in $b^{(7)} + \hat{T}_j(m, n)$.

Definition 5.13.2. We define the sets E_8, F_8 and C_9 as

$$\begin{aligned} E_8 &:= E[C_8, b^{(7)} + B(n), B'_8, 1], \\ F_8 &:= F[C_8, b^{(7)} + B(n), B'_8, 1], \\ C_9 &:= C_8 \cup E_8 \cup F_8. \end{aligned}$$

Moreover, we call S_9 the success event that C_9 contains at least one vertex inside $K^{(6+j)}$ for all $j = 1, 2, 3$.

If for $j = 1, 2, 3$, we define the event

$$F_j := \{C_9 \text{ contains at least one vertex inside } K^{(6+j)}\},$$

then we have that that $S_9 = \bigcap_{j=1,2,3} F_j$. Hence

$$\begin{aligned} \mathbb{P}(S_9 | S_1, S_2, \dots, S_8) &= 1 - \mathbb{P}\left(\bigcup_{j=1,2,3} F_j^c | S_1, S_2, \dots, S_8\right) \\ &\geq 1 - \sum_{j=1,2,3} \mathbb{P}(F_j^c | S_1, S_2, \dots, S_8). \end{aligned} \quad (5.80)$$

We claim that for any $j = 1, 2, 3$

$$\mathbb{P}(F_j | S_1, S_2, \dots, S_{2d+4}) \geq 1 - \varepsilon', \quad (5.81)$$

thus implying that

$$\mathbb{P}(S_9 | S_1, S_2, \dots, S_8) \geq 1 - 3\varepsilon'. \quad (5.82)$$

The proof of the above claim uses the arguments adopted in the proof of Lemma 5.9.3 and Lemma 5.10.3. Recall (5.71), (5.72), (5.73). To prove (5.81) we lower bound the conditional probability $\mathbb{P}(F_j | H_8)$ when $\mathbb{P}(H_8) > 0$. To this aim we apply Lemma 5.6.1 with $R := R_8$, $\Lambda(x) := \Lambda_8(x)$ and with $B(n)$, $T(n)$ and $T(m, n)$ replaced by $B(\tilde{b}_7, n)$, $\tilde{b}_7 + \hat{T}_j(n)$ and $\hat{T}_j(m, n)$ respectively, where $\hat{T}_j(n) := L_j(g(T(m, n) | b^{(7)}))$. The validity of (5.42) with $k_* := 1$ is assured by Lemma 5.13.1–(i).

Observe now that if also S_9 occurs, then the box $4Ne_1 + B(N)$ is linked-up with the boxes $\{Nv + B(N) | v = \pm e_1, \pm e_2\}$. To conclude the occupation of the box $4Ne_1 + B(N)$, we have to link-up the above box $Nv + B(N)$ with $2Nv + B(N)$. Observe that this operation, for $v = -e_1$, has already been done when we have constructed C_7 from C_6 and C_8 from C_7 . In the present setting, suppose that the event $\bigcap_{k=1}^9 S_k$ occurs. Since S_9 occurs, the cluster C_9 contains at least one seed in

$C_9 \cap (b^{(7)} + \hat{T}_j(m, n))$ for any $j \in 1, 2, 3$. We define $b^{(7+j)}$ as the minimal point $z \in \varepsilon\mathbb{Z}^d$ such that $B(z, m)$ is such a seed. Let us define

$$\begin{aligned} \hat{T}_1^*(n) &:= g(T(n) | b^{(8)}) & \hat{T}_1(m, n) &:= g(T(m, n) | b^{(8)}) \\ \hat{T}_2^*(n) &:= g'(\hat{T}_2(n) | b^{(9)}) & \hat{T}_2(m, n) &:= g'(\hat{T}_2(m, n) | b^{(9)}) \\ \hat{T}_3^*(n) &:= g'(\hat{T}_3(n) | b^{(10)}) & \hat{T}_3(m, n) &:= g'(\hat{T}_3(m, n) | b^{(10)}) \end{aligned}$$

where $g'(x | a) = (-\text{sgn}(a_1)x_1, x_2, -\text{sgn}(a_3)x_3, \dots, -\text{sgn}(a_d)x_d)$. moreover we define $B'_{6+j} := b^{(7+j)} + (B(n) \cup \hat{T}_j^*(m, n))$ and $K^{(7+j)}(m, n)$ as the set of the points x in $b^{(7+j)} + \hat{T}_j^*(n)$ which are directly connected inside \mathbb{G} to a seed contained in $b^{(7+j)} + \hat{T}_j^*(m, n)$.

Definition 5.13.3. For $j = 1, 2, 3$ we define the sets E_{9+j}, F_{9+j} and C_{9+j} as

$$\begin{aligned} E_{8+j} &:= E[C_{8+j}, b^{(7+j)} + B(n), B'_{8+j}, 1 + j], \\ F_{8+j} &:= F[C_{8+j}, b^{(7+j)} + B(n), B'_{8+j}, 1 + j], \\ C_{9+j} &:= C_{8+j} \cup E_{8+j} \cup F_{8+j}. \end{aligned}$$

Moreover, we call S_{9+j} the success-event that C_{9+j} contains at least one vertex inside $K^{(7+j)}(m, n)$.

We claim that

$$\mathbb{P}(S_{9+j} | S_1, S_2, \dots, S_{8+j}) \geq 1 - \varepsilon' \quad \forall j = 1, 2, 3. \quad (5.83)$$

To get (5.83), again, one has to apply Lemma 5.6.1 with $R := R_{8+j}$, $\Lambda(x) := \Lambda_{8+j}(x)$ and with $B(n), T(n)$ and $T(m, n)$ replaced respectively by $B(\tilde{b}_{7+j}, n), \tilde{b}_{7+j} + \hat{T}_j^*(n)$ and $\tilde{b}_{7+j} + \hat{T}_j^*(m, n)$. Note that condition (5.42) is satisfied with $k_* := 1 + j$ due to Lemma 5.13.1–(i).

Definition 5.13.4. We say that the box $4Ne_1 + B(N)$ is occupied and linked to the box $B(N)$ if the event $S_7 \cap \dots \cap S_{12}$ occurs.

So, by (5.76), (5.78), (5.82), (5.83) and Bernoulli's inequality, we get

$$\begin{aligned} \mathbb{P}(4Ne_1 + B(N) \text{ is occupied and linked to } B(N) | B(N) \text{ is occupied}) \\ \geq (1 - \varepsilon')^5 (1 - 3\varepsilon') \geq 1 - 8\varepsilon'. \end{aligned} \quad (5.84)$$

Note that for the entire construction up to now we have used the random variables $\{T_z^{(j)}\}$ with $j = 1, 2, \dots, 6$. Due to the localization properties stated in Lemma 5.13.1 and the periodicity of the lattice $4N\mathbb{Z}^d$, for the future steps in the construction of the cluster in the renormalized lattice $4N\mathbb{Z}^d$ we do not need more fields. Indeed, if for example we want to connect the boxes $B(N)$ and $4Ne_2 + B(N)$, we can repeat the same procedure used to connect $B(N)$ and $4Ne_1 + B(N)$ using $\{T_z^{(j)}\}$ with $j = 1, 2, \dots, 6$, since the sets $4Ne_1 + B(N)$ and $4Ne_2 + B(N)$ are far enough away. In particular, in the general step, one has to modify (5.72) as

$$\begin{aligned} \Lambda_j(x) &:= \{k \in \{1, 2, \dots, 6\} : \exists k' \in k + 6\mathbb{Z} \text{ such that} \\ &1 \leq k' \leq j - 2, x \in B(\tilde{b}_{k'}, n + 1)\}, \quad \forall x \in R_j \cup \partial R_j. \end{aligned} \quad (5.85)$$

Finally we point out that the region of $\varepsilon\mathbb{Z}^d$ explored during the construction up to C_{12} is localized inside suitable corridors (cf. Figure 5.9):

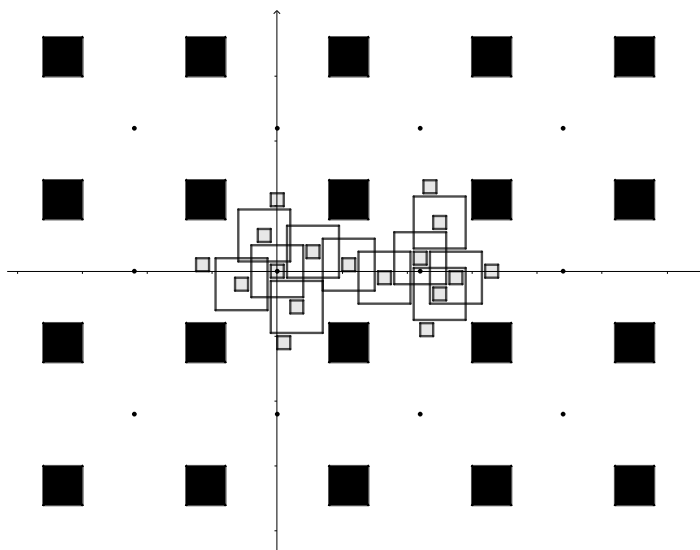

Figure 5.9. The black points in the figure are the points of the renormalized lattice $4N\mathbb{Z}^d$. The black boxes are made of points of $\varepsilon\mathbb{Z}^d$ that we do not visit when we construct the sets $\{C_i \cup \partial C_i\}_i$. In the picture are drawn the boxes obtained as translations of $B(n)$ (drawn in white) and $B(m)$ (drawn in grey) that have been considered to establish the occurrence of the events $\{B(N) \text{ is occupied}\}$ and $\{4Ne_1 + B(N) \text{ is occupied and linked to } B(N)\}$. Note that the drawn white and grey boxes do not intersect the black boxes. The corridors that appear in the picture between black boxes have half-width $2n - m$.

Proposition 5.13.5. For $y \in 4N\mathbb{Z}^d$, define

$$Z_y := y + \{x \in \varepsilon\mathbb{Z}^d \mid \min\{|x_1|, |x_2|\} \leq 2n - m, |x_j| \leq 2n - m \text{ for } j = 3, \dots, d\}.$$

Suppose that the event $S_1 \cap \dots \cap S_{12}$ occurs. The following inclusions hold

$$(a) \cup_{k=1}^{11} B'_k \subset Z_0 \cup Z_{4Ne_1},$$

$$(b) \cup_{k=1}^5 B'_k \subset B(2N + m),$$

$$(c) \cup_{k=7}^{11} B'_k \subset 4Ne_1 + B(2N + n),$$

$$(d) B'_6 \cup B'_7 \subset [2N - n, 4N + m] \times [-2n + m, 2n - m]^{d-1}.$$

The proof of the above fact is given in Section 5.16.

5.14 Extended construction by success-events

In the following we say that 0 is occupied if $B(N)$ is occupied and e_1 is occupied and linked to 0 if $B(4Ne_1, N)$ is occupied and linked to $B(N)$.

In the previous sections we have explained how to check if the origin is occupied and (in affirmative case) if e_1 is occupied and linked to the origin. These will be the two basic steps in the algorithmic construction presented in Section 5.15. There we will start with a point, which we take now equal to the origin, and we will iteratively

define an increasing set \mathbb{X} of occupied and linked points, by means of success-events, until the algorithm stops. In general when $\mathbb{X} \neq \emptyset$ we will provide in Section 5.15 a rule to decide if we have to stop the algorithm or not. If the algorithm is not stopped, the rule will also indicate how to choose points $v \notin \mathbb{X}$ and $w \in \mathbb{X}$ such that $\|v - w\|_1 = 1$. Roughly, the algorithm is structured as follows. First we check if the origin is occupied according to Definition 5.11.4. If it is not occupied, then we end the algorithm with output $\mathbb{X} := \emptyset$, otherwise we temporary set $\mathbb{X} := \{0\}$ and apply the above rule. Suppose the algorithm is not stopped by the rule. In this case, as $\mathbb{X} = \{0\}$, necessarily $w = 0$ and v is nearest neighbor to the origin. We therefore check if v is occupied and linked to the origin according to Definition 5.13.4 (with e_1 replaced by v). If this happens, then we update the value of \mathbb{X} by temporary setting $\mathbb{X} := \{0, v\}$, otherwise we do not update the set \mathbb{X} . At this point, we apply again the above rule and proceed as before continuing iteratively in this way. We stress that the rule will definitely stop the algorithm.

We point out that in order to decide if the origin is occupied or not we reveal only random variables associated to points in $B(2N + m)$ (cf. Fig. 5.8). If the origin is occupied, in order to decide if e.g. e_1 is occupied and linked to the origin, we reveal only random variables associated to points in $B(4Ne_1, 2N + n) \cup B(2Ne_1, 2N)$ (cf. Fig. 5.8). When extending the construction by the algorithm mentioned above and described in Section 5.15, since we explore uniformly bounded regions, by taking K large enough in Definition 5.3.4 we can iteratively apply Lemma 5.6.1 assuring condition (5.42) to be fulfilled simply by using some index $k_* \in \{1, 2, \dots, K\}$ not already used in the region under exploration.

We point out another relevant issue when adapting the steps described in the previous sections to the extended construction of Section 5.15. In order to check if e_1 is occupied and linked to the origin we have considered also the success-events S_{10}, S_{11}, S_{12} . These success-events are thought in order to assure the presence of seeds localized in $b^{(i)} + T_i(m, n)$ for $i = 9, 10, 11$, which would allow to continue the construction in direction e_1, e_2 and $-e_2$, respectively. In the extended construction, when we need to check if a vertex v is occupied and linked to some vertex w , we remove the success-events associated to seeds which would direct the construction towards a box already explored. For example, suppose that 0 is occupied and e_1 is occupied and linked to 0. Suppose that the rule requires now to check if e_2 is occupied and linked to 0. We do this by success-events similar to the events S_3, \dots, S_{12} described in the previous sections, now in direction e_2 . Suppose now that the rule requires to check if $e_2 + e_1$ is occupied and link to e_2 . We do this by success-events similar to the events S_3, \dots, S_{11} described before. Note that the analogous of S_{12} has been removed since the region around $4Ne_1$ has already been explored.

In Section 5.15, after constructing the set \mathbb{X} , we construct iteratively other sets \mathbb{X}' by a similar procedure. In order to lower bound the conditional probability one can anyway apply Lemma 5.6.1. We also point out that in Section 5.15 we first check the occupation of the starting points of the \mathbb{X}' -type sets (the points analogous to the origin for \mathbb{X}) and afterwards proceed with the construction described above. The final result is the same.

At the end, conditioned to the previous construction, the probability that the first point in \mathbb{X}' is occupied is lower bounded by $1 - 8\varepsilon'$, and that a point v is occupied

and linked to a given point w of the built set \mathbb{X}' is lower bounded by $1 - 8\varepsilon'$.

5.15 Proof of Theorem 4 in Section 5.3

Having recovered results on the renormalized lattice similar to the ones in [10], the proof of Theorem 4 follows the main strategy developed in [15, Section 4] with suitable modifications and extensions.

Let $p_c(2)$ be the critical probability for the 2-dimensional site percolation. We take ε' small enough that $1 - 8\varepsilon' \geq 3/4 > p_c(2)$. We first show that it is enough to deal with 2-dimensional slices. To this aim recall that $\Delta_L = [-L - 2, L + 2] \times [-L, L]^{d-1}$. We introduce the set $V(a, r) := a + [-r, r]^{d-2}$, we denote by \mathbb{L} the set $4N\mathbb{Z}^{d-2}$ and, for each $z \in \mathbb{L}$, we consider the slice

$$\Delta(z) := ([-L - 2, L + 2] \times [-L, L] \times V(z, 4N)) \cap \varepsilon\mathbb{Z}^d.$$

Note that, when varying $z \in \mathbb{L}$, the above slices are disjoint and that Δ_L contains at least $\lfloor 2L/8N \rfloor^{d-2} \asymp c_0 L^{d-2}$ slices of the above form.

We denote by R_L the maximal number of vertex-disjoint LR crossings of Δ_L in \mathbb{G}_* which are included in the slice $\Delta(0)$. We claim that there exist positive constants c_1, c_2 such that, for L large enough, it holds

$$\mathbb{P}(R_L \geq c_1 L) \geq 1 - e^{-c_2 L}. \quad (5.86)$$

Let us first show that (5.86) implies Theorem 4. To this aim we assume (5.86). By translation invariance and independence (cf. Definition 5.3.4) the number of disjoint slices $\Delta(z) \subset \Delta_L$ including at least $c_1 L$ vertex-disjoint LR crossings of Δ_L for \mathbb{G}_* stochastically dominates a binomial random variable Y with parameters $n \asymp c_0 L^{d-2}$ and $p := 1 - e^{-c_2 L}$. Setting $\delta := e^{-c_2 L}$ we get

$$\begin{aligned} \mathbb{P}(R_L < n/2) &\leq P(Y < n/2) = P(\delta^Y > \delta^{n/2}) \leq \delta^{-n/2} E[\delta^Y] = \delta^{-n/2} [\delta p + 1 - p]^n \\ &= \delta^{-n/2} [\delta - \delta^2 + \delta]^n \leq \delta^{-n/2} [2\delta]^n = 2^{c_0(1+o(1))L^{d-2}} e^{-c_0 c_2(1+o(1))L^{d-1}/2}, \end{aligned}$$

thus implying (5.14) in Theorem 4.

It remains now to prove (5.86). In order to have a notation close to the one in [15, Section 4], we consider the box

$$\Lambda := ([0, M + 1] \times [0, M - 1]) \cap \mathbb{Z}^2,$$

where M will be linearly related to L as explained at the end.

Let (x_1, x_2, \dots, x_n) be a string of points in Λ , such that the set $\{x_1, x_2, \dots, x_n\}$ is connected when thinking to Λ as a graph with edges $\{x_i, x_j\}$ with $|x_i - x_j| = 1$. We introduce a total order on $\Delta\{x_1, \dots, x_n\}$ (in general, given $A \subset \mathbb{Z}^2$, $\Delta A := \{y \in \mathbb{Z}^2 \setminus A : |x - y| = 1 \text{ for some } x \in A\}$). We have to modify the definition in [15, Section 4] which is restricted there to the case that (x_1, x_2, \dots, x_n) is a path in \mathbb{Z}^2 . For later use, it is more convenient to describe the ordering from the largest to the smallest element. We denote by Ψ the anticlockwise rotation of $\pi/2$ around the origin in \mathbb{R}^2 (in particular, $\Psi(e_1) = e_2$ and $\Psi(e_2) = -e_1$). We first introduce an

5. Left-right crossings in the Miller-Abrahams random resistor network

order \prec_k on the sites in \mathbb{Z}^2 neighboring x_k as follows. Putting $x_0 := x_1 - e_1$, for $k = 1, 2, \dots, n$ we set

$$x_k + \Psi(v) \succ_k x_k + \Psi^2(v) \succ_k x_k + \Psi^3(v) \succ_k x_k + \Psi^4(v) = x_{a(k)},$$

where $v := x_{a(k)} - x_k$ and $a(k) := \max\{j : 0 \leq j \leq n \text{ and } |x_k - x_j| = 1\}$. The order on $\Delta\{x_1, \dots, x_n\}$ is obtained as follows. The largest elements are the sites of $\Delta\{x_1, \dots, x_n\}$ neighboring x_n (if any), ordered according to \succ_n . The next elements, in decreasing order, are the sites $\Delta\{x_1, \dots, x_n\}$ neighboring x_{n-1} but not x_n (if any), ordered according to \succ_{n-1} . As so on, in the sense that in the generic step one has to consider the elements of $\Delta\{x_1, \dots, x_n\}$ neighboring x_k but not x_{k+1}, \dots, x_n (if any), ordered according to \succ_k .

Let F_0 be the event

$$F_0 := \{B(4Nx, m) \text{ is a seed } \forall x \in \Lambda \text{ with } x = (0, s) \text{ for some } s\}.$$

We now define a random field $\zeta = (\zeta(x) : x \in \Lambda)$ with $\zeta(x) \in \{0, 1\}$ on the probability space (Θ, \mathbb{Q}) where $\mathbb{Q} := \mathbb{P}(\cdot | F_0)$ (cf. Definition 5.3.4).

To define the field ζ , we have to build the sets $C_j^s = (E_j^s, F_j^s)$, with $s \in \{0, 1, \dots, M-1\}$ and $j = 1, 2, \dots, M^2$, and the sites x_j^s such that $E_j^s \cup F_j^s = \{x_1^s, x_2^s, \dots, x_j^s\}$. The construction will fulfill the following properties: E_j^s will be a connected subset of Λ ; (E_{j+1}^s, F_{j+1}^s) will be obtained from (E_j^s, F_j^s) by adding exactly a point (called x_{j+1}^s) either to E_j^s or to F_j^s ; $\zeta \equiv 1$ on E_j^s and $\zeta \equiv 0$ on F_j^s .

In what follows, the index s will vary in $\{0, 1, \dots, M-1\}$. We also set $x_1^s := (0, s)$. We build the sets $C_1^0, C_1^1, \dots, C_1^{M-1}$ as follows. We say that x_1^s is occupied if the analogous of Definition 5.11.4, with removed success-events S_3, S_4, S_5 , is fulfilled. If the point x_1^s is occupied, then we set

$$\zeta(x_1^s) := 1 \text{ and } C_1^s := (E_1^s, F_1^s) := (\{x_1^s\}, \emptyset), \quad (5.87)$$

otherwise we set

$$\zeta(x_1^s) := 0 \text{ and } C_1^s := (E_1^s, F_1^s) := (\emptyset, \{x_1^s\}). \quad (5.88)$$

We then define iteratively

$$C_2^0, C_3^0, \dots, C_{M^2}^0, C_2^1, C_3^1, \dots, C_{M^2}^1, \dots, C_2^{M-1}, C_3^{M-1}, \dots, C_{M^2}^{M-1} \quad (5.89)$$

as follows. If $E_1^s = \emptyset$, then we set $C_j^s := C_1^s$ for all $j : 2 \leq j \leq M^2$. We restrict now to the case $E_1^s \neq \emptyset$. Suppose we have defined all the sets preceding C_{j+1}^s in the above string (5.89) and we want to define C_{j+1}^s . We call W_j^s the points of Λ involved in the construction up to this moment, i.e.

$$W_j^s = \{x_1^k : 0 \leq k \leq M-1\} \cup \{x_r^{s'} : 0 \leq s' < s, 1 < r \leq M^2\} \cup \{x_r^s : 1 < r \leq j\}.$$

As already mentioned, it must be $E_0^s \subset E_1^s \subset \dots \subset E_j^s$ and at each inclusion either the two sets are equal or the second one is obtained from the first one by adding exactly a point. We then write \bar{E}_j^s for the non-empty string obtained by ordering the points of E_j^s according to the chronological order with which they have been added. Equivalently, x_a^s precedes x_b^s in \bar{E}_j^s if $a < b$. Hence the total order in $\Delta\bar{E}_j^s$ is

5.15 Proof of Theorem 4 in Section 5.3

well defined. We call \mathcal{P}_j^s the following property: E_j^s is disjoint from the right vertical face of Λ , i.e. $E_j^s \cap (\{M+1\} \times \{0, 1, \dots, M-1\}) = \emptyset$, and $(\Lambda \cap \Delta \bar{E}_j^s) \setminus W_j^s \neq \emptyset$. If property \mathcal{P}_j^s is satisfied, then we denote by x_{j+1}^s the last element of $(\Lambda \cap \Delta \bar{E}_j^s) \setminus W_j^s$. We define k as the largest integer k such that $x_k^s \in E_j^s$ and $|x_{j+1}^s - x_k^s| = 1$. If x_{j+1}^s is occupied and linked to x_k^s (cf. Definition 5.13.4), then we set

$$\zeta(x_{j+1}^s) := 1 \text{ and } C_{j+1}^s := \left(E_j^s \cup \{x_{j+1}^s\}, F_j^s \right), \quad (5.90)$$

otherwise we set

$$\zeta(x_{j+1}^s) := 0 \text{ and } C_{j+1}^s := \left(E_j^s, F_j^s \cup \{x_{j+1}^s\} \right). \quad (5.91)$$

On the other hand, if property \mathcal{P}_j^s is not verified, then we set $x_{j+1}^s := x_j^s$ (hence $\zeta(x_{j+1}^s)$ has already been defined) and $C_{j+1}^s := C_j^s$.

It is possible that the set $\cup_{s=0}^{M-1} \cup_{j=1}^{M^2} (E_j^s \cup F_j^s)$ does not fill all Λ . In this case we set $\zeta \equiv 0$ on the remaining points. This completes the definition of the random field ζ .

Above we have constructed the sets C_j^s in the following order: $C_1^0, C_1^1, \dots, C_1^{M-1}, C_2^0, C_3^0, \dots, C_{M^2}^0, C_2^1, C_3^1, \dots, C_{M^2}^1, \dots, C_2^{M-1}, C_3^{M-1}, \dots, C_{M^2}^{M-1}$. By Proposition 5.11.5 and (5.84), at every step the probability to add a point to a set of the form E_*^s , conditioned to the construction performed before such a step, is lower bounded by $1 - 8\varepsilon' \geq 3/4$.

Call N_M the maximal number of vertex-disjoint LR crossings of the box Λ for ζ (here crossings are the standard ones for percolation on \mathbb{Z}^d [9]). Note that N_M also equals the number of indexes $s \in \{0, 1, \dots, M-1\}$ such that $E_{M^2}^s$ intersect the right vertical face of Λ . By establishing a stochastic domination on a 2-dimensional site percolation in the same spirit of [10, Lemma 1] (cf. [15, Lemma 4.1]) and using the above lower bound on the conditional probability to add a point to a set of the form E_*^s , one obtains that N_M stochastically dominates the corresponding number in a site percolation of parameter $p = 3/4 > p_c(2)$. Hence there exist $c_3, c_4 > 0$ such that $\mathbb{Q}(N_M \geq c_3 M) \geq 1 - e^{-c_4 M}$ for M large enough [9].

In the rest we derive (5.86) from the above bound on $\mathbb{Q}(N_M \geq c_3 M)$. Due to the translation invariance of \mathbb{P} , it is enough to prove (5.86) with $\Delta(0)$ replaced by $\Delta(0)' := ([m+1, 2L+5+m] \times [0, 2L] \times [-4N, 4N]^{d-2}) \cap \varepsilon \mathbb{Z}^d$. We take M as the minimal integer such that $(M+1)4N > 2L+5+m+N$. Without loss of generality, when referring to the LR crossings of the box Λ for ζ we restrict to crossings such that only the first and the last points intersect the vertical faces of Λ (which would not change the random number N_M). We fix a set Γ' of vertex-disjoint LR crossings of Λ for ζ with cardinality N_M . Then we define Γ as the set of paths (x_1, x_2, \dots, x_k) in Γ' such that x_i has second coordinate in $[1, M-2]$ for each i . Note that, since Λ is bidimensional, $|\Gamma| \geq |\Gamma'| - 2$. Given $x \in \mathbb{Z}^2$ we set $\bar{x} := (x, 0, 0, \dots, 0) \in \mathbb{Z}^d$.

Take a LR crossing (x_1, x_2, \dots, x_k) in Γ . By the discussion in the previous sections, we get that there is a path γ in \mathbb{G}_* from $B(4N\bar{x}_1, m)$ to $B(4N\bar{x}_k, N)$ without self-intersections. Moreover, this path is included in the region \mathcal{R} obtained as union of the boxes $B(4N\bar{x}_i, 3N)$ with $i = 1, \dots, k$ (see Fig. 5.8). We point out that the second coordinate of any point in $B(4N\bar{x}_i, 3N)$ is in $[4N-3N, 4N(M-2)+3N] \subset [0, 2L]$ due to the definition of Γ and since $4NM \leq 2L+5+m+N$ by the minimality of M .

In addition, the box $B(4N\bar{x}_1, m)$ lies in the halfspace $\{(z_1, \dots, z_d) \in \varepsilon\mathbb{Z}^d : z_1 \leq m\}$, while the box $B(4N\bar{x}_k, N)$ lies in the halfspace $\{(z_1, \dots, z_d) \in \varepsilon\mathbb{Z}^d : z_1 > 2L + 5 + m\}$ (by our choice of M). As a consequence we can extract from the above path γ a new path $\tilde{\gamma}$ for \mathbb{G}_* lying in $\mathcal{R} \cap \{(z_1, \dots, z_d) \in \varepsilon\mathbb{Z}^d : m \leq z_1 \leq 2L + 5 + m, 0 \leq z_2 \leq 2L\} \subset \Delta(0)'$. At cost to further refine $\tilde{\gamma}$ we have that $\tilde{\gamma}$ is a LR crossing of $\Delta(0)'$. Moreover, due to the dimension 2, there is an integer ℓ such that every path $\tilde{\gamma}$ can share some vertex with at most ℓ paths $\tilde{\gamma}'$ with $\gamma' \in \Gamma$. Since $M \geq c_5L$, by the above observations we have proved that the event $\{N_M \geq c_3M\}$ implies the event F that $\Delta(0)'$ has at least c_6L vertex-disjoint LR crossings for \mathbb{G}_* . Hence, by our bound on $\mathbb{Q}(N_M \geq c_3M)$ and since $M \leq c_7L$, we get that $\mathbb{Q}(F) \geq 1 - e^{-c_8L}$. Since edges in \mathbb{G}_* have length bounded by 1, the event F does not depend on the vertexes of \mathbb{G}_* in $\cup_{s=0}^{M-1} B(4N\bar{x}_1^s, m)$, neither on the edges exiting from the above region. In particular, F and F_0 are independent, thus implying that $\mathbb{P}(F) = \mathbb{P}(F|F_0) = \mathbb{Q}(F) \geq 1 - e^{-c_8L}$, and in particular (5.86) is verified.

5.16 Proof of Proposition 5.13.5

Proposition 5.13.5 is a direct consequence of all the following lemmas.

Lemma 5.16.1. *If $x \in (\cup_{k=1}^5 B'_k)$, then $x \in Z_0$. Moreover $\cup_{k=1}^5 B'_k \subset B(2N + m)$.*

Proof. Note that for $j = 2, 4$ it holds

$$|b_1^{(j-1)}| = N \quad \text{and} \quad |b_i^{(j-1)}| \in [m, n - m] \text{ for } i = 2, 3, \dots, d,$$

while for $j = 3, 5$ it holds

$$|b_2^{(j-1)}| = N \quad \text{and} \quad |b_i^{(j-1)}| \in [m, n - m] \text{ for } i = 1, 3, 4, \dots, d.$$

Let (i, j) be an element of $(\{1, 3, 4, \dots, d\} \times \{3, 5\}) \cup (\{2, 3, 4, \dots, d\} \times \{2, 4\})$. Consider $x \in B'_j$. We have $|x_i - b_i^{(j-1)}| \leq n$ and, since $|b_i^{(j-1)}| \in [m, n - m]$, we get

$$|x_i| \leq |x_i - b_i^{(j-1)}| + |b_i^{(j-1)}| \leq n + n - m = 2n - m.$$

Moreover, since points in $B(n)$ have uniform norm not bigger than $n \leq 2n - m$, we get that

$$\cup_{k=2}^5 B'_k \cup B(n) = \cup_{k=1}^5 B'_k \subset Z_0.$$

Using the above inclusion and noting that $2n - m \leq 2N + m$, the second part of the lemma is trivial and can be easily checked looking at Figure 5.8 \square

Lemma 5.16.2. *If $x \in B'_6 \cup B'_7$, then $|x_i| \leq 2n - m$ for $i = 2, 3, \dots, d$ and hence $x \in Z_0 \cap Z_{4Ne_1}$. Moreover $B'_6 \subset [2N - n, 3N + m] \times [-2n + m, 2n - m]^{d-1}$ and $B'_7 \subset [3N - n, 4N + m] \times [-2n + m, 2n - m]^{d-1}$.*

Proof. Recall that $b_1^{(1)} = N$ and $b_i^{(1)} \in [m, n - m]$ for $i = 2, 3, \dots, d$.

We first localize $b^{(5)}$ and $b^{(6)}$. Note that

$$b_1^{(5)} = b_1^{(1)} + N = 2N, \quad b_1^{(6)} = b_1^{(5)} + N = 3N.$$

5.16 Proof of Proposition 5.13.5

Moreover by construction for $i = 2, \dots, d$

$$b_i^{(5)} \in [b_i^{(1)} - n + m, b_i^{(1)} - m] \subset [-n + m, n - m], \quad (5.92)$$

and hence

- if $b_i^{(5)} > 0$ (that is, by (5.92), $b_i^{(5)} \in [0, n - m]$), then

$$b_i^{(6)} \in [b_i^{(5)} - n + m, b_i^{(5)} - m] \subset [-n + m, n - 2m],$$

- if $b_i^{(5)} \leq 0$ (that is, by (5.92), $b_i^{(5)} \in [-n + m, 0]$), then

$$b_i^{(6)} \in [b_i^{(5)} + m, b_i^{(5)} + n - m] \subset [-n + 2m, n - m].$$

So

$$b_i^{(6)} \in [-n + m, n - m]. \quad (5.93)$$

Let $i \in \{2, 3, \dots, d\}$ and $j \in \{6, 7\}$. If $x \in B'_j$, by (5.92) for $j = 6$ and (5.93) for $j = 7$, we have $x_i \in [-n + b_i^{(j-1)}, b_i^{(j-1)} + n] \subset [-2n + m, 2n - m]$.

So we have the first part of the lemma. Since we have just proved that $B'_6 \cup B'_7 \subset \{x \in \varepsilon\mathbb{Z}^d : |x_i| \leq 2n - m \text{ for } i = 2, \dots, d\}$, the second part of the lemma is trivial when looking at Figure 5.8. \square

Lemma 5.16.3. *If $x \in \cup_{k=8}^{11} B'_k$, then $x \in Z_{4Ne_1}$. Moreover $\cup_{k=7}^{11} B'_k \subset 4Ne_1 + B(2N + n)$.*

Proof. First we localize $b^{(7)}, \dots, b^{(10)}$. By construction $b_1^{(1)} = N$, $b_1^{(5)} = b_1^{(1)} + N = 2N$ and $b_1^{(j)} = b_1^{(j-1)} + N$ for $j = 6, 7$. So $b_1^{(7)} = 4N$.

Moreover for $i = 2, 3, \dots, d$

- if $b_i^{(6)} > 0$ (that is, by (5.93), $b_i^{(6)} \in [0, n - m]$), then

$$b_i^{(7)} \in [b_i^{(6)} - n + m, b_i^{(6)} - m] \subset [-n + m, n - 2m],$$

- if $b_i^{(6)} \leq 0$ (that is, by (5.93), $b_i^{(6)} \in [-n + m, 0]$), then

$$b_i^{(7)} \in [b_i^{(6)} + m, b_i^{(6)} + n - m] \subset [-n + 2m, n - m].$$

So

$$b_i^{(7)} \in [-n + m, n - m]. \quad (5.94)$$

Moreover for $i = 2, 3, 4, \dots, d$ and $j \in \{9, 10, 11\}$ we have

- if $b_i^{(7)} > 0$ (that is, by (5.94), $b_i^{(7)} \in [0, n - m]$), then

$$b_i^{(j-1)} \in [b_i^{(7)} - n + m, b_i^{(7)} - m] \subset [-n + m, n - 2m],$$

- if $b_i^{(7)} \leq 0$ (that is, by (5.94), $b_i^{(7)} \in [-n + m, 0]$), then

$$b_i^{(j-1)} \in [b_i^{(7)} + m, b_i^{(7)} + n - m] \subset [-n + 2m, n - m].$$

So for $i = 2, 3, 4, \dots, d$ and $j \in \{9, 10, 11\}$

$$b_i^{(j-1)} \in [-n + m, n - m]. \quad (5.95)$$

Applying (5.95), given $x \in B'_j$ with $j \in \{9, 10, 11\}$, it is possible to localize x_i for $i \in \{3, 4, \dots, d\}$. Indeed

$$x_i \in [b_i^{(j-1)} - n, b_i^{(j-1)} + n] \subset [-2n + m, 2n - m]. \quad (5.96)$$

We prove now the following items:

- (i) if $x \in B'_j$ with $j \in \{10, 11\}$, it holds $|x_1| \leq 4N + 2n - m$
- (ii) if $x \in B'_9$, it holds $|x_2| \leq 2n - m$.

Indeed by proving items (i) and (ii), we conclude the proof of the first part of the lemma.

Let us start from item (i). Suppose that $x \in B'_j$ with $j \in \{10, 11\}$ and observe that $|x_1 - b_1^{(j-1)}| \leq n$. Moreover by construction $|b_1^{(j-1)} - b_1^{(7)}| \leq n - m$. Hence

$$|x_1| \leq |x_1 - b_1^{(j-1)}| + |b_1^{(j-1)} - b_1^{(7)}| + |b_1^{(7)}| \leq n + n - m + 4N = 2n - m + 4N,$$

where we have used the identity $b_1^{(7)} = 4N$. So by the above inequality and (5.96) we have $B'_{10} \cup B'_{11} \subset Z_{4Ne_1}$.

Consider now item (ii). Suppose now that $x \in B'_9$ and observe that $|x_2 - b_2^{(8)}| \leq n$ and hence by (5.95) we get

$$|x_2| \leq |x_2 - b_2^{(8)}| + |b_2^{(8)}| \leq n + n - m = 2n - m.$$

So by the above inequality and (5.96) we have $B'_9 \subset Z_{4Ne_1}$.

Moreover note that all the points $x \in b^{(7)} + B(n)$ satisfy $|x_1 - 4N| \leq n$ and hence

$$\cup_{k=9}^{11} B'_k \cup (b^{(7)} + B(n)) = \cup_{k=8}^{11} B'_k \subset Z_{4Ne_1}.$$

Note that $\cup_{k=7}^{11} B'_k \subset b^{(7)} + B(2N + m)$ (this fact can be easily checked using the inclusion that we have just proved, Lemma 5.16.2 and Figure 5.8). By (5.94), the above inequality implies the second part of the lemma. \square

Bibliography

- [1] V. Ambegoakar, B.I. Halperin, J.S. Langer. *Hopping conductivity in disordered systems*. Phys, Rev B **4**, 2612-2620 (1971).
- [2] A. Faggionato. *Mott's law for the effective conductance of the Miller–Abrahams random resistor network*. Preprint (2017).
- [3] A. Faggionato. *Stochastic homogenization in amorphous media and applications to exclusion processes*. Preprint, arXiv:1903.07311 (2019).

Bibliography

- [4] A. Faggionato. *Miller–Abrahams random resistor network, Mott random walk and 2-scale homogenization*. Forthcoming.
- [5] A. Faggionato. *Mott’s law for Miller–Abrahams random resistor network and for Mott random walk*. In preparation.
- [6] A. Faggionato, P. Mathieu. *Mott law as upper bound for a random walk in a random environment*. *Comm. Math. Phys.* **281**, 263–286 (2008).
- [7] A. Faggionato, H.A. Mimun. *Connection probabilities in Poisson random graphs with uniformly bounded edges*. *ALEA* **16** 463–486 (2019).
- [8] A. Faggionato, H. Schulz–Baldes, D. Spehner. *Mott law as lower bound for a random walk in a random environment*. *Comm. Math. Phys.*, **263**, 21–64 (2006).
- [9] G.R. Grimmett. *Percolation*. Second edition. Die Grundlehren der mathematischen Wissenschaften **321**. Springer Verlag, Berlin, 1999.
- [10] G.R. Grimmett, J.M. Marstrand. *The supercritical phase transition of percolation is well behaved*. *Proceedings: Mathematical and Physical Sciences*, Vol. 430, No. 1879, pp. 439–457 (1990).
- [11] H. Kesten. *Percolation theory for mathematicians*. Birkhäuser, 1982.
- [12] R. Meester, R. Roy. *Continuum percolation*. Cambridge Tracts in Mathematics **119**. First edition, Cambridge University Press, Cambridge, 1996.
- [13] A. Miller, E. Abrahams. *Impurity Conduction at Low Concentrations*. *Phys. Rev.* **120**, 745–755 (1960).
- [14] M. Pollak, M. Ortuño, A. Frydman. *The electron glass*. First edition, Cambridge University Press, United Kingdom, 2013.
- [15] H. Tanemura. *Behavior of the Supercritical Phase of a Continuum Percolation Model on \mathbb{R}^d* . *J. Appl. Prob.* **30**, 382–396 (1993).

