

Breast Cancer Epidemic Model and Optimal Control

Martina Brunetti, Paolo Di Giamberardino^a, Daniela Iacoviello^b and Marialourdes Ingresso

Department of Computer Control and Management Engineering Antonio Ruberi, Sapienza University of Rome, Rome, Italy

Keywords: Modelling, Breast Cancer, Containment Strategies, Optimal Control.

Abstract: The breast cancer represents one of the most frequent disease diagnosed worldwide; with the modern improvements in medicine and technology a fast detection of tumor could allow a total recovery. In this paper, it is proposed a compartmental epidemiological model in which the female population is partitioned depending on the condition with respect to the tumor diagnosis. The model is identified referring to the population of a region of Italy, using real data; increasing levels of control are introduced, from noninvasive prevention to combination of surgery and chemotherapy. In the framework of optimal control, aiming at reducing the number of severe cases and of women dead by tumor, a suitable combination of control effort is determined, considering constraints in the containment measures. Numerical results stress the importance of prevention that at the very beginning increases the number of discovered positive diagnosis, and, successively, significantly contains the fatal consequences of breast cancer on the population by reducing the late diagnosis.

1 INTRODUCTION

Breast cancer is the most common type of cancer diagnosed worldwide; accounting for nearly 12% of all tumor cases, it is the type of cancer that causes the highest number of deaths among the female population, (WHO, 2023). It can be invasive or non-invasive, (Alkabban and Ferguson, 2022) and can take various forms depending on the particular type of breast cells that are harmed; breast cancers are typically ductal or lobular epithelial tumors, (Choi, 2022). Carcinomas, which begin in the epithelial cells that line the body's organs and tissues, are the most common type of breast cancer, while adenocarcinoma, a more specific type of carcinoma that begins in cells in the ducts or lobules, is the typical carcinoma that develops in the breast. The most frequent forms of breast cancer are:

- Ductal carcinoma in situ (DCIS): it is a non-invasive or pre-invasive breast cancer also known as intraductal carcinoma or *stage 0* breast cancer.
- Invasive (infiltrating) ductal carcinoma (IDC): it begins in the breast's milk duct's cell lining. From there, the cancer spreads into the adjacent breast tissues after penetrating the duct's wall. It might be able to metastasize to other parts of the body

through the lymph system and bloodstream.

- Invasive lobular carcinoma (ILC): it starts in the lobules and may spread to other bodily regions. On physical exam and imaging, ILC could be harder than IDC to detect.

There are other forms of breast cancer less frequent than those previously mentioned which may have a better prognosis than the more prevalent IDC, (American Cancer Society, 2023). These include: Adenoid cystic (or adenocystic) carcinoma, Low-grade adenosquamous carcinoma (this is a type of metaplastic carcinoma), Medullary carcinoma, Mucinous (or colloid) carcinoma, Papillary carcinoma and Tubular carcinoma. The American Joint Committee on Cancer (AJCC) has developed and updated the Tumor-Node-Metastasis (TNM) staging system for breast cancer. The staging is determined by the size and location of the tumor, the spread to lymph nodes or other parts of the body, the grade of the tumor and the presence of biomarkers, (City of Hope, 2023). There are five general stages under the TNM system for the breast cancer:

- Stage 0: it is known as "carcinoma in situ"; cancer cells are present but they haven't spread yet.
- Stage 1: the tumor is very small and may or may not have migrated to a neighboring lymph node. A cancer that has spread into the surrounding area is referred to as *invasive breast cancer*. In particular:

^a  <https://orcid.org/0000-0002-9113-8608>

^b  <https://orcid.org/0000-0003-3506-1455>

- Stage 1A: the tumor is smaller than 0.2 mm and has not spread to the lymph nodes.
- Stage 1B: Cancer between 0.2 mm and 2 mm is found in the lymph nodes.
- Stage 2: compared to stage 1, the tumor is larger and might have migrated to a few nearby lymph nodes. In particular:
 - Stage 2A: Though it can't be detected, the tumor has spread from one to three lymph nodes (but has not spread to other parts of the body). The tumor can be 20 mm or smaller (less than 20 mm it cannot be identified) and can spread to one to three lymph nodes, or the tumor is between 20 mm and 50 mm and has not spread to lymph nodes.
 - Stage 2B: The tumor is between 20 mm and 50 mm and has spread to one to three lymph nodes, or the tumor is larger than 50 mm but has not spread to any lymph nodes.
- Stage 3: the tumor is larger than at stage 2 and/or has spread to several lymph nodes and/or to tissue around the breast or breast bone. In particular:
 - Stage 3A: The tumor has spread from four to nine lymph nodes or to mammary lymph nodes, but not to other parts of the body; or the tumor is larger than 50 mm and spread to one to three lymph nodes.
 - Stage 3B: The tumor has spread to the chest area or caused the breast to swell, or it is inflammatory breast cancer. It may have spread to up to nine lymph nodes but has not spread to other parts of the body.
 - Stage 3C: This refers to any tumor that has spread to 10 or more lymph nodes, including those under the collarbone, but has not spread to other parts of the body.
- Stage 4: the cancer has metastasized, or mobilized, and spread to distant parts of the body, typically bones, lungs or liver. This is an advanced stage of cancer, called *metastatic breast cancer*.

It is possible to have recurrence breast cancer within the first two or three years after treatment, but, in some cases, it may recur also many years later, (City of Hope, 2023).

Screening is essential since early diagnosis can change the course of the disease by avoiding reaching the metastatic form; without any form of prevention, there is a risk of tumor growth and of its spread through metastases, affecting the success of the therapy and decreasing the probability of survival. Diagnostic tests (e.g. mammography, ultrasonography, magnetic resonance imaging, breast self-examination,

as well as modern and more precise imaging methods) help the early detection of tumors or lesions predisposing to tumors, (Kolak et al., 2017).

The problem of the containment of breast cancer has been faced also studying the patient's molecular profile, to predict the drug response, as in (Huang et al., 2021). A compartmental modeling approach is proposed in (Tang et al., 2022), where adverse reaction on the patient heart (cardiotoxicity) is studied in the framework of fractional calculus.

The aim of this paper is to carry out an *epidemiological study* of the spread of breast cancer, proposing a compartmental model able to represent, in a simplified way, the population partitioned with respect to the individuals' conditions regarding the breast cancer. Male breast cancer is rare and accounts for about 1% of cancers occurring in men and about 1% of all breast cancers worldwide, so the target population is the female population, (Fox et al., 2022). In particular, five compartments are introduced:

- Healthy population.
- Population at stage 0, 1 and 2.
- Population at stage 3 and 4.
- Population of dead subjects from causes different from breast cancer.
- Population of dead individuals because of breast cancer.

The population division is inspired by the article (Van der Broek et al., 2018), whose model simulates individual life histories from birth to death, with and without breast cancer, in the presence and in the absence of screening and treatment, facing the problem of risk based screening and treatment by using MISCAN-Faia microsimulation model. The MISCAN is a computer program introduced in (Habbema et al., 2018) based on Monte Carlo simulation, yielding the effect of screening on morbidity and mortality on the population.

In this paper, after the introduction of a dynamical model describing the evolution of the population in the five stages, the identification of model parameters is obtained by using real data of the female population of Lazio (region of Italy). Then, three containment measures are considered, corresponding to non invasive prevention, like echography and mammography screening, first level actions, corresponding to chemotherapy, and second level actions, corresponding to surgery. In the framework of optimal control theory it is possible to propose the best resource allocation strategy aiming at reducing the number of population at stage 3 and 4 as well as the number of individuals dead for breast cancer.

The paper is organized as follows. In Section 2 the mathematical model is introduced and the optimal control is determined, considering also resource constraints; in Section 3, first the model parameters are identified and successively optimal control is implemented and applied. Conclusions and future developments are outlined in Section 4.

2 MATERIALS AND METHODS

In this paper, the diffusion of breast cancer is studied at population level, considering groups of subjects homogeneous with respect to their health condition. As already pointed out in the introduction, in the population, beside the healthy people, only two groups of individuals with breast cancer are introduced, simplifying the description of the dynamics of the population with tumor; other two compartments of dead subjects are considered, distinguishing between those dead as consequence of tumor and those who died from other causes than breast cancer. These two compartments are useful for the identification step.

In the following section, a compartmental model is proposed, introducing control action aiming at reducing the number of subjects affected by this pathology. Optimal control appears to be the suitable framework in which determine the best resource allocation strategy considering limitations, both from economic and logistic point of view.

2.1 Mathematical Model

The population is partitioned into five compartments X_i , $i = 1, \dots, 5$, the first three corresponding to alive subjects in different condition with respect to the diagnosis of tumor:

- $X_1(t)$ represents the number of subjects with no diagnosis of breast cancer at time t ;
- $X_2(t)$ corresponds to number of individuals that at time t are in stage 0, 1 and 2 of the official classification of breast cancer patients;
- $X_3(t)$ includes the subjects that at time t are in the more severe condition of breast cancer corresponding to stages 3 and 4.

Other two compartments of removed subjects are introduced, being useful in the parameters' identification step:

- $X_4(t)$ represents the number of subjects dead at time t for other causes than breast cancer;
- $X_5(t)$ represents the number of subjects dead at time t due to breast cancer.

The compartments X_1 , X_2 and X_3 represent possible stages of human condition with respect to breast cancer. It is assumed that, also without specific control action, it is possible for a subject to recover, and therefore to transfer, from compartment X_2 , and even from X_3 , to X_1 . Be the parameter c_0 the rate of newborn individuals in X_1 ; c_1 is the rate at which an individual in the X_1 state can receive a positive diagnosis of breast cancer, and therefore transfer in the X_2 class. If c_1 is very small, at least less than the average life time, it means that a subject does not receive a positive diagnosis for life. The parameters c_2 and c_3 represent, respectively, the natural recovery from the X_2 and X_3 compartments to X_1 ; c_4 is the rate of transition from X_2 to X_3 , corresponding to tumour stage aggravation. In addition to these evolution parameters, the terms $\frac{d_i}{t^{4/5}}$, $i = 1, \dots, 3$ account for the death rates for classes X_i respectively, not connected with tumour evolution, slightly decreasing on time. The term $\frac{D}{t^{4/5}}$ is the rate of death due directly to tumour, assumed occurring from the X_3 condition only. Both death rates, due to tumor $\frac{D}{t^{4/5}}$ and to natural causes $\frac{d_i}{t^{4/5}}$, $i = 1, \dots, 3$, are modeled by a decreasing exponential analytical function, in accordance with the development of medical technologies and the improvement of the quality of life over the years.

Finally, Z_i , $i = 1, 2, 3$ denote the rate of possible new incomers in the compartments X_i respectively.

With these positions, and setting $C_i = c_i + \frac{d_i}{t^{4/5}}$, $i = 1, 2, 3$, the dynamical matrix:

$$A_{11}(t) = \begin{pmatrix} c_0 - C_1 & c_2 & c_3 \\ c_1 & -c_4 - C_2 & 0 \\ 0 & c_4 & -C_3 - \frac{D}{t^{4/5}} \end{pmatrix}$$

describes the evolution of the states X_1 , X_2 and X_3 in absence of control actions according to the equations

$$\begin{pmatrix} \dot{X}_1(t) \\ \dot{X}_2(t) \\ \dot{X}_3(t) \end{pmatrix} = A_{11}(t) \begin{pmatrix} X_1(t) \\ X_2(t) \\ X_3(t) \end{pmatrix} + \begin{pmatrix} Z_1 \\ Z_2 \\ Z_3 \end{pmatrix}$$

In addition, the evolution of the removed subjects is given by:

$$\begin{pmatrix} \dot{X}_4(t) \\ \dot{X}_5(t) \end{pmatrix} = A_{21}(t) \begin{pmatrix} X_4(t) \\ X_5(t) \end{pmatrix}$$

once the matrix

$$A_{21}(t) = \begin{pmatrix} \frac{d_1}{t^{4/5}} & \frac{d_2}{t^{4/5}} & \frac{d_3}{t^{4/5}} \\ 0 & 0 & \frac{D}{t^{4/5}} \end{pmatrix}$$

is introduced.

The distinction between the evolution of the number of people who died from other causes than breast

cancer or as consequences of breast cancer is introduced to support the identification step, as will be shown in Section 3.

Introducing the state vector $X(t) = (X_1(t) \ X_2(t) \ X_3(t) \ X_4(t) \ X_5(t))^T$, and defining the block matrix:

$$A(t) = \begin{pmatrix} A_{11}(t) & 0_{3 \times 2} \\ A_{21}(t) & 0_{2 \times 2} \end{pmatrix}$$

in which $0_{i \times j}$ denotes the $i \times j$ matrix with all entries equal to zero, the system evolution, without any control action, can be described in compact form as follows:

$$\dot{X}(t) = A(t)X(t) + Z \tag{1}$$

with $Z = (Z_1 \ Z_2 \ Z_3 \ 0 \ 0)^T$.

Three controls u_1, u_3 and u_3 are introduced. u_1 represents non invasive actions able to identify tumor in the first diagnosis as well as possible worsening of the situation; in the first case, u_1 is the prevention involving subjects in the X_1 category, still unaware of the possible presence of tumor. After the regular screening, part of individuals with positive diagnosis are transferred in group X_2 and another part in X_3 . Non invasive control is applied also to the patients in X_2 and, in case of increased severity of the tumor revealed, they are transferred to class X_3 . With P_{ij} is indicated in compact form the product of the percentage of subjects transferring from the compartment X_j under the control $u_i, i, j = 1, 2, 3$ and the rate at which this transfer occurs; the quantity P_{11} weighting the transfer from compartment X_1 to X_2 and X_3 is split in \bar{P}_{11} and $P_{11} - \bar{P}_{11}$, respectively.

Other two invasive controls are added, $u_2(t)$ and $u_3(t)$; they are applied when the subject begins the treatment process and therefore they can be considered once the control u_1 is applied; the efficacy of these treatments u_j is indicated by $B_j, j = 1, 2, 3$. Therefore, by defining the control vector $U(t) = (u_1(t) \ u_2(t) \ u_3(t))^T$ and the matrices:

$$G_1(U) = \begin{pmatrix} -P_{11}u_1 & P_{22}u_2 & P_{33}u_3 \\ \bar{P}_{11}u_1 & -P_{12}u_1 & -P_{22}u_2 \\ (P_{11} - \bar{P}_{11})u_1 & P_{12}u_1 & -P_{33}u_3 \end{pmatrix}$$

$$G_2(U) = \begin{pmatrix} 0 & B_2u_1u_2 & B_3u_1u_3 \\ 0 & -B_2u_1u_2 & 0 \\ 0 & 0 & -B_3u_1u_3 \end{pmatrix}$$

and

$$G(U) = \begin{pmatrix} G_1(t) + G_2(t) & 0_{3 \times 2} \\ 0_{2 \times 3} & 0_{2 \times 2} \end{pmatrix}$$

the dynamical system representing the possible evolution of the number of people in the five compartments is

$$\dot{X}(t) = A(t)X(t) + G(U)X(t) + Z \tag{2}$$

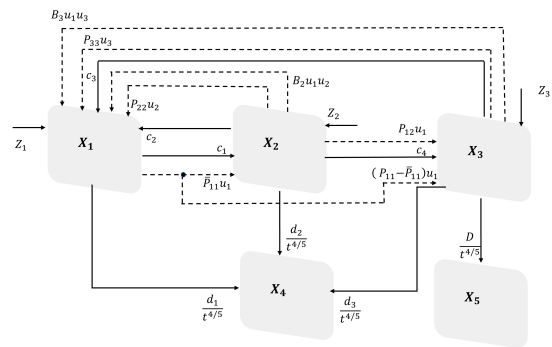

Figure 1: Block diagram of the proposed model.

In Fig.1 it is shown the proposed partition of the female population indicating with bold arrows the natural transition between compartments and with the dotted ones the forced transfer due to external control actions.

2.2 Optimal Control

Prevention is the best strategy to detect as soon as possible breast cancer that, if identified and treated in advance, could allow complete recover, avoiding invasive treatments. In this section, by considering the economic, cultural and logistical limitations, it will be proposed a suitable allocation strategy in the framework of optimal control theory. A cost index is introduced:

$$J(X, U) = \frac{1}{2} \int_{t_i}^{t_f} (\alpha_1 X_3^2(t) + \alpha_2 X_5^2(t) + \sum_{j=1}^3 \beta_j u_j^2(t)) dt$$

where $\alpha_i, i = 1, 2, 3$ and $\beta_j, j = 1, 2, 3$ are the weights respectively for the states to be minimized and the controls. The goal of this choice is to reduce the number of severe cases and of deaths due to tumor. The controls u_i are assumed bounded between 0 (no control) and 1 (maximum effect)

$$0 \leq u_i \leq 1 \quad i = 1, 2, 3 \tag{3}$$

By denoting with $\lambda(t) = (\lambda_1(t) \ \lambda_2(t) \ \lambda_3(t) \ \lambda_4(t) \ \lambda_5(t))^T$ the costate function, the Hamiltonian is introduced:

$$H(X, U, \lambda) = \frac{1}{2} (\alpha_1 X_3^2(t) + \alpha_2 X_5^2(t) + \sum_{j=1}^3 \beta_j u_j^2(t)) + \lambda^T(t) \dot{X}(t) \tag{4}$$

The Pontryagin principle can be applied yielding necessary conditions:

$$U^o(t) = \min H(X, U, \lambda), \tag{5}$$

among all the admissible controls u_i in $[0, 1]$, $i = 1, 2, 3$, with the λ satisfying the costate equations:

$$\dot{\lambda}(t) = - \left. \frac{\partial H}{\partial X} \right|^T \quad (6)$$

thus yielding:

$$\begin{aligned} \dot{\lambda}_1(t) &= -[\lambda_1(c_0 - C_1 - P_{11}u_1) + \lambda_2(c_1 + \bar{P}_{11}u_1) \\ &+ \lambda_3(P_{11} - \bar{P}_{11})u_1 + (\lambda_4 - \lambda_1)\frac{d_1}{t^{4/5}}] \end{aligned}$$

$$\begin{aligned} \dot{\lambda}_2(t) &= -[\lambda_1(c_2 + P_{22}u_2 + B_2u_1u_2) \\ &- \lambda_2(c_4 + C_2 + P_{12}u_1 - B_3u_1u_2 - P_{22}u_2) \\ &+ \lambda_3(P_{12}u_1 + c_4) + (\lambda_4 - \lambda_2)\frac{d_2}{t^{4/5}}] \end{aligned}$$

$$\begin{aligned} \dot{\lambda}_3(t) &= -\alpha_1x_3 - [\lambda_1(c_3 + P_{33}u_3 + B_3u_1u_3) \\ &- \lambda_3(P_{33}u_3 \\ &+ c_3 + \frac{D}{t^{4/5}} + B_3u_1u_3) \\ &+ (\lambda_4 - \lambda_3)\frac{d_3}{t^{4/5}} + \lambda_5\frac{D}{t^{4/5}}] \end{aligned}$$

$$\dot{\lambda}_4(t) = 0$$

$$\dot{\lambda}_5(t) = -\alpha_2x_5$$

Being not fixed the final state, all the costate functions are equal to zero in the fixed t_f . The necessary condition (5) with the constraint (3) can be implemented by using the control equation $0 = \left. \frac{\partial H}{\partial u} \right|^T$:

$$\begin{aligned} 0 = \frac{\partial H}{\partial u_1} &= \beta_1u_1 + (\lambda_1B_2 - \lambda_2B_2)u_2X_2 + \lambda_1B_3u_3X_3 \\ &- \lambda_1P_{11}X_1 + \lambda_2\bar{P}_{11}X_1 - \lambda_2P_{12}X_2 \\ &+ \lambda_3(P_{11} - \bar{P}_{11})X_1 + \lambda_3P_{12}X_2 \quad (7) \end{aligned}$$

$$\begin{aligned} 0 = \frac{\partial H}{\partial u_2} &= \beta_2u_2 + \lambda_1P_{22}(X - 2 - X_3) \\ &+ (\lambda_1B_2X_2 + \lambda_1B_2X_1 + \lambda_2B_3X_2)u_1 \quad (8) \end{aligned}$$

$$\begin{aligned} 0 = \frac{\partial H}{\partial u_3} &= \beta_3u_3 + (\lambda_1 - \lambda_3)B_3u_1X_3 \\ &+ (\lambda_1 - \lambda_3)P_{33}X_3 \quad (9) \end{aligned}$$

and successively applying the saturation due to (3). From equation (8), the control u_2 can be expressed as function of u_1 :

$$\begin{aligned} u_2 &= -\frac{\lambda_1P_{22}}{\beta_2}(X_2 - X_3) \\ &- \frac{\lambda_1B_2X_2 + \lambda_1B_2X_1 + \lambda_2B_3X_2}{\beta_2}u_1 \\ &= f_2(u_1) \quad (10) \end{aligned}$$

From equation (9), also the control u_3 can be expressed as function of u_1 :

$$u_3 = \frac{\lambda_3 - \lambda_1}{\beta_3}(B_3X_3u_1 + P_{33}X_3) = f_3(u_1) \quad (11)$$

By substituting (10) and (11) into (7), it is possible to solve with respect to u_1 , denoting by \bar{u}_1 the solution. By substituting \bar{u}_1 into $f_2(u_1)$ and $f_3(u_1)$, \bar{u}_2 and \bar{u}_3 are obtained, respectively. Taking into account the constraint in (3), the optimal controls are:

$$u_1^o(t) = \min(\max(\bar{u}_1(t), 0), 1)$$

$$u_2^o(t) = \min(\max(\bar{u}_2(t), 0), 1)$$

$$u_3^o(t) = \min(\max(\bar{u}_3(t), 0), 1)$$

3 NUMERICAL RESULTS

To choose the parameters of mathematical model proposed in (2) real data regarding the Lazio region (in the center of Italy), are used. In the considered period, about 1980–2020, greater attention from the institutions and sensitivity of the population certainly contributed to tackling the problem of breast cancer with growing awareness, even if in discontinuous way, due, for example, to economic/social conditions. Therefore, the considered data are the effects of applied policies and behaviors, such as screening campaigns, sanitary resources, economic and social conditions. These applied control measures are not identified and the parameters of the proposed model are determined trying to get the general trends and the order of amplitude of the considered quantities. The data are retrieved from ISTAT's "Health for All" database, (ISTAT, 2023), specifically:

- Female population data from 1982 to 2020;
- Female prevalence data from 1980 to 2016;
- Female number of death due to tumor from 1990 to 2018;
- Female deaths due to non-tumor-related causes from 1990 to 2018.

It must be stressed that only in the last years, especially with COVID-19 emergency, data collection has becoming more detailed; therefore, in this case, also the information carried on by the trend in the annual number of deaths for breast tumor is used for the model parameters identification and has suggested the introduction of the compartment X_5 in the model. The parameters are chosen to minimize the difference between the model output and the actual available data:

$$\begin{aligned} X(0) &= (259 \cdot 10^4 \quad 1500 \quad 4000 \quad 17500 \quad 930)^T, \\ Z &= (10^4 \quad 3 \cdot 10^2 \quad 10^2 \quad 0 \quad 0)^T, \\ d_1 &= d_2 = d_3 = 0.045, \quad D = 0.055, \\ c_1 &= 5 \cdot 10^{-4}, \quad c_2 = 7.8 \cdot 10^{-4}, \\ c_3 &= 2.5 \cdot 10^{-3}, \quad c_4 = 0.99 \quad (12) \end{aligned}$$

In Figs. 2 – 3 it is shown the number of dead subjects for breast tumor and the number of dead individuals for causes independent on tumor respectively.

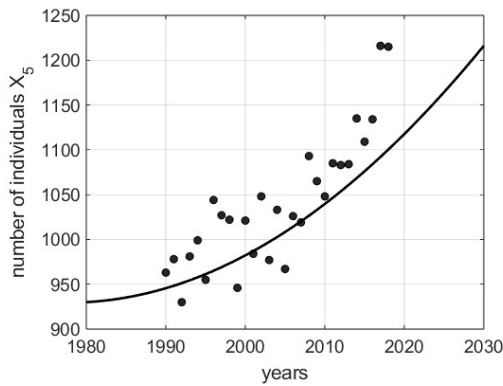

Figure 2: Number of dead individuals for causes related with breast cancer: the points are the real values referring to the Lazio (Italy) region, whereas the continuous line is the trend of the identified model.

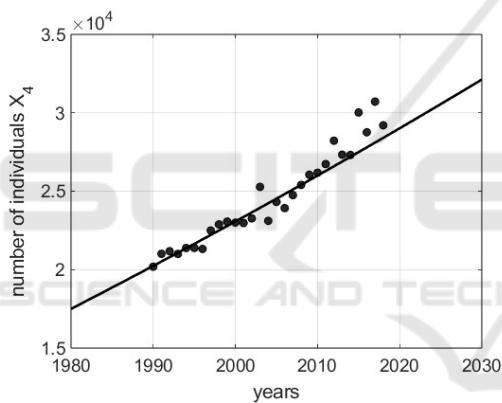

Figure 3: Number of dead individuals for causes not related with breast cancer: the points are the real values referring to the Lazio (Italy) region, whereas the continuous line is the trend of the identified model.

In both cases, especially up to data regarding 2013, the model states X_4 and X_5 (without the introduction of control) adequately track the real data. In the proposed model for simplicity in X_2 are collected the number of cases at stages 0, 1 and 2, whereas the more severe cases are in X_3 ; the sum of all diagnosed tumor real cases is compared to the sum $X_2 + X_3$, thus showing the trends of Fig. 4, resulting acceptable up to 2005. Again, the not uniform fitting in all the considered period is due to the adoption, in this phase, of a not controlled model, whereas in the real data the effects of some kind of control could be present. Once the model parameters are determined to represent the typical trends of a western region, the control actions are introduced. As far as the parameters regarding the effectiveness of the control actions the following

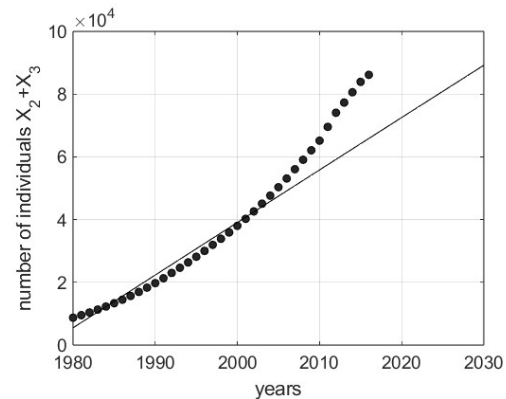

Figure 4: Number of dead individuals with a positive diagnosis of breast cancer, $X_2(t) + X_3(t)$: the points are the real values referring to the Lazio (Italy) region, whereas the continuous line is the trend of the identified model.

choices are taken:

$$\begin{aligned} B_2 &= 0.95, & B_3 &= 0.8, \\ P_{11} &= 1.5 \cdot 10^{-3}, & P_{12} &= 8 \cdot 10^{-2}, & \bar{P}_{11} &= 7 \cdot 10^{-4}, \\ P_{22} &= 0.97, & P_{33} &= 10^{-5} \end{aligned} \quad (13)$$

With these choices it is modeled the effectiveness of the control in improving the number of positive diagnosis to start the treatments as soon as possible.

The optimal controls $u_i^o, i = 1, 2, 3$ are obtained by choosing for the weights in the control index the values:

$$\begin{aligned} \alpha_1 &= 10^{-4}, & \alpha_2 &= 0.09, \\ \beta_1 &= 300, & \beta_2 &= 300, & \beta_3 &= 900 \end{aligned} \quad (14)$$

The optimal control U^o depends on these choices aiming at decreasing the number of patients in X_3 and of dead individuals in X_5 , allocating properly the limited resources; the weights β_1 of u_1 and β_2 of u_2 are one third of the corresponding value β_3 trying to guide the solution to privilege controls u_1 and u_2 , rather than more severe and invasive treatment u_3 . In Fig.5 it is shown the trend of the three optimal controls $u_i^o, i = 1, 2, 3$ when the parameters are chosen as in (3) and (14). Note the requirement of the prevention u_1^o in all the control period, whereas control u_2^o is a little bit relaxed to increase in the last ten years of control when, on the other hand, it can be decreased the effort for the severe treatments. The corresponding state evolutions are shown in Fig. 6 Note that with the application of controls the number of individuals with a positive diagnosis in compartment X_2 is improved, being the effects of early diagnosis that allows the start of effective treatments; moreover, the convenience of the application of containment measures can be appreciate both noting the reduced number of dead individuals X_5 and of the total number of subjects with

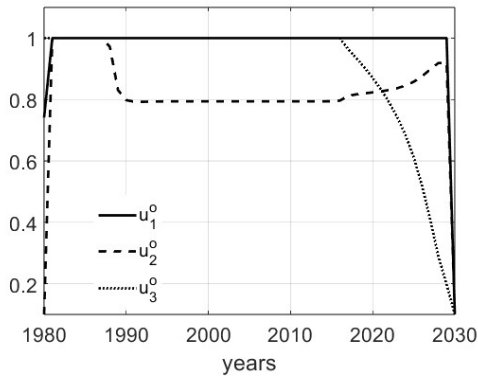

Figure 5: Trend of the optimal controls u_i^o , $i = 1, 2, 3$ when the parameters are chosen as in (3) and (14).

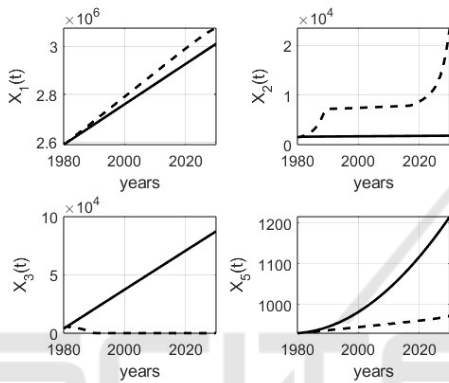

Figure 6: Trend of the optimal states X_1^o , X_2^o , X_3^o , X_5^o when the parameters are chosen as in (3) and (14); the continuous lines represent the evolutions in absence of control, whereas the dashed lines are the effects of the optimal controls.

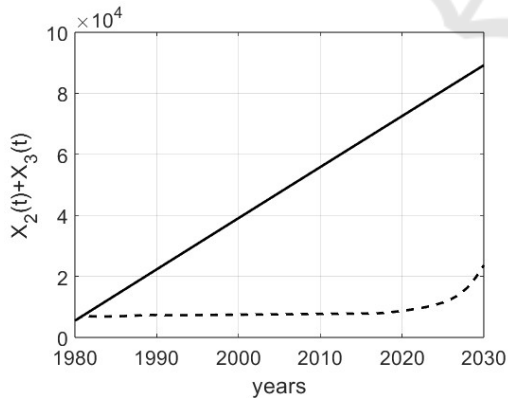

Figure 7: Trend of $X_2(t) + X_3(t)$ when the parameters are chosen as in (3) and (14); the continuous line represents the evolution in absence of control, whereas the dashed one is the effect of the application of the optimal controls.

a positive diagnosis, as shown in Fig.7. The evolution of X_4 , the number of individuals dead for reasons not related to tumor, is not shown being, obviously, the same, without and with control.

Different choices of the weights α_i , $i = 1, 2$ and β_j , $j = 1, 2, 3$ in the cost index can lead to strongly different resource allocations and states evolution; as a further example, it is proposed an alternative to the choice for the weights in (14); in particular, it is augmented the ratio between the values of the β_i , $i = 1, 2, 3$ and those of α_j , $j = 1, 2$:

$$\begin{aligned} \alpha_1 &= 10^{-7}, & \alpha_2 &= 10^{-7}, \\ \beta_1 &= \beta_2 = \beta_3 = 1, \end{aligned} \quad (15)$$

With this choice the controls are weighed without privileging one with respect to the other. The obtained optimal controls u_i^o , $i = 1, 2, 3$ are shown in Fig. 8, in which it is evident the fundamental role of prevention u_1^o and the limited action of u_3^o , the severe treatment. For this simulation it is interesting to show the evolution of the sum of subjects with a positive diagnosis of breast cancer, in Fig.8.

Note that the trend of $X_2^o(t) + X_3^o(t)$ with the application of control becomes higher up to year 2020 with respect to the case in which no action is applied, Fig. 9; successively, the relation among these two evolutions is reverted. This means that the prevention allows early detection and, therefore, an increase in the number of diagnosed individuals, but the treatments allow successively a decrease in $X_2(t) + X_3(t)$. The effectiveness of this approach is further confirmed considering the trend of the number $X_5(t)$ of individuals dead for breast cancer: the application of the optimal control decreases this number in all the simulate control period, see Fig. 10.

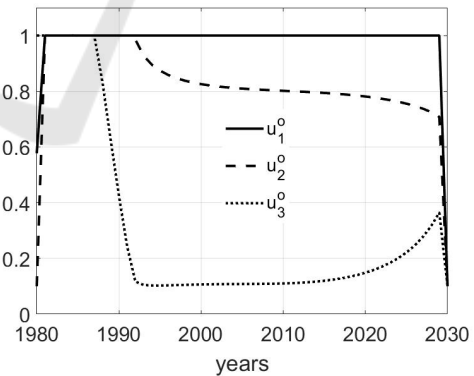

Figure 8: Trend of the optimal controls u_i^o , $i = 1, 2, 3$ when the parameters are chosen as in (3) and (15).

4 CONCLUSIONS

In the medical field, thanks to the developments in the treatment of breast cancer, even people with positive diagnoses have a good chance of a complete recovery, provided they have a timely diagnosis. However,

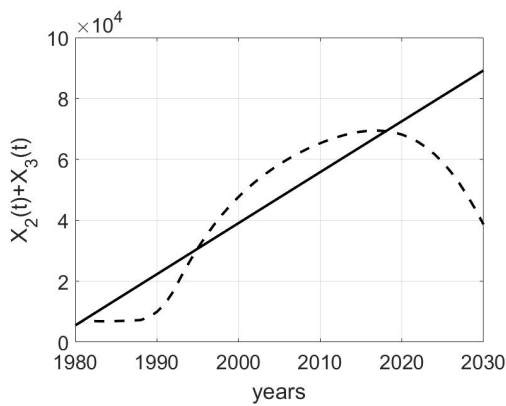

Figure 9: Trend of $X_2(t) + X_3(t)$ when the parameters are chosen as in (3) and (15); the continuous line represents the evolution in absence of control, whereas the dashed one is the effect of the application of the optimal controls.

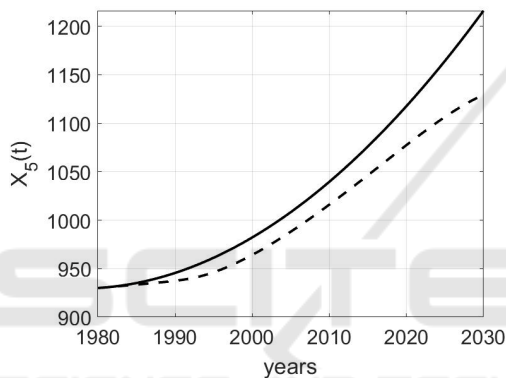

Figure 10: Trend of $X_5(t)$ when the parameters are chosen as in (3) and (15); the continuous line represents the evolution in absence of control, whereas the dashed one is the effect of the application of the optimal controls.

economic and logistical resources, combined with a lack of awareness of the importance of prevention, do not always allow the problem to be tackled effectively. The introduction of an epidemiological model, identified with reference to a western population, allows, within the optimal control theory, to plan an adequate allocation of resources to reduce mortality and severe cases. The novelty and advantages of such approach may be listed as follows:

- it is proposed an *epidemiological model* for the spread of breast cancer customized on a specific population;
- the availability of such a model yields a medium-term forecast at population level of the disease course under different control conditions;
- the application of optimal control allows an adequate allocation of limited resources.

Future developments will regard:

- a deeper model parameter identification: this aspect requires the analysis of the containment measures applied starting from 1980 and therefore the use of this information in the identification step;
- an accurate analysis of real data to define the average effectiveness of the introduced controls, as well as their limits in facing the breast cancer; this aspect could allow a more accurate choice of control parameters;
- consider data regarding female populations with different sanitary systems and habits, so to apply the proposed control strategy;
- a deep study of *over diagnosis* versus the importance of prevention, so to avoid the detection of not life-threatening and, at the same time, preserve the fundamental role of screening.

REFERENCES

Alkabban, M. and Ferguson, T. (2022). Breast cancer. In <https://www.ncbi.nlm.nih.gov/books/NBK482286/>.

American Cancer Society (2023). All about cancer. In <https://www.cancer.org/cancer/types/breast-cancer/about/types-of-breast-cancer.html>.

Choi, L. (2022). Breast cancer. In <https://www.msdmanuals.com/professional/gynecology-and-obstetrics>.

City of Hope (2023). Breast cancer stages. In <https://www.cancercenter.com/cancer-types/breast-cancer/stages>.

Fox, S., Speirs, V., and Shaban, A. (2022). Male breast cancer: an update. In *Virchows Arch*.

Habbema, J., Van Oortmarssen, G., Lubbe, J., and Van der Maas, P. (2018). The miscan simulation program for the evaluation of screening for disease. In *Medical Decision Making*.

Huang, S., H, P., and Lakowski, T. (2021). Predicting breast cancer drug response using a multiple-layer cell line drug response network model. In *BMC Cancer*.

ISTAT (2023). Istituto nazionale di statistica. In <https://www.istat.it/>.

Kolak, A., Kaminska, M., sygit, K., Budny, A., Surdyka, D., Kukielka-Budny, B., and Burdan, F. (2017). Primary and secondary prevention of breast cancer. In *Annals of Agricultural and Environmental Medicine*.

Tang, T., Shah, Z., Bonyah, E., Jan, R., Shutaywi, M., and Alreshidi, N. (2022). Modeling and analysis of breast cancer with adverse reactions of chemotherapy treatment through fractional derivative. In *Computational and Mathematical Methods in Medicine*.

Van der Broek, J., Van Ravestejn, N., Heijnsdijk, E., and De Koning, H. (2018). Simulating the impact of risk-based screening and treatment on breast cancer outcomes with miscan-fadia. In *Medical Decision Making*.

WHO (2023). World health organization. In <https://www.who.int/>.