

RESERVE THIS SPACE

Contribution of reactive extrusion to technological and scientific challenges of eco-friendly circular economy.

Valerie Massardier^{1*}, Alessia Quitadamo^{1,2}

¹Université de Lyon, F-69003, INSA de Lyon, F-69621, Villeurbanne, France, CNRS, UMR 5223, Ingénierie des Matériaux polymères.

²Sapienza, University of Rome, Dep. of Chemical and Material Engineering, via Eudossiana 18, 00184 Rome, Italy

*valerie.massardier@insa-lyon.fr

Abstract Nowadays, development and production in eco-friendly circular economy are themes of great importance. Concerning optimization of materials production, reactive extrusion (REX) is well established, using extruder as a chemical reactor. Biopolymers and recycling are two interesting fields in which REX can be used. In fact, through REX, biopolymers can be produced from monomers, modified (grafting...) or chemically blended with other polymers. Moreover, chemical reactions can occur between polymers and additives in order to optimize post-consumer polymer recycling. The first part of this chapter will focus on REX modellization, useful to optimize REX parameters, in agreement with eco-friendly circular economy domain. The second part of this chapter will focus on the production process of bio-derived polymers, their blends and composites, as well as recycling of post-consumer polymers.

RESERVE THIS SPACE

Introduction

During last decades, reactive extrusion (REX) seemed to achieve increasing interest in order to answer some challenges and objectives of ecofriendly extrusion. Indeed, extrusion is one of the most commonly used production processes for polymer materials, finding its advantages in a continuous process with short residence times, high mixing capacity and versatility [1]. In this context, the possibility to obtain chemical reaction in the extruder valorizes this process, considering the extruder as a horizontal chemical reactor in which reactions are solvent free. Those benefits, added to traditional extruder features, are related to energy efficiency as well as reduction of dispersion of volatile organic compounds. As a consequence, REX is helpful in order to project production processes in the field of ecofriendly circular economy.

Many studies have been carried out in order to analyse the efficiency of REX in two interesting fields of circular economy: biopolymers and recycling. In this context, extruders can be reactors for several processes, such as:

- Bulk polymerization for synthesis of high molecular weight (linear, branched, cross-linked) polymers from virgin or recycled monomers.
- Modifications by grafting, functionalization of polymers production by functional molecules. The resulting polymer can be useful for in-situ compatibilization of polymer blends, for example obtained after non perfect sorting of post-consumer wastes.
- Reactive blending to obtain compatibilized polymer blends (reactions at the interface) by in situ polymerization of one of both phases. In this case, copolymers needed to improve compatibilization between two immiscible polymers are produced through chemical reaction during mixing in extrusion chambers. The main advantage is that chemical reactions are located only at the interface, at least at the beginning, where the copolymer is produced. In this way, it is possible to overcome the slow diffusion step necessary for production of copolymers, which are used to compatibilize blends. [2]

REX is more and more used to process bio-based materials, associated with lower depletion of non-renewable materials. Moreover, REX can be used either to carry out in-situ synthesis of compatibilizers for post-consumer thermoplastic blends, to regenerate polymer properties by chain coupling or even to depolymerize polymers.

Reactive Extrusion Modelling

In order to optimize the process and produce materials in an eco-friendly circular economy, reactive extrusion process modellization is a relevant tool. In fact, extrusion, and reactive extrusion in particular, are very sensitive at process parameter variations. The applications of models facilitate the finding of optimized process conditions, reducing material wastes and energy consumption to obtain the expected conversion. Some examples of process complexity are listed above:

Flow rate variation affects residence time, die pressure, pressure flow rate and heat transfer coefficients.

Residence time has a direct impact on mixing capacity and conversion rate.

Mixing capacity, related to screw speed, residence time and pressure flow rate, influences heat transfer coefficients.

Kinetic of reaction, depending on melt temperature, free radical concentration and freezing effect, affects conversion rate, average molecular rate melt temperature [3].

Touhtouh et al. analyzed the influence of processing parameters on dynamic covalent reorganization of biodegradable polycaprolactone and poly(ethylene-co-vinyl alcohol) blends [4]. The main idea of dynamic covalent chemistry is based on the possibility to form and break covalent bonds to obtain the most thermodynamically stable product. In particular, the optimized production of poly(ethylene-co-vinyl alcohol)-g-polycaprolactone is affected by many factors (such as crystallinity, adhesion properties...), as a function of processing parameters. Reaction modellizations were applied to analyze the influence of reaction parameters on reactions that can develop in the extruder. For example, the effect of reaction time was evaluated, corroborated through Scanning Electron Microscopy (SEM). Indeed, the higher reaction time, the lower particle size. The use of SnOct₂, used as catalyst for transesterification reaction, displayed a reduction from 100 µm to 25 µm of the dispersed phase average diameter when increasing reaction time from 30 to 120 min respectively (figure 1).

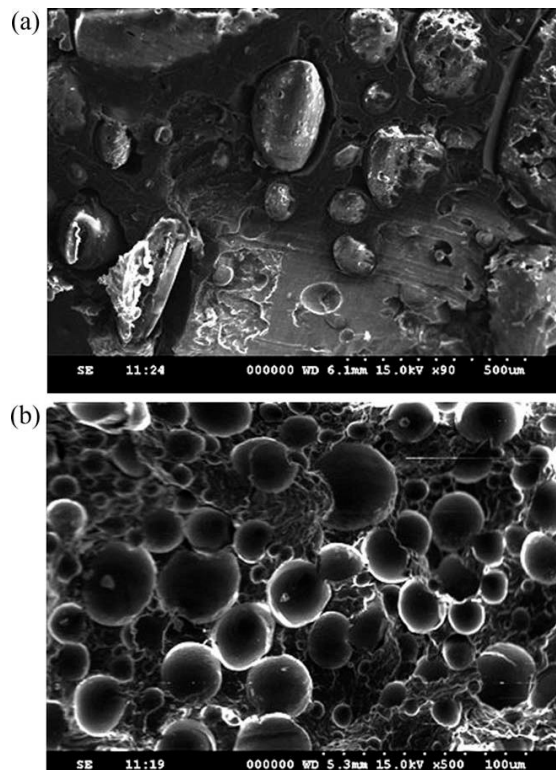

Figure 1: SEM analysis of EVOH-g-PCL synthesized with SnOct₂ at 30 min (a) and 120 min (b) reaction times. Reprinted with permission from reference 4, Copyright © 2011 Wiley Periodicals, Inc.

Diffusion control for immiscible polymers takes place in the reaction initial phase, displaying typical immiscible polymer systems, composed of a nodular secondary phase in the continuous one. The morphology evolution agrees with reactive systems producing copolymers acting as emulsifiers. As a consequence, a size reduction of the dispersed phase and an auto acceleration of reactions are displayed.

The extruder is considered as a continuous chemical reactor, in which polymers with different viscosities are mixed, chemical reactions develop and heat transfer phenomena occur [5]. The first attempt in modelling reactive extrusion is based on an engineering approach, such as residence time distribution (RTD) and flow conditions described for an ideal chemical reactor. Continuous flow Stirred Tank Reactor (CSTR), Plug Flow Reactor (PFR) in presence or not of axial dispersion.

Twin-screw extruders are characterized by a very complex flow. As a consequence, particles are submitted to different residence times. Normally, the number of particles staying in the extruder in a time interval can be expressed as:

$$E(t) = f(t)dt \quad (1)$$

E(t) expression can be evaluated experimentally by the addition of inert (called tracer) able to vary some easy observable properties, such as electrical conductivity, γ radiation, UV fluorescence or colour variation. At $t=0$, a known amount of tracer is filled in the extruder, and its concentration is registered as a function of time in the outgoing product [6-7]. RTD is one of the most representative properties of a chemical reactor in order to obtain the desired conversion. As a consequence, RTD is used to set optimized process parameters. Flow modelling can be characterized by different levels of accuracy, depending on the objectives of the modellization:

1. The simplified one-dimensional analysis is based on the presence of a unique velocity component. This method is useful to plot flow rate evolution with pressure gradient.
2. The two-dimensional analysis considers the transverse and longitudinal flow, still ignoring the velocity according to z.
3. The three-dimensional analysis considers the actual geometry and kinematics, obtaining complex numerical evaluation.

An example of reactive extrusion modelling for bio-derived polymers has been proposed by Becquart et al [8]. They analysed the chemical modification of poly(ethylene-co-(vinyl alcohol)) by grafting of poly(ϵ -caprolactone). They choosed a phenomenological kinetic model in order to optimize the effect of initiator, alcohol and caprolactone concentrations, in order to correctly evaluate processing conditions.

The adopted kinetic model was

$$Rp = -\frac{d[Cl]}{dt} = k * [SnOct_2]_0^n * [OH]_0^a * [Cl] \quad (2)$$

in which k is the kinetic constant, [SnOct₂] is the initiator concentration, [OH] is the alcohol concentration and [Cl] is the ϵ -caprolactone concentration. n and a parameters are exponents without chemical or physical mechanism correlation.

Kinetic parameters have been extrapolated from computer optimization, obtaining $k=4.005 \times 10^{-3}$, $n=0.64649$ and $a=4.08325$.

This model agrees with experimental data, making its use possible (figure 2).

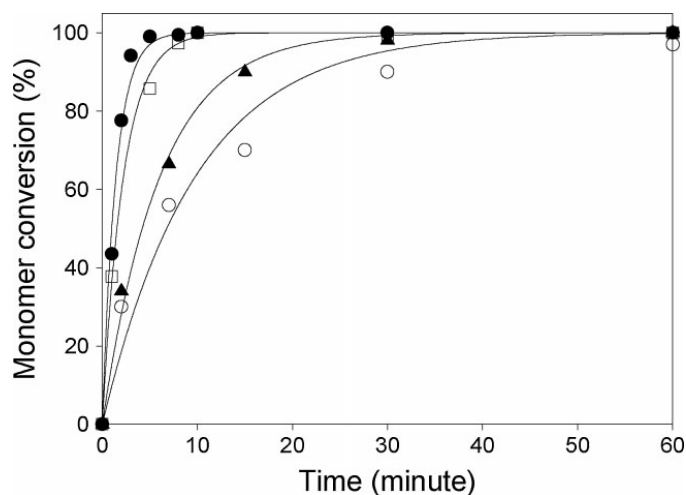

Figure 2: Monomer conversion during a synthesis of EVOH-g-PCL at $T=185^{\circ}\text{C}$. Solid lines are derived from equation 2, geometrical figures are experimental data. Reprinted with permission from reference 8, Copyright © 2009 Wiley WILEY-VCH Verlag GmbH & Co. KGaA, Weinheim.

The limit of this approach is the use of an ideal reactor and the complex possibility to generalize results. Consequently, another approach is based on a continuous mechanism composed of different coupled modules for reactive extrusion [3]:

- Module depending on processing conditions (e.g. co-rotating twin-screw extruder). In order to predict flow parameters, such as pressure, temperature, RTD etc, the software LUDOVIC (Logiciel pour l'Utilisation de DOubles VI Corotatives) has been developed. This software is a global model for extrusion process proposed by CEMEF and INRA.
- Module for chemical reaction. The complexity of kinetic components depends on which reaction is considered. For polymerization reactions, a common relationship between concentration and thermodynamic parameters follows Arrhenius' law. Conversely, degradation reactions involve many phenomena, increasing the complexity of kinetic expressions.

- Module for significant rheological variations. Polymerization reactions are characterized by viscosity variations from $10^{-3}\text{Pa}\cdot\text{s}$ for monomers to $10^3\text{Pa}\cdot\text{s}$ for polymers. In these cases, viscosity variations are not negligible, but other reactions are characterized by minor viscosity variations.

Banu et al. proposed a modelling approach for L-lactide ring opening polymerization by reactive extrusion [9]. A kinetic model for L-lactide ring opening polymerization was developed to predict monomer conversion and average molecular weight of the polymer. LUDOVIC package was used to analyse flow and mixing characteristics in reactor, useful for modelling extrusion process.

Firstly, a kinetic analysis was modelled, $\text{SnOct}_2/\text{TPP}$ initiated the reaction and a good analysis between data and model was obtained (figure 3).

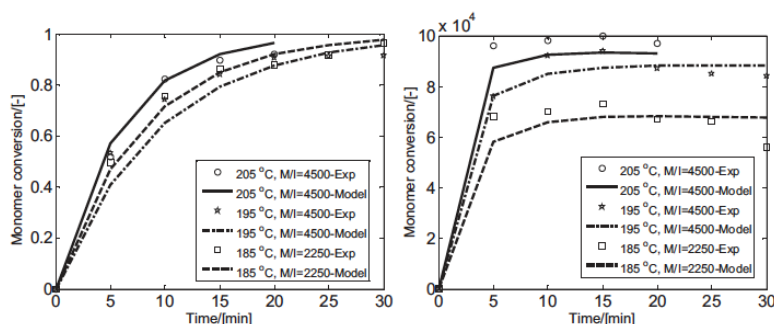

Figure 3: Calculated vs. experimental monomer conversion (left) and number average molecular weight (right). Reprinted with permission from reference 9, Copyright © 2010 WILEY-VCH Verlag GmbH & Co. KGaA, Weinheim.

Then, LUDOVIC software was used to obtain a mathematical model of the L-lactide reactive extrusion process. Two flow models have been developed starting from RTD evaluation: the first one based on axial dispersion (AD) and the second one based on the presence of perfectly mixed and plug flow zone series (Compartment model). A good agreement between calculated and experimental data was obtained (table 1), confirming the validity of modelling application. In fact, monomer conversion and number-average molecular weight derived from experimental evaluation seemed to be very close to values obtained with modelling approaches coupled with kinetic models.

Table 1 : Experimental and predicted polymer characteristics for M/I=2250 (Monomer to Initiator molecular ratio in the feed). Reprinted with permission from reference 9, Copyright © 2010 WILEY-VCH Verlag GmbH & Co. KGaA, Weinheim.

Mass flow rate, [kg/h]	Screw speed, [rpm]	Monomer conversion, [-]			Number-average molecular weight, [kg/kmol]		
		Exp	AD model	Compartment model	Exp	AD model	Compartment model
0.75	50	0.91	0.87	0.84	70000	73000	72500
0.75	200	0.82	0.80	0.74	63000	72000	71000
0.75	300	0.80	0.79	0.72	62000	71000	70000
1.25	50	0.87	0.78	0.75	65000	71500	71000
1.25	200	0.74	0.75	0.69	64000	71000	69000
1.25	300	0.68	0.63	0.58	60000	68000	67000
1.5	50	0.72	0.74	0.71	61000	71000	71000
1.5	200	0.65	0.60	0.55	59000	67000	66000

LUDOVIC software has also been used to estimate starch processing parameter through a viscous law [10]. Berzin et al. modelled starch transformation during extrusion, by coupling viscosity and thermomechanical treatment. In particular, a relationship between Specific Mechanical Energy (SME) and viscosity, as index of starch degradation, was evaluated. In fact, viscosity decreases when SME increases, in agreement with degradation of macromolecules. Theoretical results were closer to experimental ones when coupling SME and viscosity values, reducing the error from 30% (without coupling) to 10%.

Reactive Polymerization for bio-sourced or biodegradable polymers

Production of biodegradable polymers

Biopolymers assume an increasing key-role in plastic industry, as a possibility to substitute some of the traditional oil-based polymers [11]. In the perspective of greener routes for producing bio-derived polymers, considering the production process, the need of solvents, catalysts etc..., reactive extrusion seems to be effective in order to reduce environmental impacts also from a production process point of view. Bonnet et al. [12] compared a traditional bulk polymerization with reactive extrusion. In a twin-screw extruder, they obtained conversions of about 73% in 20 min with lanthanum catalyst (lanthanide trisborohydrides in particular), close to bulk polymerization results. The use of low toxicity metal-based catalysts and 130°C processing temperature instead of 180°C are also interesting conditions in

order to produce PLA macrocycles of high molecular weight via a continuous process (figure 4).

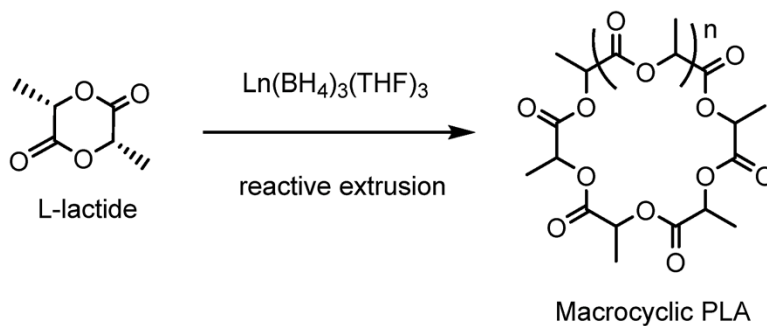

Figure 4 Macrocylic polylactide obtained by reactive extrusion. Reprinted with permission from reference 12, Copyright © The Royal Society of Chemistry 2015.

Another interesting process using alternative energies, such as microwaves, ultrasounds and laser, without metal catalysts is InnoRex, funded by the European Union Seventh Framework Programm (FP7/2007-2013) [13]. InnoREX project aims at favouring polymerization on a large scale in a twin screw extruder used for the polymerization of lactide to produce PLA. The additional highly targeted energy associated with substitution of metal catalysts by organic ones were favourable to the reaction carried out in a first extruder. To purify the PLA from unreacted monomers and by-products, a second type of extruder was successfully used and the whole process enables to produce parts, even if the performance of organic catalysts was not yet enough to reach industrial scale standards. Figure 5 displays the InnoRex scheme process for PLA production.

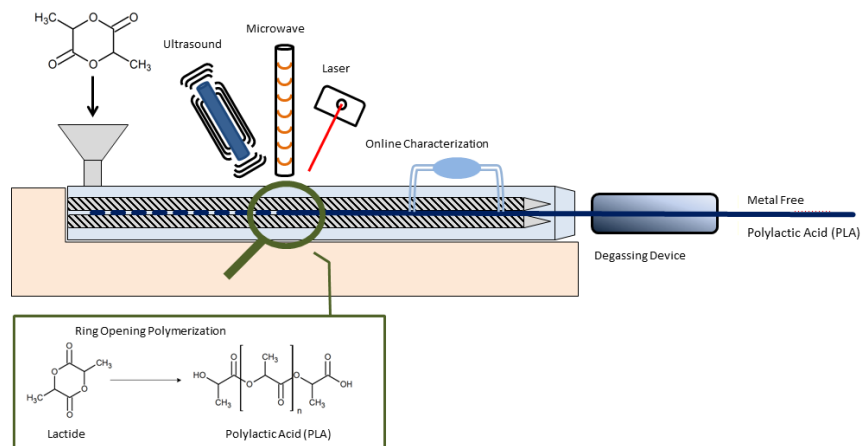

Figure 5: InnoREX scheme production process for PLA. Reprinted with permission from reference 13.

In order to optimize the process and increase PLA product quality, Ludovic software has been used to control thermo-mechanical properties evolution along the extruder.

Life Cycle analysis showed that the main driver for impact reductions is related to the ability of InnoREX process to make finished or semi-finished products in a one-step process, encompassing polymerization and e.g. injection moulding, without steps such as pelletizing, drying and melting of the PLA after polymerization.

Those first results have to be further confirmed by deeper and refined analyses once all the processes are upscaled at industrial level. In any case, Innorex technology seems to be relevant for reactive extrusion of bio-based polymers such as carbohydrates, polysaccharides that often need to be modified and or blended to adjust properties.

Modification of biodegradable polymers

Biodegradable polymers present some limits, which reduce their potential applications. In order to overcome these problems, many studies have been done, modifying biopolymers properties through reactive extrusion.

Raquez et al. carried out twin screw extrusion of 1,4-dioxan-2-one with 8 to 16 mol. % of ϵ -caprolactone (CL) to improve poly(1,4-dioxan-2-one) (PPDX) thermal stability. The thermal stability of poly(1,4-dioxan-2-one) is significantly

improved when adding small quantities of ϵ -caprolactone to 1,4-dioxan-2-one to form homopolymers and also blocky-like P(PDX-co-CL) copolymers, in which short PPDX and PCL sequences are randomly distributed. As soon as ϵ -caprolactone amount is not higher than 11 mol.%, the melting temperature of the copolymer remains close to the one of the poly(1,4-dioxan-2-one) homopolymer. In reactive extrusion, formation of copolymers requires reaction kinetics compatible with short reaction times and monomers with close chemical reactivities, in order to limit formation of homopolymers and amount of unreacted monomers [14]. All studies have been performed using aluminium tri-alkoxides as efficient initiator for synthesis of high molecular PPDX. Figure 6 displays a sensitive improvement in thermal stability of PPDX thanks to CL incorporation.

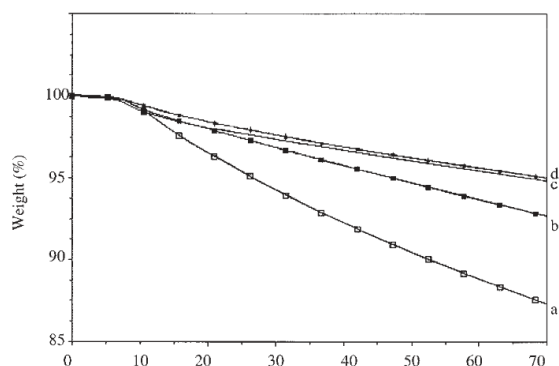
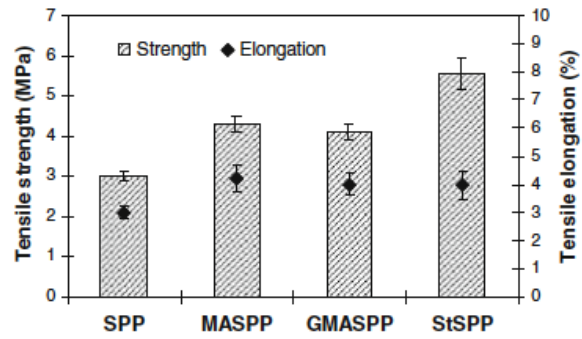
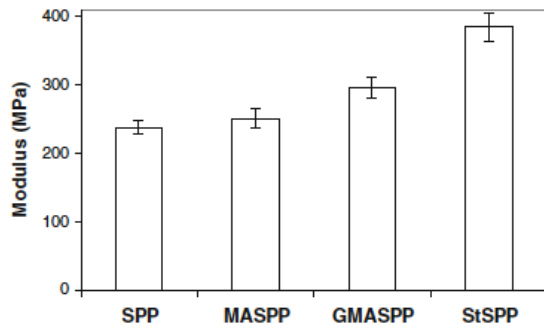

Figure 6: Time-dependence of weight loss for P(PPDX-co-CL) copolymers obtained by reactive extrusion with different final molar fractions in CL: $F_{CL} = 0.00$ (a), 0.11 (b), 0.16 (c) and 0.20 (d) ($T = 180^\circ\text{C}$ under an He flow). Reprinted with permission from reference 14, Copyright © 2005 Society of Plastics Engineers.

One of the main limits of natural polymers is their hydrophilicity, making them susceptible to moisture, influencing their dimensional stability and their mechanical properties. An example is soy proteins, which achieved great importance during last decades, despite its limit in strength and moisture absorption. Liu et al. [15] modified soy proteins plastic (SPP) with monomer of maleic anhydride (MA), glycidyl methacrylate (GMA) and styrene (St) using REX to give MASPP, GMASPP and StSPP. Chemical reactions and physical interactions between monomers' functional groups and soy proteins' side chains occurred during extrusion. Moreover, a reduction in denaturation temperature of soy proteins (except for styrene), an increase in glass transition temperature and an improvement in tensile properties were obtained (figure 7).



a



b

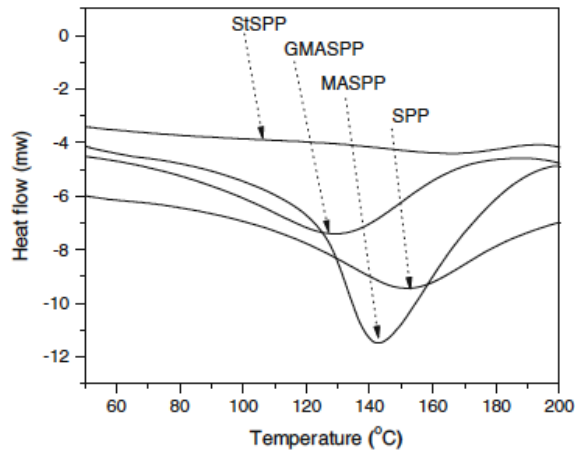

c

Figure 7: Effect of maleic anhydride (MA), glycidyl methacrylate (GMA) and styrene (St) on tensile strength (a), elongation at break (a), elastic modulus (b) and thermal properties (c) of modified SPP. Reprinted with permission from reference 15, Copyright © Springer Science+Business Media, LLC 2008.

Reactive extrusion can also be considered an interesting possibility to increase processability of hydrophilic polymers thanks to addition of chain extenders. These additives allow an improvement in processability of polymers that can be easily degraded during extrusion. Indeed, chain extenders can be used to increase thermal stability, melt strength and polymer blends compatibility. Considering well-known polyesters such as PLA or PBAT, their properties can be adjusted thanks to the addition of modified chains containing epoxy groups. The hydroxyl and carboxyl groups in aliphatic polyesters can react with epoxy groups of chain extenders, allowing covalent bond formation through the opening structure of epoxy groups [16]. For example, Al-Itry et al. [17] used a multifunctional epoxide, Joncryl (BASF), as a chain extender for both PLA and PBAT. They performed reactive extrusion in a co-rotating twin-screw extruder, under nitrogen flow, with a screw diameter of 16 mm, at 40 rpm for 3 min. Moreover, a special sealed and heated hopper has been used (figure 8).

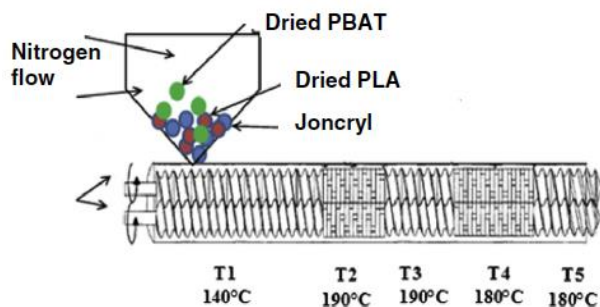

Figure 8: Scheme of extruder used for addition of multifunctional epoxides (Joncryl) to PLA or PBAT. Reprinted with permission from reference 17, Copyright © 2014 Elsevier Ltd.

The addition of chain extenders to PLA and PBAT resulted in a thermo-rheological complexity of these polyesters, explained by Al-Itry et al. through the formation of covalent bonds between Joncryl and PLA or PBAT. In fact, the failure of time-temperature superposition (TTS) theory suggested the thermo-rheological complexity behaviour of PLA and PBAT (figure 9).

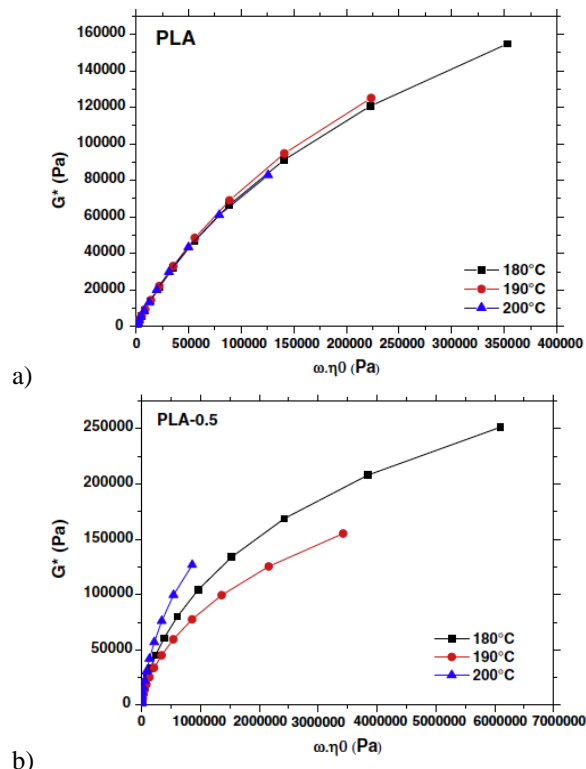

Figure 9: Complex modulus versus the product of zero-shear viscosity and frequency for: a) neat PLA (valid TTS) b) PLA-0.5 modified with 0.5 wt% Joncryl (not valid TTS). Reprinted with permission from reference 17, Copyright © 2014 Elsevier Ltd.

The influence of Joncryl seems to be more evident for higher percentages, suggesting the presence of branches on modified PLA and PBAT. Moreover, average molecular weight (M_w), measured through SEC in tetrahydrofuran, depends on Joncryl amount and residence time. A significant dependence of M_w with the amount of the multi-functionalized epoxy and reaction time was observed, as chain extension branching and degradation reactions are in competition [18-19].

Extrusion can also be used to perform treatments on natural polymers. In fact, the production of fuels from biomass, considering sustainability and environmental protection, is an interesting and challenging research subject. Biomasses are characterized by the presence of cellulose, hemicellulose and lignin, in an interconnected hierarchical structure. The structure breakage is needed, in order to potentially obtain sugars from which bio-fuels are produced.

A treatment is needed in order to eliminate lignin constituents, the natural barrier against microbial attack, increasing the possibility to convert cellulose and hemicellulose into mono-sugar. Alkali treatment seems to be an effective method to remove lignin, allowing lower sugar degradation compared to other chemical treatments [20]. Among studies about alkali treatments in extrusion process, Zhang et al. studied the effect of NaOH treatment of corn stover [21]. High shear extrusion and alkali treatments opened biomass hierarchical structure, increasing the specific surface area available for enzymatic attack. They obtained glucose and xylose sugar yields of 86.8% and 50.5% respectively, almost three times higher than untreated samples. Thanks to porosity analyses (figure 10), they suggested that alkali treatment allows a widespread meso and large porosity, significantly higher than for untreated samples, giving access points to enzyme digestion.

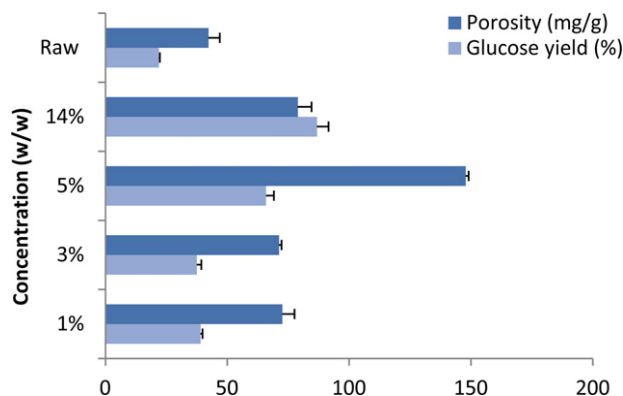

Figure 10: Correlation of porosity with glucose yields (raw refers to the untreated corn stover). Reprinted with permission from reference 21, Copyright © 2018 Elsevier B.V.

Subsequently, Vandenbossche et al. [22] analysed the possibility to use twin-screw extruder to perform treatments on different biomass products, such as dehydrated sweet corn (SC), sugarcane bagasse (SCB), sawdust of Eucalyptus grandis (SE), vineyard pruning (VP), blue agave bagasse (BAB) and oil palm empty fruit bunch (OPEFB). Thanks to this process (figure 11), they obtained the deconstruction of ligno-cellulosic products through alkali thermo-mechano-chemical pre-treatment, neutralization, extraction-separation and bioextrusion (step in which enzymes are introduced in the extruder).

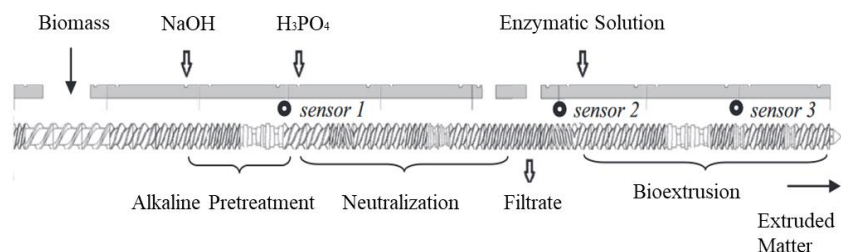

Figure 11: Scheme of continuous process to deconstruct lignocellulosic plant materials through alkaline pretreatment and bioextrusion. Reprinted with permission from reference 22, Copyright © © 2016 Elsevier Ltd.

Their motivation for selecting extrusion process was the possibility of using high solid concentrations, high shear, rapid heat transfer, effective and rapid mixing. Of course, optimized parameters have to be selected, for both treatments and bioextrusion, depending on biomass source. An example of different alkaline pretreatment conditions (with NaOH) and bioextrusion parameters is reported, derived from another work [23], in table 2.

Table 2: Operating conditions for alkali pretreatment and bioextrusion of different biomass sources.

DM: Dry Matter, SC: Sweet Corn, BS: Barley straw, BAB: Blue Agave Bagasse, OPEFB: Oil Palm Empty Fruit Bunch, L/S: liquid/solid ratio.
Reprinted with permission from reference 23, Copyright © 2014 The Authors. Published by Elsevier B.V.

Operating conditions	SC	BS	BAB	OPEFB
Alkaline pretreatment				
S ₅ (rpm)	110	150	85	200
T (°C)	100	68	75	98
NaOH/DM (%)	8.5	7.5	8.6	12.6
L/S	8	12	3.2	8.2
Bioextrusion				
S ₅ (rpm)	250	150	85	200
T (°C)	50	50	50	40
Enzyme cocktails	A	N ₁	N ₂	A
Enzyme/DM (%)	2.5	2.5	2	11.0
L/S	3.1	4	4.35	3.1

Bio and oil-based polymers blends

Reactive extrusion is also effective in order to increase the compatibility between bio-derived and oil-based polymers that are often immiscible.

Quintana et al. [24] worked on biodegradable blends of cellulose acetate (CA) with two water soluble polymers; polyvinyl alcohol (PVOH) and the bio-based hydroxyethyl cellulose (HEC). Like CA, HEC is valuable both biodegradable and bio-sourced. For that purpose, plasticization of CA and PVOH was carried out by using melt extrusion with triacetin and glycerol, respectively. A two-step method began with a plasticization of HEC by water, and then a melt processing. Plasticized PVOH-based blends proved to exhibit better processability and properties. The prepared blends were characterized in terms of morphology and thermo-mechanical properties. The quality of the blend interface was enhanced by reactive compatibilization using maleic anhydride grafted polylactide (MAgPLA). An original procedure was carried out using two extruders associated in a T configuration (figure 12) to prepare different plasticized CA-PVOH blends compositions. This advantageous set up allows for in situ plasticization of CA, which significantly reduces its thermo-oxidative degradation. The water-response of these blends was evaluated to settle on their potential as new water-dispersive biodegradable materials.

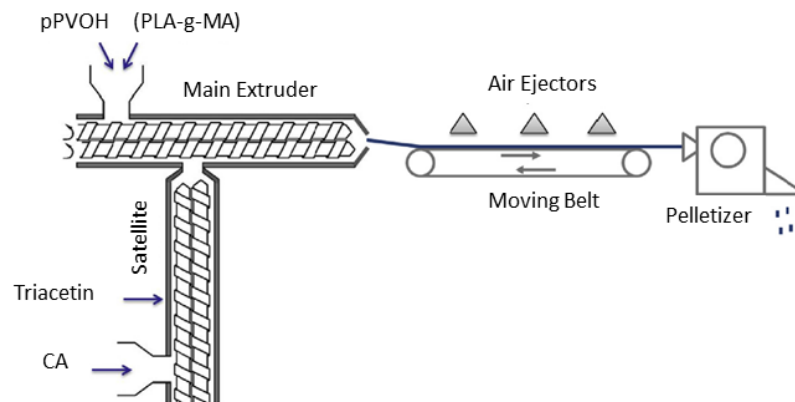

Figure 12: Original T-configuration in extruder setup for plasticized CA/PVOH blends production with on-line CA plasticization and addition of PLA-g-MA as reactive compatibilizer. Reprinted with permission from reference 24, Copyright © 2016 Elsevier Ltd.

Gutiérrez and Alvarez [25] produced eco-friendly films based on blends of a starch-based product, thermoplastic plantain flour (TPPF), poly(ϵ -caprolactone)

(PCL), and glycerol (plasticizer), through reactive extrusion. A twin-screw extruder has been adopted to produce the blends, using zirconium octanoate ($Zr(Oct)_4$) as catalyst (CAT). In particular, process setup is composed of two feed zones (one in the first heating step and one in the third heating step) and mix heating zones with 50/70/90/100/100/100°C temperature profile. Attenuated total reflectance fourier transform infrared spectroscopy (ATR/FTIR) displays the reactive extrusion effectiveness of thermoplastic plantain flour TPPS/PCL blends, obtaining compatibilization through $Zr(Oct)_4$ catalyst. Typical OH peak displays a decreasing intensity with catalyst and PCL addition, suggesting reduced hydrophilicity because of possible crosslinking formation between plantain flour and PCL (figure 13).

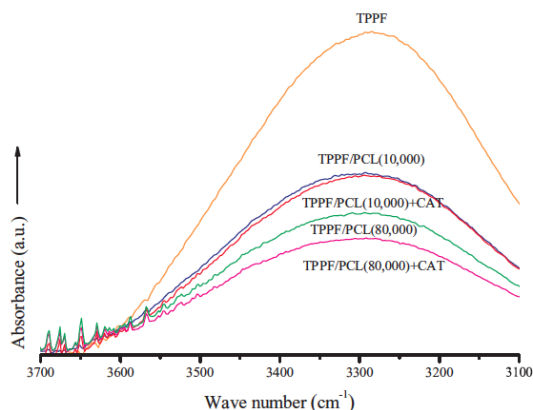

Figure 13: ATR/FTIR spectra in the absorption range of OH stretching for plantain flour (TPPF), plantain flour with PCL (Mw of 10,000 g/mol) (TPPF/PCL(10,000)), plantain flour with PCL (Mw of 10,000 g/mol) and catalyst (TPPF/PCL(10,000)+CAT), plantain flour with PCL (Mw of 80,000 g/mol) (TPPF/PCL(80,000)), plantain flour with PCL (Mw of 80,000 g/mol) and catalyst (TPPF/PCL(80,000)+CAT). Reprinted with permission from reference 25, Copyright © 2017 Elsevier Ltd.

Unlike oil-based polymers, bio based are often recent materials with about no studies devoted to their recycling.

Recycling of oil-based polymers by using reactive extrusion

Oil based polymers are extensively used in transportation industry where they contribute to lightering, packaging... Even if their recycling rate is much lower than the one of steel, they can be recycled for high value added parts, such as bumpers as described below.

Material recovery of polyolefins for production of bumpers

Polyolefins are among the most used materials in our everyday lives. As a consequence, they require an appropriate recycling process in order to both obtain optimal properties of post-consumer products and adequate disposal. REX seems to be an efficient production technique, able to produce recycled products useful in industrial applications. Moreover, because of legislation such as the one for European End of Life Vehicles, recycling of polymers for high value applications is necessary. Iso function recycling of polypropylene based car bumpers has been successfully carried out by laboratory Ingénierie des Matériaux Polymères (IMP) and Plastic Omnium Company [26-28]. The method suggests innovative treatment for materials, mainly composed of PP and PE mixtures, derived from recovery and grinding of car bumpers. Moreover, the idea of the method can be extended to all polypropylene sources contaminated with polyethylene. Figure 14 displays a front view of a car bumper.

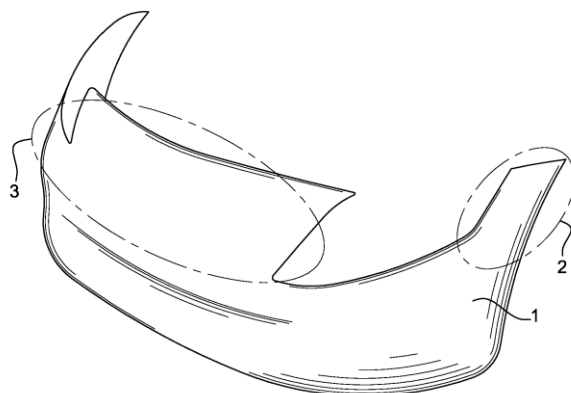

Figure 14: Perspective front view of car bumper (1), Aspect zones of car bumper (2 and 3) [28].

Recycling of post-consumer car bumpers into car bumpers produced with recycled materials requires maintaining three main characteristics:

- a) Mechanical Properties: PP coming from recycling is mixed with PE, as their close densities do not permit to separate them by flottation. Indeed, it is quite usual that recycled PP contain up to 20% PE, that can lead to a spectacular decrease of impact properties. Thus, it is necessary to compatibilize those blends in order to increase/restore their mechanical properties.
- b) Melt processing/Rheology. Due to both its complex geometry and important dimensions, it is essential to have low viscosity formulations to facilitate injection molding.
- c) Ability to be painted Class A.

Formulations can be performed in horizontal extrusion, as the one proposed in figure 15.

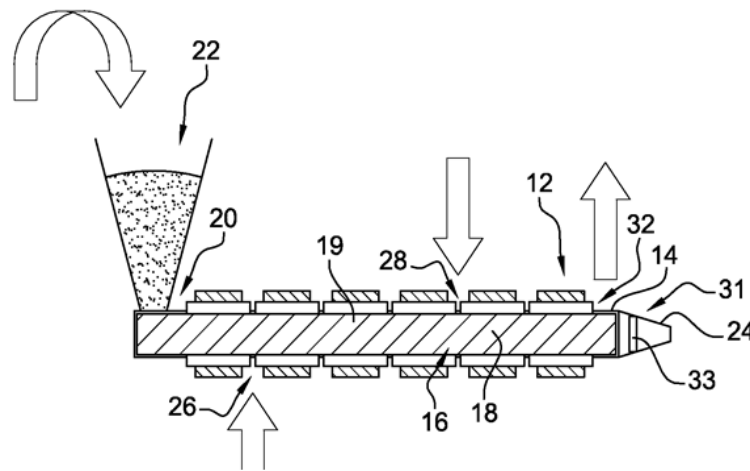

Figure 15: Equipment used to perform reactive extrusion. Legend of the figure: 12) Stator of the extruder, 14) Scabbard of the extruder, 16 and 18) Rotor of the extruder composed of mono or twin endless screw, 19) Space between scabbard and rotor allowing material processing, 20) Principal compounds introduction, 22) Hopper for grinding materials and additives feeding, 24) Extrusion head, 26) Intermediate feeding zone for additives introduction, 28) Intermediate feeding zone for pressurized water, 31) Exit of the extruder, 32) Exit zone for water and pollutants evacuation, 33) Extrusion supply chain [28].

Post-consumed PP based materials are grinded to obtain suitable dimensions for extrusion; they are then separated, washed and dried. Grinded materials are introduced in the extruder to mix and melt them. Peroxide, antioxidant and reactive molecules are introduced, to compatibilized grinded materials and obtain optimal properties through reactive extrusion.

In case of PP recycling often mixed with ethylene based polymers and copolymers, it has to be noted that whereas PP has a tendency to undergo radical β -scissions, ethylene based polymers or copolymers tend to graft or reticulate. To adjust viscosity of recycled polymers, reactive extrusion of polymers with peroxides is a good way to cut PP chains and there are many publications describing the decomposition kinetic of peroxides such as dicumyl peroxide (DCP), 2,5-dimethyl-2,5-di(tert-butyl peroxy)hexane (DHBP) [29-32]. In this context, the direct introduction of peroxides in PP/ethylene based polymers and copolymers would degrade mechanical properties. Thus, it is indispensable to feed first rich in propylene with an oxidizing agent and, later along the screw, anti-oxidizing and rich in ethylene materials. Thanks to sequencing of reactions, it is possible to fluidify the blends while maintaining good mechanical properties. Small hydrophilic molecules are extracted thanks to water addition in the extruder (figure 15.28), and de-volatilization at the end of the screw (figure 15.32).

Perspective of “universal recycling” by using irradiation

Polypropylene (PP) and polyethylene (PE) are extensively used in industrial fields such as automotive or electrical and electronics industries. Hence, making new high value added materials from post-consumer PP and PE wastes is a challenge as most of the usual sorting technologies are only able to recuperate them as mixes. With the aim of improving properties of PP/PE blends, high value added PP/PE blends were achieved after reaction of radicals produced by γ -irradiation [33, 34]. γ -irradiation was carried out under air atmosphere, at room temperature and at solid state, with an irradiation dose rate of 2kGy h^{-1} and a whole dose of 25 kGy [33, 34].

The generation of radicals is extensively obtained with peroxides but the use of γ -irradiation allows to modify materials in solid state, avoiding, at the same time, formation of secondary products or residual reagents associated with peroxide reactions. This technology is based on the formation of free radicals associated with covalent bonds cleavage, occasioning oxidation, cross-linking and chain scission phenomena. Figure 16 [34] displays the traditional processing for polyolefins blends (process A) as well as the addition of γ -irradiation for process B. Process A is composed of extrusion followed by injection moulding. Process

B is characterized by three stages: extrusion process, γ -irradiation and then injection moulding.

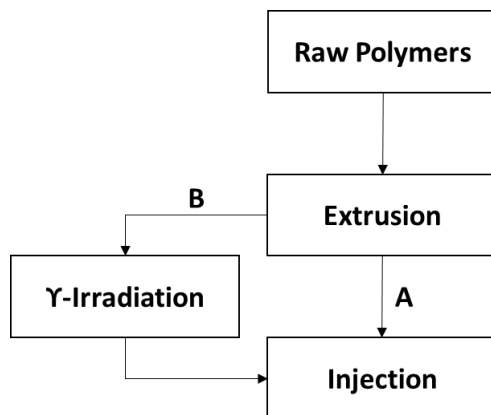

Figure 16: Processing steps of processes A (reference) and B. Adapted with permission from reference 34, Copyright © 2015 Elsevier Ltd.

New interactions between PP and PE (figure 17) are displayed thanks to process B, in addition to traditional weak interactions between PE and PP macromolecules already present in process A.

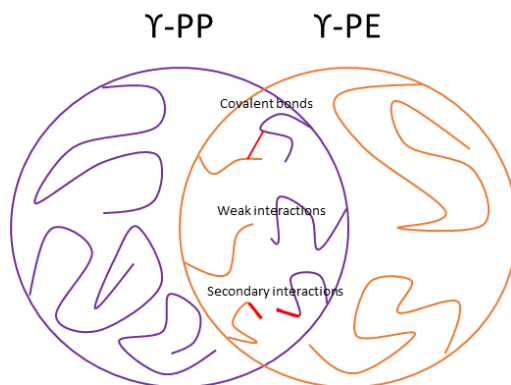

Figure 17: Possible reaction and interactions likely to occur after γ -irradiation: covalent bonds, weak interactions between PP and PE and secondary interactions. Adapted with permission from reference 34, Copyright © 2015 Elsevier Ltd.

Mechanical properties, such as Charpy impact and elongation at break, of PP/PE blends was clearly improved for the γ -irradiated polymer processed at 1 200rpm (figure 18).

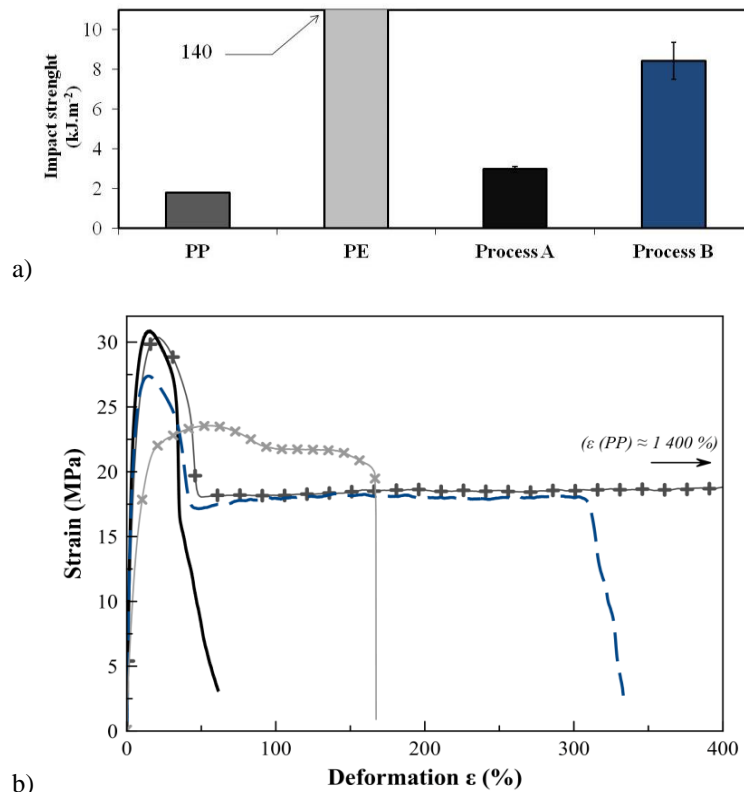

Figure 18: a) Charpy impact strength obtained at 20°C and b) tensile behaviour at room temperature for neat PP (+), neat PE (x), Process A (—), Process B (---) extruded at 1200 rpm. Reprinted with permission from reference 34, Copyright © 2015 Elsevier Ltd.

The increased mechanical properties suggest an improved compatibility between polypropylene and polyethylene thanks to reactive extrusion, in agreement with other results obtained in the study.

As a conclusion, it is found that introduction of γ -irradiation in a chosen process is relevant for the enhancement of the properties of polyolefin blends. Such a reactive processing can be used to develop an efficient recycling of polyolefins

blends and opens perspectives of universal recycling and blending by creation of copolymers at the interface of the polymer blends to be recycled. As another example, γ -Irradiation can be useful for blending polycarbonate and starch [35]. Addition of 10% starch in polycarbonate induced higher increase in both Young's modulus and elongation at break when irradiating the blend with 50 kGy than without irradiation. When irradiating a blend made of 90% PC and 10% Starch with 50 kGy, modulus reaches about 1,100 Mpa and elongation at break about 110%, to be respectively compared to about 850 Mpa and 60% for non irradiated neat PC. UV-irradiation is an easier to handle technology than γ -irradiation and has been used for the melt blending of polystyrene and polycarbonate [36] as well as for the depolymerisation of PP [37]. Those few examples illustrate that combination of extrusion and irradiation is relevant to decrease use of chemicals for greener processes [38].

A lot of studies have been carried out for facilitating polymer recycling and reactive extrusion can provide suitable solutions. For example, PET can undergo coupling reactions in extruder to maintain chain lengths. Reactive extrusion can also be used to depolymerize PET by cutting the chains into oligomers [39] to be used in future chemical syntheses.

Conclusion

Reactive extrusion, that is a continuous fast process, solvent free and can substitute chemicals by irradiations concentrates lots of benefits.

The few examples given in this chapter illustrate that reactive extrusion contributes not only to the development of eco-friendly materials but also to their green recycling for a new life.

As a consequence, reactive extrusion can be considered as a relevant technology for the challenges of eco-friendly circular economy.

References

1. Formela, K.; Zedler, L.; Hejna, A.; Tercjak, A. *Polym. Lett.* **2017**, 12, 24-57.
2. Giles, H.F.; Wagner, J.R.; Mount, E. M. *Extrusion: the definitive processing guide and handbook*, William Andrew: Norwich, NY, 2005, pp 193-198.
3. Vergnes, B; Berzin, F. *Chimie.* **2006**, vol 9, 1409-1418.
4. Touhtouh, S.; Becquart, F.; Taha, M. *J. Appl. Polym. Sci.* **2011**, vol 123 (5), 3145-3153.
5. Goma-Bilongo, T., Couenne, F.; Jallut, C.; Le Gorrec, Y; Di Martino, A. *J. Ind. Eng. Chem. Res.* **2012**, vol 51 (35), 11381-11388.
6. Fogler, H.S. *Elements of Chemical Reaction Engineering, 4th Ed*, Prentice Hall: Upper Saddle River, NJ, 2006, pp 865-944.
7. Fel, E.; Massardier, V.; Melis, F.; Vergnes, B.; Cassagnau, P. *Int. Poly. Proc.* 2014, 29, 71-80.
8. Becquart, F.; Chalamet, Y.; Chen, J.; Zhao, Y.; Taha, M, *Macrom. Mat. Eng.* **2009**, 291, 543-650.
9. Banu, I.; Puaux, J.P.; Bozga, G.; Nagy, I, *Macromol. Symp.* **2010**, 289, 108-118.
10. Berzin, F.; Tara, A.; Tighzert, L.; Vergnes, B. *Poly. Eng. Sci.* **2010**, 1758-1766.
11. Quitadamo, A.; Massardier, V.; Valente, M. In *Introduction to Renewable Biomaterials: First Principle and Concepts*; A.S. Ayoub; L.A. Lucia; Wiley: Hoboken, NJ, 2017, pp 239-268.
12. Bonnet, F.; Stoffelbach, F.; Fontaine, G.; Bourbigot, S, *RSC Adv.* **2015**, 5, 31303-31310.
13. www.innorex.eu, Innorex About the Project, last acces April 25th, 2018. European Union Seventh Framework Programme (FP7/2007-2013) under grant agreement n° 309802.
14. Raquez, J.M.; Degee, P.; Dubois, P.; Balakrishnan, S.; Narayan, R, *Poly. Eng. Sci.* **2005**, 45, 622-629.
15. Liu, W.; Mohanty, A.K.; Askeland, P.; Drzal, L.T.; Misra, M., *J. Poly. Environ.* **2008**, 16, 177-182.
16. Arruda, L. C.; Magaton, M.; Bretas, R. E., S.; Ueki, M. M., *Poly. Test.* **2015**, 43, 27-37.
17. Al-Itry, R.; Lamnawar, K.; Maazouz, A, *Eur. Polym. J.* **2014**, 58, 90-102.
18. Lehermeier, H.J.; Dorgan, J.R., *Polym. Eng. Sci.* **2001**, 41, 2172-2184.
19. Munari, A.; Pezzin, G.; Pilati, F.; Manaresi, P., *Rheol. Acta* **1989**, 28, 25-29.
20. Mosier, N.; Wyman, C.; Dale, B.; Elander, R.; Lee, Y. Y.; Holtzapple, M.; Ladisch, M., *Biores. Tech.* **2005**, 96, 673-686.

21. Zhang, S.; Keshwani, D. R.; Xu, Y.; Hanna, M.A., *Ind. Crop Prod.* **2012**, 37, 352-357.
22. Vandenbossche, V.; Brault, J.; Hernandez-Melendez, O.; Evon, P.; Barzana, E.; Vilarem, G.; Rigal, L., *Biores. Tech.* **2016**, 211, 146-153.
23. Vandenbossche, V.; Brault, J.; Vilarem, G.; Hernandez-Melendez, O.; Vivaldo-Lima, E.; Hernandez-Luna, M.; Barzana, E.; Duque, A.; Manzanares, P.; Ballesteros, M.; Mata, J.; Castellon, E.; Rigal, L., *Ind. Crop Prod.* **2014**, 55, 258-266.
24. Quintana, R.; Persenaire, O.; Lemmouchi, Y.; Bonnaud, L.; Dubois, P., *Poly. Deg. St.* **2016**, 126, 31-38.
25. Gutiérrez, T.J.; Alvarez, V.A., *Carb. Poly.* **2017**, 178, 260-269.
26. Viot, F.; Guillet, J.; Cassagnau, P.; Massardier-Nageotte, V. Patent FR20080058167, 2010.
27. Cassagnau, P. ; Mani, S. ; Massardier, V. ; Viot, F. Patent FR 2984894 (A1). 2014
28. Cassagnau, P.; Massardier, V.; Viot, F. Patent FR 2997403 (A1), 2016
29. Josse, C.; Massardier, V.; Khrouz, L.; Cassagnau, P.; Viot, F., *Poly. Eng. Sci* **2016**, 56, 418-426.
30. Azizi, H.; Ghasemi, I.; Karrabi, M., *Poly. Test.* **2008**, 27, 548-554.
31. Berzin, F.; Vergnes, B.; Delamare, L., *J. App. Poly. Sci.* **2001**, 80, 1243-1252.
32. Berzin, F.; Vergnes, B.; Canevarolo, S.V.; Machado, V.; Covas, J.A., *J. Appl. Polym. Sci.* **2006**, 99, 2082-2090.
33. Fel, E.; Khrouz, L.; Massardier, V.; Bonneviot, L., *Polymer* **2015**, 77, 278-288.
34. Fel, E.; Khrouz, L.; Massardier, V.; Cassagnau, P.; Bonneviot, L., *Polymer* **2016**, 82, 217-227.
35. Vignon A., Ayoub A., Massardier V., *J. Appl. Polym. Sci.* **2013** vol 127, 5, 4168-4176.
36. Ayoub A., Massardier-Nageotte V. The effect of UV-irradiation and molten medium on the mechanical and thermal properties of polystyrene-polycarbonate blends, *J. App. Poly. Sci.*, **2012**, 124, 1096-1105
37. Cao X. W., He G-J, Yin X-C, Peng X-F, *Poly. Deg. St.* **2013**, 98, 276-280.
38. Ayoub A., Venditti R., Pawlak J.J., Massardier V., *BioResour.* **2013**, 8, 3-5.
39. Cassagnau Ph., Michel A., Argalon Dannoux M., Robin J.J., FR 2 825 701, **2002**