

THE FUSION OF PLANE AND SOLID GEOMETRY IN THE TEACHING OF GEOMETRY:

Textbooks, Aims, Discussions.

Marta MENGHINI

Dipartimento di Matematica

Sapienza, Università di Roma, Piazzale Aldo Moro 5, 00185 Italy

marta.menghini@uniroma1.it

ABSTRACT

The idea of the fusion of plane and solid geometry originated from projective and descriptive geometry, which worked with projections in space and sections. Different authors of textbooks (starting from Bretschneider in 1844 to Méray in 1874/1903; de Paolis in 1884; Lazzeri & Bassani in 1891, also translated into German by Treutlein in 1911) adopted this idea, mixing plane and solid considerations. For instance, the chapter on the properties of incidence also referred to the mutual position of a plane and a straight line, while homothety was defined in space and then on the plane. Pupils were supposed to have a better intuition of spatial relations when passing from space to plane, and to reason by analogy. Moreover, proofs could be presented of plane theorems using projections in space of simple known configurations. In the textbook of Lazzeri and Bassani we can see that one of the aims of the authors is to prove plane theorems with the help of considerations in space that allow to avoid part of the congruence axioms and the theory of proportions. This is not a novelty within history of mathematics, the development of conic sections is linked to this point, and Monge, too, used it in 1799. The question was also considered at the ICMI Congress of 1911—within the more general theme of the fusion of different branches of mathematics—by giving examples of successful textbooks (Fehr 1911; Barbin & Menghini 2013). This paper will discuss the methodological question of the fusion of plane and solid geometry bringing examples from different textbooks, and presenting some of the discussions on the subject, with particular reference to Italy, where there was even talk of a *fusionist school* (Borgato 2006 and 2016).

1. Introduction

This paper concerns the *fusion* of plane and solid geometry in the teaching of mathematics, that is the simultaneous use of plane and solid considerations when presenting and proving geometric properties at school. In Italy, at the turn of the 19th and 20th century this methodological question was deeply debated and there was even talk of a “fusionist school” (Borgato 2006 and 2016).

We will consider the history of mathematics education starting from about two centuries ago, in the era of Gaspard Monge. However, the method of “fusion” does not belong only to the history of mathematics education but to history of mathematics in general. Indeed, it was used already by Apollonius to determine plane properties of the conic sections.

In 1911 the first plenary meeting of the International Commission on the Teaching of Mathematics (IMUK / ICMI / CIEM) was held in Milan (Italy). On this occasion a broader concept of fusion was discussed. The report of the discussion (Fehr 1911) was published in the Journal *l'Enseignement Mathématique*, which was at that time the official organ of the Commission. The report, based on an overview presented by Charles Bioche, refers to the teaching in various countries, and to the way in which they realize the different types of “fusion”: geometry and arithmetic, plane geometry and trigonometry, plane and solid geometry (which is of interest for us), solid and descriptive geometry (which, as we will see, has also some interest for our question).

As to the *fusion of plane and solid geometry*, we read in the report (p. 469) that “the *fusionists* do not wait to have finished the treatment of all plane geometry before starting with spatial considerations”¹, and that “generally the two teachings are separated, excluding the entrance classes, because of the programmes. But “notable works appeared on geometric *fusionism*”. The mentioned textbooks are those written by the German Anton Bretschneider (1844), the French Charles Méray (1874/1903), and the Italians Giulio Lazzeri & Anselmo Bassani (1891). The report does not say very much about the educational pros or cons of the different of proposals.

Concerning the fusion of *solid geometry* and *descriptive geometry*, the report notes that these teachings are generally separated, and often not given by the same teacher (the report refers mainly to *Realschulen* in German speaking countries).

In the same number of the Journal we find a book review (Book review 1911) of Lazzeri & Bassani’s *Elemente der Geometrie*, the German edition of the textbook, translated by Peter Treutlein and published by Teubner.

The review underlines that the idea of the fusion of plane and solid geometry is not new, since this methodology had already been presented in the Journal by “one of the main founders, Ch. Meray”.

The first edition of his [Méray’s] book dates back to 1874, while the first Italian work – established on different bases – was published by De Paolis in 1884. The present work broadly follows the order traced by De Paolis (Book review 1911, p. 429).

The review lists the contents of the book but does not describe the methodology used. Rather, it seems aimed at proving the priority of Méray (who died in 1911) with respect to “fusionism”.

But the important sentence in the review is “established on different bases”. What does it mean?

We do not know what the author of the review was meaning, but surely we can distinguish between two kinds of approach:

- a methodological/educational approach based on a “new order” of the content allowing a “neighbourhood” of analogous properties in plane and space (mainly the one of Bretschneider, but also of Méray and de Paolis, with some exceptions). We describe this approach in section 3.

- a mathematical/foundational approach based on the proof of plane theorems by means of space configurations (mainly the one of Lazzeri & Bassani).

This second approach is shown in the next chapter.

2. Proofs by means of space configurations

The link between plane and space dates back to the beginning of the history of conic sections, which are defined as plane sections of a solid. It is not only a question of definitions: their properties can be proved looking at their position with respect to the cone.

2. 1 Apollonius

One of the major works about conic sections is *The Conics* by Apollonius of Perga (3rd - 2nd cent. B.C.). In Book 1, Proposition XI (ver Eecke 1963, p.22) we find a sort of “equation of the parabola”.

¹ All the translations are by the author.

The cone is defined by Apollonius as the set of straight lines that join a point A (the vertex) to the points of a circumference. It is therefore an *oblique circular double cone*. Fig. 1 (taken from Ver Eecke 1963, p.22) represents the case in which the cone's section yields a parabola.

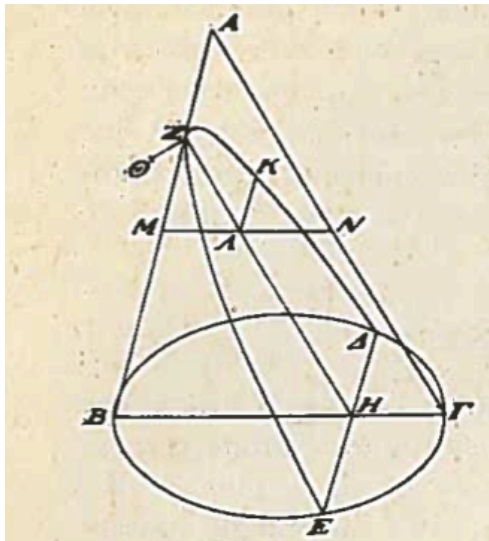

Figure 1

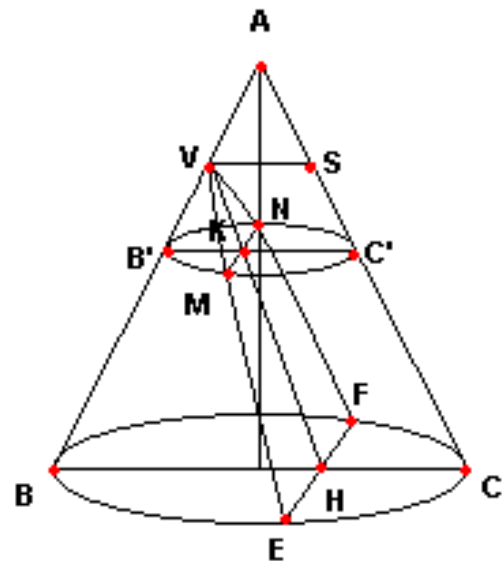

Figure 2

To slightly simplify the proof, let us consider a *right circular cone*, where BC is the diameter of the base circumference. In Fig. 2 we consider

$$EF \perp BC; H = EF \cap BC; VH \parallel AC.$$

The plane EFV is therefore parallel to a generatrix of the cone and cuts it in a *parabola*.

Now we chose any circumference whose diameter $B'C'$ is parallel to BC , and take MN on the circumference and on EFV so that $MN \parallel EF$ and $K = MN \cap B'C'$

Euclid's "geometric mean theorem" holds for triangle $B'C'M$:

$$MK^2 = B'K \cdot KC'$$

What does it mean to find the equation of the parabola? We need a relation between two mutually perpendicular segments, in this case MK and KV , $MK \perp KV$, which correspond to our x and y .

To find this relation Apollonius considers the similarities between $VB'K$ and ABC , and between AVS and ABC , obtaining

$$\begin{aligned} \frac{B'K}{B'V} &= \frac{BC}{BA} \rightarrow \overline{B'K} = \overline{B'V} \cdot \frac{BC}{BA} = \overline{KV} \cdot \frac{BC}{BA} \\ \frac{VS}{VA} &= \frac{BC}{BA} \rightarrow \overline{VS} = \overline{VA} \cdot \frac{BC}{BA} = \overline{KC'} \end{aligned}$$

In the previous formulas we replaced $B'V$ by KV (two sides of an isosceles triangle, note that this is the only point in which we use the fact that the cone is a right cone) and VS by KC' (two opposite sides of a parallelogram). Substituting in the formula for the geometric mean theorem we obtain

$$MK^2 = \overline{KV} \cdot \overline{VA} \cdot \left(\frac{BC}{BA}\right)^2 \rightarrow x^2 = p \cdot y$$

In the previous equality we have considered that MK and KV are variables which depend on the changeable circumference whose diameter is $B'C'$. All the rest is constant and depends on the cone and the point in which the plane of the parabola cuts the cone.

The original proof is of course more difficult because Apollonius uses only proportions between geometric objects (for instance our p of the last equation corresponds to a segment –named Θ in Fig. 1– with certain properties). Apollonius finds analogous relations for the ellipse and the hyperbola, but what is interesting for us is that starting from a space definition and considering (always in space) elementary geometric properties we find a relation between two segments in the plane.

2.2 Gaspard Monge

In 1799 the *Géométrie Descriptive* by Gaspard Monge was published. The book is “pour l’usage des élèves de la première École Normale” and is devoted to future teachers.

Descriptive geometry deals with the representation of three-dimensional objects through drawings in two dimensions by projection and section (its *first aim*). In a certain sense it can be seen as a generalization of conic sections: the latter rise from a projection of a circle from a point and a successive section with a plane. Descriptive geometry deals with parallel or central projections of different geometric objects, and plane sections. The *second aim* of descriptive geometry is, according to Monge, “to research truth in geometry”. The exactness of drawings and the research for truth render the content important for all the students of the French educational system (Barbin, to appear). So we have again to do with the history of mathematics education.

The first part of the book deals with the method of projections and shows how to determine the position of a point in space. The second part concerns tangent planes and normals to surfaces. It requires the capacity of seeing relations in the space. Here we find very interesting proofs of plane theorems made with the help of space considerations.

Let’s for instance consider one of the properties proved by Monge (1847, p. II, n. 39, see Fig. 3). Our prove follows the notation of Fig. 4.

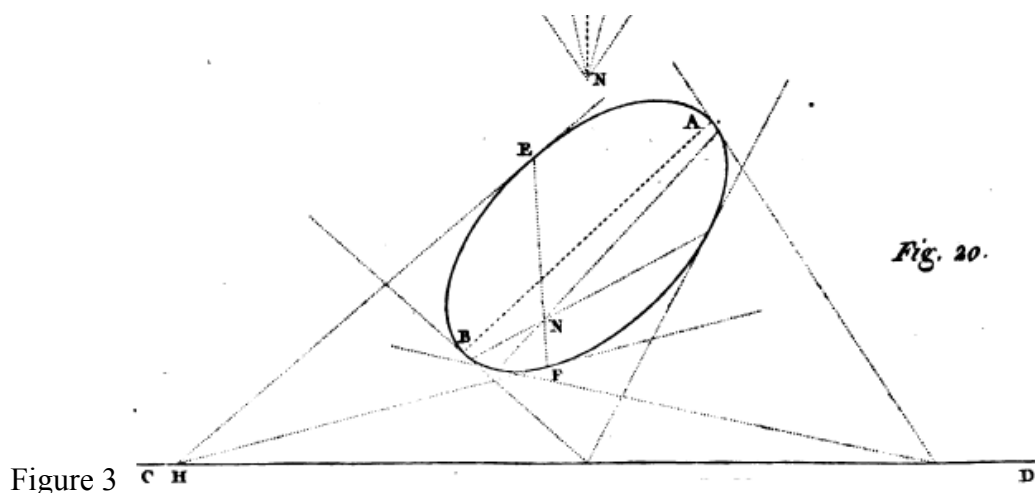

Let's take a line and points on it Q, Q' , etc.. From each point Q, Q', \dots we draw tangents to a given conic section (e.g. an *ellipse* E). For each pair of tangents, we draw line r cutting the ellipse in two points R and R' . All the lines constructed in the same way pass through a same point P .

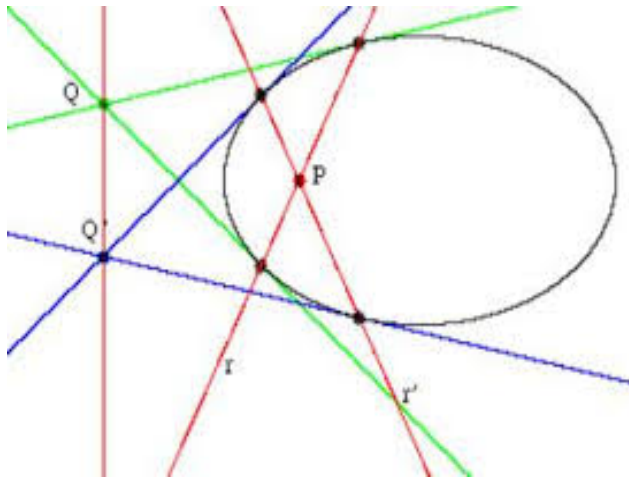

Figure 4

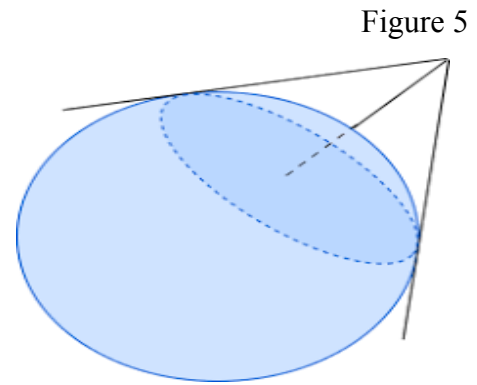

Figure 5

Proof: let the ellipse rotate about one of its axes, thus obtaining an ellipsoid. A cone with vertex Q touches the surface in an ellipse C (Fig. 5).

If the two tangent planes through the line QQ' touch the ellipsoid in two points P_1, P_2 (see Fig. 6, taken from <https://commons.wikimedia.org>, where P and P_1 are exchanged), the ellipse C passes through P_1 and P_2 .

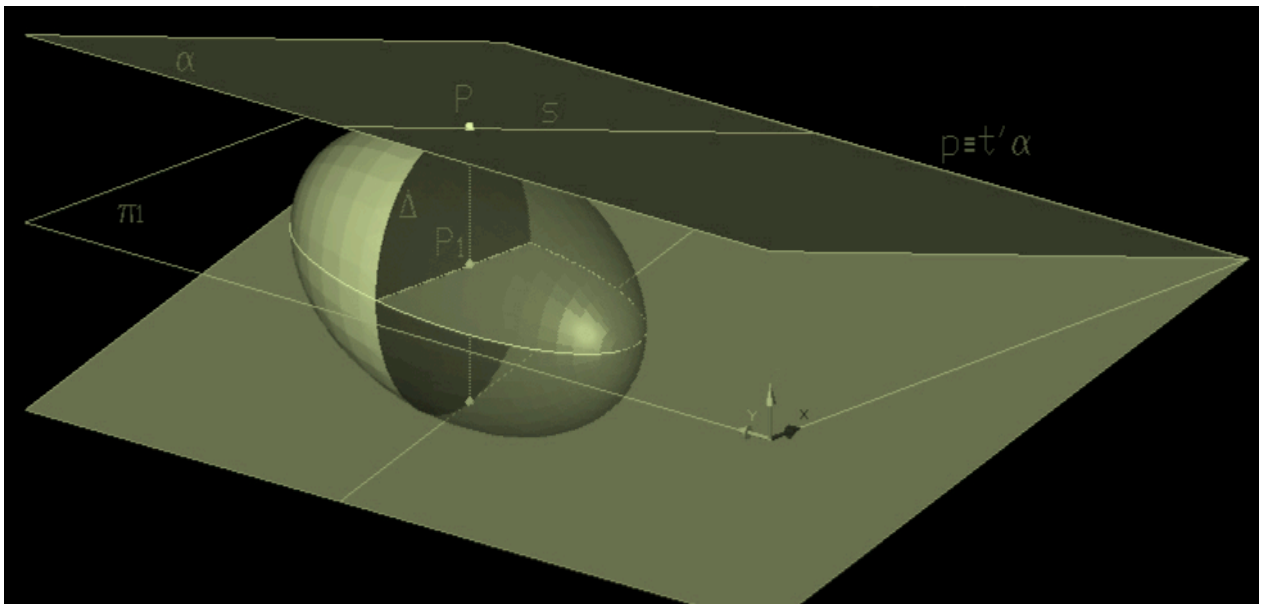

Figure 6

The plane of C is \perp to π_1 (the plane containing the original ellipse E), and $C \cap E = R, R'$ (note that C is any circumference rotating about the line P_1P_2 , while the dark

circumference indicated with Δ in figure 6 is a limit case of C when Q is the point at infinity of the line common to the two planes) The intersection $P_1P_2 \cap RR'$ yields the point P . This happens for any point Q , so the theorem is proven.

2.3 Pierre Germinal Dandelin

In a paper of 1822 Pierre Germinal Dandelin, a former student of the *Ecole Polytechnique*,

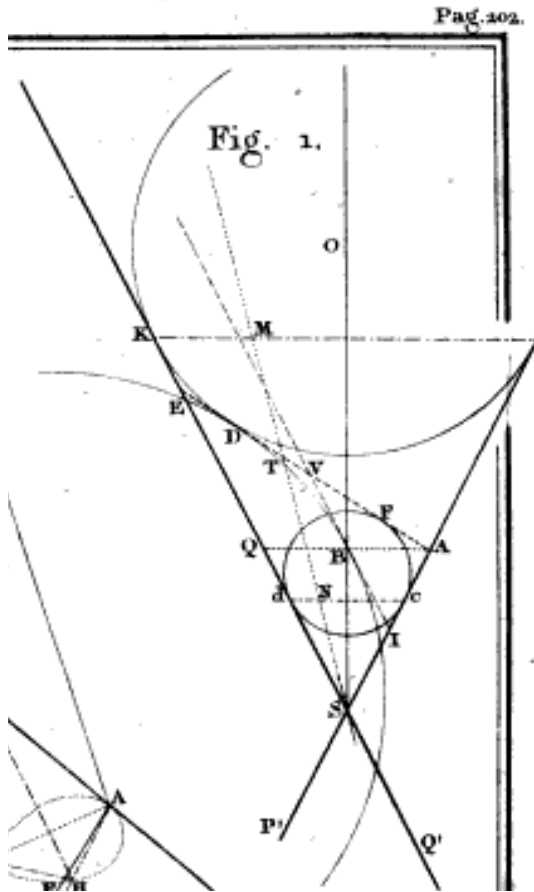

Figure 7

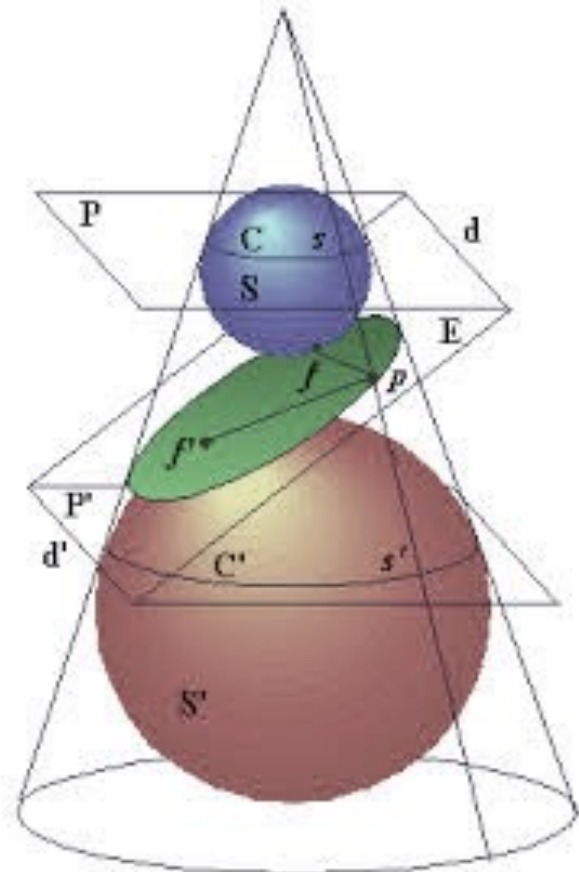

Figure 8

presents a well-known proof that links the definition of a conic as a section of a cone to its definition as a locus of points. We are in a period in which the development of descriptive geometry brings with it also a revival of synthetic geometry.

For the proof, Dandelin considers two spheres tangent to a cone and to the plane that yields a conic section (Fig. 7, from Dandelin 1822, p. 169). We will consider the case of an *ellipse*, following the notation of Fig. 8 (taken from <https://xavier.hubaut.info/coursmath/2de/belges.htm>):

A plane cuts a cone in an ellipse E . The sphere S touches the cone in a circumference C , and touches the plane containing E in f . The sphere S' touches the cone in a circumference C' and touches the plane containing E in f' . Take p on E . The generatrix through p touches S in s , and S' in s' . It holds

$$pf = ps; pf' = ps' \text{ (equal tangent segments to the spheres)}$$

$$\rightarrow pf + pf' = ps + ps' = ss'$$

The distance $ss' = \text{constant}$. We thus obtain that for any point p on E the sum of the distances $pf + pf'$ is constant. This is the definition of an *ellipse as locus of points*. As for the proof by Apollonius, we used elementary geometric properties in space to find a relation in the plane.

This proof can be found in some textbooks, but strangely I did not find it in books which present a *fusionist* approach, instead I found it in the part concerning *solid geometry* of books as Henrici & Treutlein (1891/1901) and Cateni & Fortini (1958).

3. A new order in the textbooks

3.1 Carl Anton Bretschneider

One of the first textbooks to present a new order allowing a better integration of plane and space considerations is the one by Carl Anton Bretschneider in 1844. The aim is clearly stated in the introduction:

Basing the synthetic part of my book on the division into geometry of position, of form, measure, and organic geometry, which is offered by the nature of this science, the separation of the matter into the two main sections of plane and solid geometry could not be allowed anymore [...] The pedagogical value cannot be denied (Bretschneider, 1844, p. VI).

Let's see in which way Bretschneider groups the various topics; in the following list of contents the chapters 1, 3, 4 of Book one concern plane geometry, the other concern geometry of space. In Book 2, the first five chapters are about plane geometry, the others about solid geometry.

Book 1. <i>Geometry of position</i> Ch. 1 the straight line Ch. 2 the plane Ch. 3 plane angles Ch. 4 parallelism in the plane Ch. 5 wedges [dihedral angles in the space] Ch. 6 Angles between lines and planes Ch. 7 parallelism in space	Book 2. <i>Geometry of form</i> Ch. 1 plane figures Ch. 2 plane triangles Ch. 3 quadrilaterals Ch. 4 circles Ch. 5 circumscribed and inscribed circles Ch. 6 solid angles Ch. 7 polyhedra in general Ch. 8 pyramids Ch. 9 prisms Ch. 10 the sphere
-----------------------------------------------------------------------------------------------------------------------------------------------------------------------------------------------------------------------------------------------------------------	----------------------------------------------------------------------------------------------------------------------------------------------------------------------------------------------------------------------------------------------------------------------------------

Book 3 concerns the *Geometry of measure* and also contains the theory of proportions and of similarity. The first 6 chapters are about plane measures, the 4 last chapters are about volumes and surfaces and lengths in the space.

The second part of the book is on *analytic geometry*, more precisely:

Book 4 and 5 are on plane goniometry and trigonometry,

Book 6 is on coordinates, and Ch. 5 considers *coordinates in space*.

Then we find five appendices, about geometric constructions in the plane; geometric loci in the plane, in particular conics; the method of *projections*; the area of a parabola and of an ellipse; the area of spherical triangles.

The Appendix 3 deserves a particular attention. It presents the method of *projections* (the “new geometry”) in plane and space and contains interesting propositions, including the proofs of *Apollonius* for parabola, ellipse and hyperbola. Other plane propositions, proved by Monge using 3D geometry, are proved here using the theory of polars in the plane.

So, we can see that in the textbook of Bretschneider there is still a separation between plane and solid considerations, but similar topics are – when possible - the one near the other. The only really “fusionist” argumentations are the proofs by Apollonius, which are presented using the proportions among similar triangles, as shown in chapter 1.

3. 2 Charles Méray

Another very interesting book is the one by Charles Méray, written in 1874, which reached its major success in 1901, when it was revived thanks to the new programmes for the teaching of mathematics of France.

In the introduction Méray criticizes the “disorder” of Euclid’s Elements. In particular, he states that the division between plane geometry and solid geometry makes no sense, because nature only presents objects in space (Méray 1874, p. XI). In his text, Méray substitutes most axioms with intuitive properties of motions in space (folding a piece of paper on itself, translating an object, rotating about a line).

The subdivision of the matter is not very different from Bretschneider, as in all other fusionist books, but in some chapters there is a *better integration of plane and space* thanks to the use of *geometric transformations*.

The chapters from 1 to 4 deal with intersection, perpendicularity, and parallelism of lines and planes, and with plane and dihedral angles.

Translation is defined as a motion of figures in space. Two lines are *parallel* if a *translation* maps the one onto the other (independently from being in a plane or in space). The same for *parallel* planes, and for lines parallel to a plane.

A plane is *perpendicular* to a line if it is mapped onto itself by the rotation about the line. Two lines are perpendicular if they meet and each of them is on a plane perpendicular to the other.

So, we can see that in these chapters plane and space are treated simultaneously and, for instance, perpendicularity between straight lines is defined using the perpendicularity between a plane and a line.

Not all chapters present such an integration, but we find it again in chapter 5, dealing with the comparison of segments. The *intercept theorem* (*Thales* theorem) about the proportion of segments is given both for plane and space. In chapter 10 areas are compared by means of a *projection* of an area on a plane (using trigonometry) (Méray 1874, p. 96, see Fig. 9).

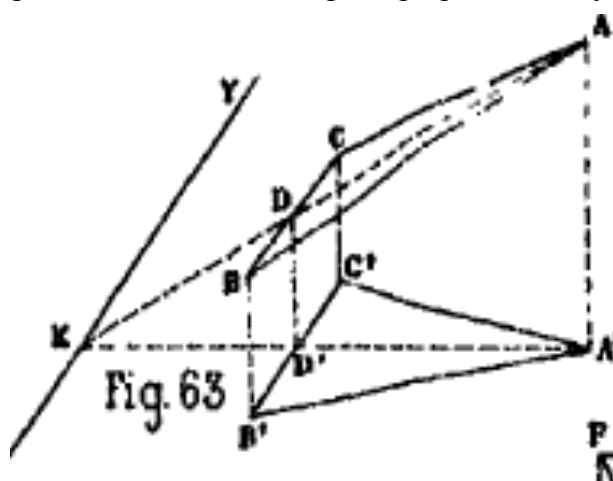
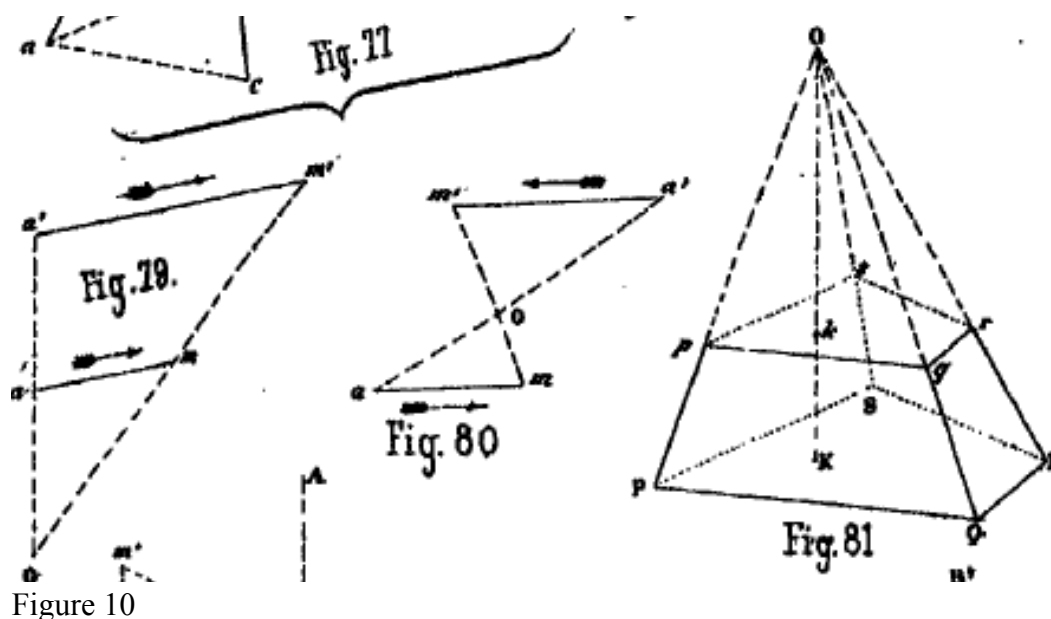

Figure 9

In chapter 13 *homothetic figures and similarity* are treated both in plane and in space. (ibid. p. 122, see Fig. 10)



Let us note that Méray presents separately the parabola, hyperbola and ellipse referring to their eccentricity. He never uses the term “conic sections”. Indeed, we can suppose that - being his a fusionist book - he would be then obliged to link the eccentricity to the definition of these figures as sections of the cone.

3. 3 Riccardo De Paolis

The textbook by the Italian Riccardo De Paolis of 1884 is mentioned in the review of the textbook by Lazzeri & Bassani published in 1911 in *l'Enseignement Mathématique* (see section 1).

In his introduction De Paolis writes:

There is a big analogy between certain figures in the plane and certain figures in the space; by studying them separately we renounce to know all that we can learn from this analogy, and we fall into useless repetitions. If we look for the properties of a line or a surface without being able to use the geometrical entities placed outside the line and the surface, we limit the forces we can dispose of and we renounce to geometric tools that would help to simplify constructions and proofs. In fact, how can you construct the midpoint of a given segment without leaving the segment itself? Instead, using the geometrical tools of a plane that contains it, the construction is known and very simple. How can one construct an isosceles triangle that has each of the two angles equal to twice the third? The triangle is easily constructed, and without applying the theory of equivalence or proportions, if we use the geometric objects placed outside its plane (page 92) (De Paolis 1884, p. III-IV).

The proof mentioned by De Paolis is not as easy as he states, but what is important in this last sentence is the fact that proofs can be performed without applying the theory of equivalence or proportions. Indeed, it is necessary to observe that if - as was the case in

Italy – the textbooks follow the books of Euclid, the theory of proportions takes much time and is quite difficult. Therefore the possibility to avoid it has a particular value.

Do not object that for beginners it is easier to conceive a plane angle than a dihedral angle; it is exactly because the mind of the students is forced to think and draw only flat figures in the first years of their geometric studies, that they find difficulties afterwards (ibid. p.IV).

In his book De Paolis gives much importance to geometric transformations, as Méray does. He also presents many interesting exercises and problems. But his proofs are often too long, being the author also much interested in rigour.

As in Méray, the first part of the book concerns properties of incidence and parallelism. Let's look, for instance, at the following theorem:

The angles formed by two intersecting lines are equal to those formed by two lines parallel to them, which meet (ibid., p. 33)

The formulation does not state if we are speaking of a plane theorem or of a theorem in solid geometry. This means that the theorem holds in both cases. The first part of the proof is performed in space and is based on the *sliding* of the pair of lines APC and BPD on the dihedral angle formed by the two couples of parallel lines $AC, A'C'$ and $BD, B'D'$... (Fig. 11)

Only afterwards De Paolis presents the proof for lines lying all in the same plane, which refers to previous theorems based on the properties of parallel lines.

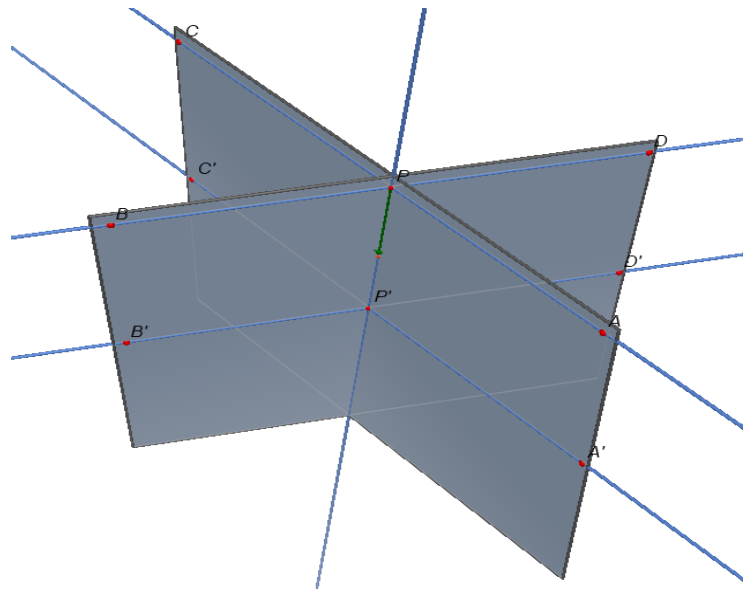

Figure 11

A further theorem presents what we could call a “fusionist” proof:

Given $ABC, A'B'C'$. Suppose that AA', BB', CC' all meet in P , and that $AB \parallel A'B'$ and $AC \parallel A'C'$; we want to prove that $BC \parallel B'C'$ (ibid., p. 92).

Figure 12

If the given triangles are *not* on the same plane, the proof is obvious: the two planes $ABC, A'B'C'$ are parallel, because of the hypotheses, and hence also $BC \parallel B'C'$ (Fig. 12).

If ABC and $A'B'C'$ are on a same plane, take two points Q, R on any line

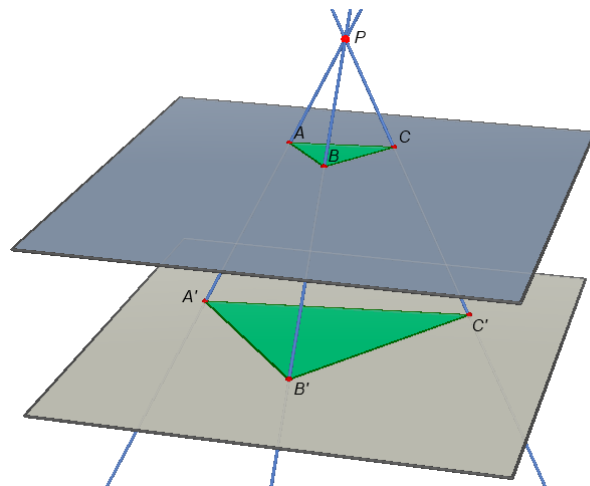

(in *space*) through P , from which we project the triangles. So we have twice the solid case. For the transitivity of parallelism, the proof is completed (Fig. 13).

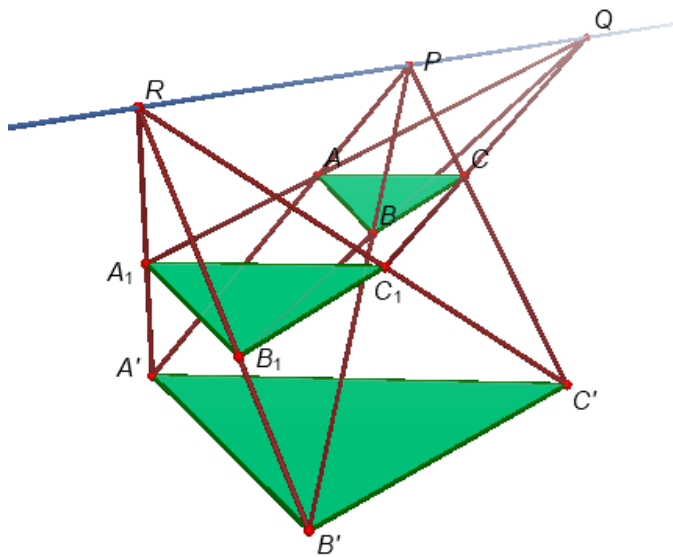

Figure 13

To follow the second part of the proof, we need to consider the same configuration of the first case, but looking at it differently: in the first case we “see” a solid configuration, in the second case a plane one.

Let us also note that this theorem is a particular case of the Desargues theorem, corresponding to the situation in which the intersection points of correspondent sides are on a line at infinity (i.e., correspondent sides are parallel). Hilbert shows that the Desargues theorem can be proven using only the incidence axioms for the space, and avoiding the congruence Axiom III, 5 (Hilbert, 1899).

3. 4 Giulio Lazzeri e Anselmo Bassani

We arrive now to the last and most important book presenting a fusionist approach: the book by Lazzeri and Bassani, which was written in 1891 for the pupils of the *Accademia Navale* (naval academy) in Livorno – at that time a secondary technical school – and had a second edition in 1898 devoted also to the *Lycées*.

The introduction is very similar to the one of De Paolis. The authors mention - as their predecessors - *Bretschneider*, *De Paolis*, *Angelo Andriani* (Andriani 1887; another Italian fusionist book) and – above all – *Monge*,

who showed the utility of the fusion by proving, with the help of three-dimensional figures, many theorems concerning plane figures in a very simple way (Lazzeri & Bassani 1891, p. X).

Moreover, they add that this method of proving plane theorems with the help of solid geometry “is well accepted today in projective geometry [...] and has now been realized also in elementary geometry” (ibid.).

Indeed, in the book by Lazzeri & Bassani the method is very often applied. Substantially there is no chapter in which plane and space are separated. Moreover, they state that they “succeeded in making many questions independent from the theory of proportions and of measures” (ibid., p. XI). A first example is given by the following theorem:

Two lines r and r' are given, with r parallel to r' , and A, B, C, D on r . Consider a point O and the lines OA, OB , etc. which cut r' in A', B', C', D' . We want to prove that if $AB = CD$ then $A'B' = C'D'$.

The theorem could be easily proven using proportions and similarity. But we can find a different proof that avoids the theory of proportions:

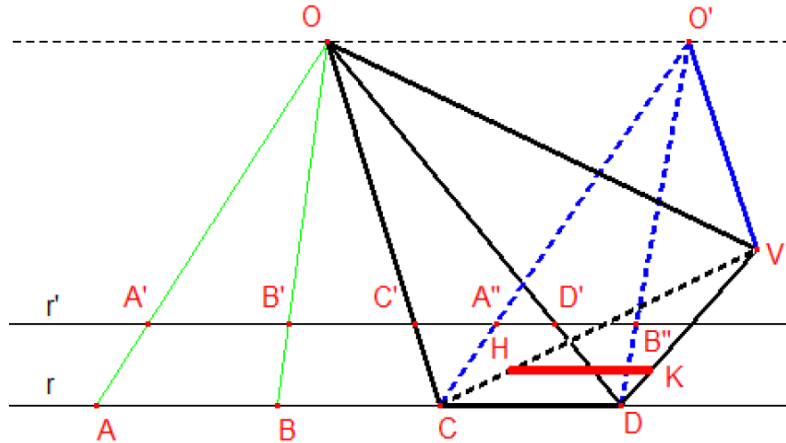

Figure 14

with reference to Fig. 14, move OAB to $O'CD$, so that $A'B' = A''B''$.

Take V not on the plane of the figure, and consider the tetrahedra $OCDV$ and $O'CDV$ and a plane containing r' parallel to the plane $VO'O''$: this plane intersects the triangle VCD (common to the two tetrahedra) in HK .

A previous theorem states that in a tetrahedron we can always consider a plane parallel to two opposite edges and at an intermediate distance from them. This plane cuts the tetrahedron in a parallelogram (fig. 15). Thanks to this theorem we have that $HKC'D'$ and $HKA''B''$ are parallelograms; therefore $HK = A''B'' = A'B'$; $HK = C'D'$, hence $A'B' = C'D'$.

This proof only involves questions of parallelism and intersection. It is not a difficult proof, if we have the habit to “see” in space.

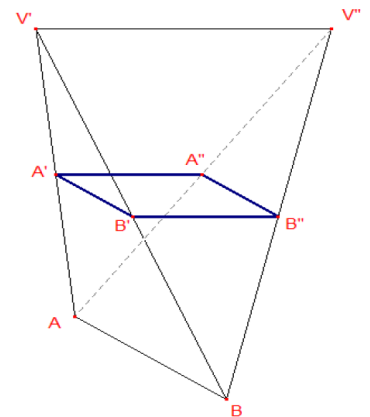

Figure 15

Let us look at second example, with the following theorem:

Given two circumferences c_1, c_2 ($c_1 \neq c_2$) on the plane, the locus of points such that the tangent segments led from each point to the two circumferences are equal is a straight line perpendicular to the line joining the two centres, and external to the circumferences if the circumferences are the one external to the other (Fig. 16)

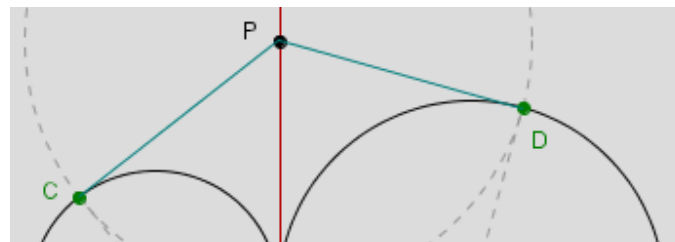

Figure 16

The proof refers to Fig. 17, which is taken from Lazzeri & Bassani (1891, p. 188). Consider two equal spheres S_1, S_2 passing through c_1, c_2 , with centres O'_1, O'_2 . Take $\beta \perp \overline{O'_1 O'_2}$ in its midpoint (plane of reflection of S_1, S_2).

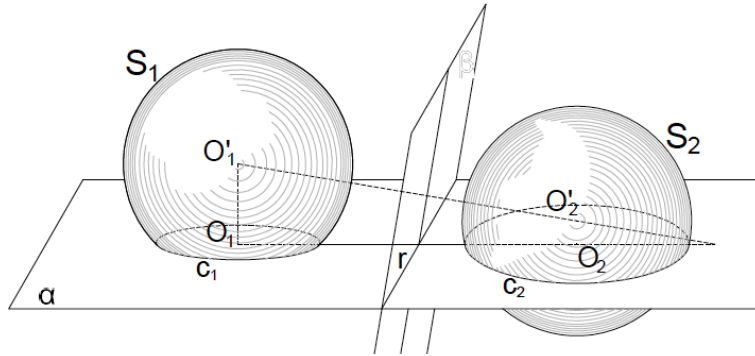

Figure 17

Call $r = \beta \cap \alpha$; r is the locus on α such that the tangent segments led from each point to the two spheres are equal and hence also to the two circles. We show that $r \perp \overline{O_1 O_2}$: the perpendiculars to α through O'_1, O'_2 meet α in O_1, O_2 and form a plane $\gamma \perp \alpha$, containing $\overline{O_1 O_2}, \overline{O'_1 O'_2}$. Also β is perpendicular to γ being $\beta \perp \overline{O'_1 O'_2}$, so planes α and β meet in a line $r \perp \gamma$ and hence $r \perp \overline{O_1 O_2}$.

The book by Lazzeri and Bassani presents very interesting and beautiful proofs. It is not easy to judge its difficulty without knowing in depth the teaching methods of such a topic in that period, and in particular of Lazzeri himself, who was a teacher in the naval academy. Indeed, at the time the book was well considered by teachers, but the question does not have a definite answer, as we can see in the next section.

4. Discussions about the question

In 1899 the Journal *l'Enseignement Mathématique* published a paper by Giacomo Candido, where the author describes the debate that takes place in Italy, presenting the arguments *against fusion* and the arguments *in favour of fusion* (Candido, 1899).

Against the fusion are the programmes of the *Lycées*, which present stereometry only in the third year, following the same order of Euclid; moreover the fusion seems too difficult, too much linked to systematization (with reference both to De Paolis and to the book of Andriani, who – according to Candido – found “non-existing connections” between plane and space).

In favour of fusion are the fact that it is time saving (it is not necessary to repeat certain parts of the school programs) and allows a simplification of some considerations on planimetry by explaining them through considerations in space. Furthermore, it allows a major harmony between the study of mathematics and that of other topics.

The author mentions the book by Lazzeri & Bassani among the arguments in favour of fusion. Indeed, it contains better proofs “through” space. The success in a technical institute (the *Accademia Navale* of Livorno, where Lazzeri was a teacher) brought the book to be used also in *Lycées* (Candido, 1899).

The Italian association of mathematics teachers *Mathesis* published different discussions and also asked to change the programs so as to allow fusion (Borgato 2006 and 2016).

Again in *l'Enseignement Mathématique*, Méray presents the 1903 edition of his *Eléments* (Méray, 1904) with a big critique to Euclid, as contained in the introduction of the book (see 3.2). He mentions the great Italian “fusionist” school, but notes that his book was written earlier.

In the second book of the series on *Elementary Mathematics from a higher standpoint*, first published in 1908 with a new English translation in 2016, Felix Klein presents the book by Scheffers & Kramer (1925):

The text is based on the view that for the development of the best possible space intuition, the fusion between planimetry and stereometry has to be dealt with more systematically and from an earlier time in school than has happened so far. If we start to realise this idea of fusion, we encounter soon the necessity to perform spatial constructions graphically and to imagine solids on the plane. The planimetry-stereometry-fusion urges therefore a broader notion of fusion, which comprises descriptive geometry (Klein, 2016, p. 303).

In a book of 1928 discussing the teaching of geometry in German schools Kuno Fladt states:

Already in the 1840s the need was felt of merging stereometry closely with planimetry. Even if too much weight was given at that time to a scientific systematization, there was anyway an educational idea: that the pupil who has to do only with planimetry is almost educated to “space blindness”. Both types of reasons lead in Italy to an extended “fusion” of planimetry and stereometry. But there was a setback: the too early and extended employment of stereometry turned out to be too difficult.

This does not exclude that, on the one hand, in the first teaching of geometry plane objects are shown on solids, from which they are then abstracted, and that, on the other hand, when presenting new plane figures, we always consider and present the solid bodies in which they can be found. This is a “moderate fusion” as now required in the new programmes of Württemberg of 1926/27 (Fladt 1928, p. 126)

A compromise is indeed often a good solution, and this can happen also in the case of fusionism. A presentation of the incidence properties as presented in the first chapters by Méray is surely a wonderful help to space representation.

In the case of conic sections, proofs as the one by Apollonius or by Dandelin allow the link between different definitions of conic sections, which is not usual in schools.

But also other suggestions come from this historical overview, which could help the construction of a curriculum that avoids “space blindness”.

REFERENCES

- Andriani, A. (1887). *Elementi di geometria euclidea esposti con nuovo metodo*. Napoli: Pellerano.
- Barbin, E. (to appear). Monge’s Descriptive Geometry: His Lessons and the Teachings given by Lacroix and Hachette. In E. Barbin, M. Menghini, & K. Volkert (Eds.), *Descriptive Geometry, the Spread of a Polytechnic Art*. Cham: Springer Nature
- Barbin, E., Menghini, M. (2013). History of teaching geometry. Chapter XXVII in A. Karp & G. Schubring (Eds), *International Handbook on the History of Mathematics Education*. New York: Springer-Verlag
- Book review (1911). G. Lazzeri und A. Bassani. — Elemente der Geometrie (Unter Verschmelzung von

- ebener und räumlicher Geometrie). — Aus dem Italienischen übersetzt von P. Treutlein. — 1 vol. in-8°, XVI-491 p.; 14 M.; B. G. Teubner, Leipzig, 1911. *L'Enseignement Mathématique*, 13, 429 – 430
- Borgato, M. T. (2006). Il fusionismo e i fondamenti della geometria. In Giacardi L. (Ed.), *Da Casati a Gentile, momenti di storia dell'insegnamento secondario della matematica in Italia* (pp. 125-157). Lugano: Lumières Internationales.
- Borgato, M. T. a (2016). Il fusionismo: moda didattica o riflessione sui fondamenti della geometria? *Periodico di Matematiche*, s. XII 8(2), 45-65.
- Bretschneider, C. A. (1844). *Lehrgebäude der niederen Geometrie: für den Unterricht an Gymnasien und höheren Realschulen*. Jena: F. Fromann
- Candido, G. (1899). Sur la fusion de la planimétrie et de la stéréométrie dans l'enseignement de la géométrie en Italie. *L'Enseignement Mathématique*, 1, 204 – 215.
- Cateni, L., Fortini, R. (1958) *Il pensiero geometrico*. Firenze: Le Monnier
- Dandelin, P. G. (1822). 1^o Mèmoire sur les propriétés remarquables de la focale parabolique. *Nou. Mèm. De l'Acad. Des Sci. Bruxelles*, II, 169-202
- De Paolis, R. (1884). *Elementi di geometria*. Torino: Loescher.
- Fehr H. (1911). Compte rendu du congrès de Milan. *L'Enseignement Mathématique*, 13, 437-511. A. II. — La question de la fusion des différentes branches mathématiques dans l'enseignement moyen. 468 – 470
- Henrici J., Treutlein P. (1881-1883). *Lehrbuch der Elementar-geometrie*, 3 v. Leipzig: B.G. Teubner.
- Hilbert, D. (1899). *Grundlagen der Geometrie*. Leipzig: Teubner
- Klein, F. (2016). *Elementary Mathematics from a Higher Standpoint*. Volume II: Geometry. Berlin/Heidelberg: Springer
- Kuno Fladt (1928). *Elementargeometrie: Der Stoff bis zur Untersekunda*. Tübingen: Teubner
- Lazzeri, G., Bassani, A. (1891). *Elementi di geometria*: libro di testo per la R. Accademia Navale. Livorno: Giusti (2d ed. 1898).
- Méray, C. (1874/1903). *Nouveaux éléments de géométrie*. Paris: Savy
- Méray, C. (1904). Justification des procédés et de l'ordonnance des nouveaux Éléments de géométrie 1, *L'Enseignement Mathématique*, 6, 89 – 123,
- Monge, G. (1799). *Géométrie descriptive*. Paris: Beaudoin.
- Monge, G. (1847). *Géométrie descriptive*. Paris: Bachelier.
- Scheffers, G., Kramer, W. (1925). *Leitfaden der darstellenden und räumlichen Geometrie*. I Teil für Untertertia bis Untersekunda. Leipzig: Quelle & Meyer
- ver Eecke, P. (1963), *Les coniques d'Apollonius de Perge*. Paris: Librairie Albert Blanchard