

DAMAGE CHARACTERIZATION IN WAVEGUIDES WITH ULTRASONIC SHEAR WAVES

Dimitra V. Achillopoulou¹, Annamaria Pau², and Fabrizio Vestroni³

¹ Dipartimento di Ingegneria Strutturale e Geotecnica,
Universita' di Roma La Sapienza, via Eudossiana 18, 00185 Roma, Italia
e-mail: dimitra.achillopoulou@uniroma1.it

² Dipartimento di Ingegneria Strutturale e Geotecnica,
Universita' di Roma La Sapienza, via Gramsci 53, 00197 Roma, Italia
annamaria.pau@uniroma1.it

³ Dipartimento di Ingegneria Strutturale e Geotecnica
Universita' di Roma La Sapienza, via Eudossiana 18, 00185 Roma, Italia
vestroni@uniroma1.it

Keywords: wave propagation, frp laminate, damage characterization, acoustic waveguides

Abstract. *Damage can be viewed as a continuum discontinuity. In order to identify and quantify damage, the present study investigates the dependence of reflection and transmission coefficients from a discontinuity in a waveguide using a finite element model. A parametric study of a fiber reinforced polymer laminate beam is presented with five different ratios of reduced cross-section with two different kinds of geometry: symmetric and asymmetric, in three discontinuity lengths. What is more, finite element results are compared with the corresponding results of a semi-analytical model based on the principle of reciprocity in elastodynamics. The analysis shows that: a) depending on the kind of discontinuity, the diagnostic potential of the used guided wave depends on the mode existence and on the magnitude of its wavelength in relation to the discontinuity extension, b) reflection and transmission coefficients can be used to identify and characterize damage both in symmetrical and asymmetrical damaged cross sections.*

1 INTRODUCTION

Guided wave propagation plays an important role in non-destructive tests and health monitoring of structures. Several applications to analyse different conditions, such as corrosion, state of prestress, defects, cracks, can be found in literature [1-3]. Such monitoring techniques are based on the fact that, in the presence of discontinuities, waves interact with cracks and voids [5-6]. The amplitude and shape of the resulting scattered field is related to the characteristics of the defect and may be used in an inverse problem to detect and characterize discontinuities themselves.

The current study deals with the characterization of the response of a waveguide with a discontinuity consisting in a double change of cross-section. Such a discontinuity conventionally represents a notch. A finite element simulation of the propagation of shear waves in a plate has been performed. Two different geometries for the discontinuity are considered, that is symmetric and asymmetric (one-sided). The asymmetric damage is the most common damage that exists in practice, therefore it is of high interest to investigate on the response of waveguides in this case. Three different damage lengths and five different percentages of cross section reduction are investigated. The results for the symmetric case have been compared to the analytical results of a semi-analytical model based on the principle of reciprocity in elastodynamics [7].

2 DESCRIPTION OF THE FE MODEL

The simulation was performed using a proper finite element software (Ansys) [8]. The specimens were chosen in order to simulate an FRP laminate (Table 1) used to rehabilitate long concrete bridge spans.

E modulus of Elasticity [MPa]	Density ρ [kg/m ³]	Poisson ratio ν	Shear Wave Velocity c_s [m/s]
165000	1600	0.2	6555.5

Table 1: FRP mechanical properties

The laminate was modeled as a 3D solid using SOLID185 element which is defined by eight nodes having three degrees of freedom at each node. The solid used is a parallelepiped with height $h=0.10$ m, thickness $s=0.003$ m and length $L=12$ m with all the displacements restrained at one end. It is meshed allowing prism and tetrahedral degenerations of elements in irregular regions. A mesh of appropriate density was chosen in order to properly describe wave propagation. The symmetric and asymmetric discontinuities consist in a double change of cross section as shown in Figure 1, whose geometry is described through the parameters length (l_d) and height of reduced cross section (s_r).

The structure is excited with a force whose time-history is a high-frequency sine burst with frequency $f=12000$ Hz, applied at the free-end and acting along direction y . All the nodes are constrained according to directions x and z since pure shear waves are generated.

The investigated damage geometry (l_d, s_r) is described using the non-dimensional ratio λ/l_d , where λ is the wavelength of the shear wave propagating in the plate ($\lambda=c_p/f$), and $r = l-s_r/s$ is a measure of notch magnitude ($r=0$ corresponds to no damage, $r=1$ to a fully cracked cross section). The ranges of values of λ and r used in the analysis are collected in Tables 2 and 3.

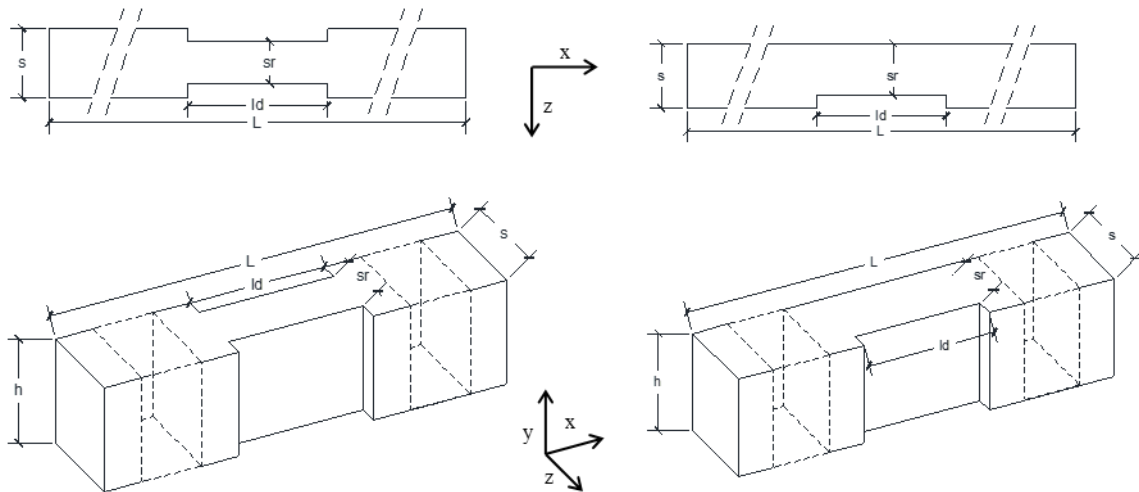

Figure 1: Discontinuities on FRP laminate specimens (m).

l_d [m]	1.09	0.55	0.27
λ/l_d	0.5	1	2

Table 2: Discontinuity length

s_r [m]	0.00249	0.00201	0.00150	0.00099	0.00051
r (%)	17	33	50	67	83

Table 3: Discontinuity thickness

3 RESULTS

The forcing function is applied at the free end of the laminate and acts in y direction. It generates an incident wave travelling along the waveguide and interacting with the cross-section reduction. At every geometric change, part of the wave is reflected and part is transmitted in a way which depends on the characteristics of the discontinuity.

The current study focuses on the investigation of transmissions and reflections as a function of damage geometry. The amplitude of the scattered field is extracted from the amplitude of the response of nodes located close to the discontinuity (1m before and after the starting/ending abscissa of the damaged area). Figure 2 sketches the way amplitudes were extracted. A describes the maximum amplitude of the incident wave, while A_t and A_r are the maximum amplitudes of the transmitted and reflected wave, respectively.

3.1 Reflections and Transmissions

The amplitude of the scattered fields is shown in Figures 3 and 4 for the symmetric and asymmetric case. The reported amplitudes of both transmitted and reflected wave are normalized to the value of the amplitude of the incident wave.

Figures 3 and 4 respectively show the amplitude of the transmitted and reflected fields, which varies as a function of r and of the ratio λ/l_d . In cases of deep damage (r close to 1) the transmitted amplitude (A_t/A) is reduced while the reflected (A_r/A) rises, meaning that in heavily damaged cross sections ($r > 83\%$) the wave cannot be fully transmitted and tends to be reflected. On the contrary, when r is small, the travelling wave is nearly entirely transmitted.

Speaking about the dependence of these coefficients from the ratio λ/l_d , as the wavelength λ of the incident wave becomes of the same order of magnitude of the damaged length or larger (Figure 3a, b, c and Figure 4a, b, c: $\lambda/l_d=0.5, 1$ or 2) the response tends to be more sensitive to the presence of the notch because the curves are less sharp than for higher values of λ/l_d [6]. This is due to the fact that the waves are reflected from the first and second change in cross-section and can interact in different ways, constructively or destructively. As shown in [6], to detect small damage, small wavelength are to be used. If the wavelength is large, the destructive interference hides the presence of discontinuities.

As far as the differences noted from the symmetric and asymmetric specimens are concerned, in cases of small λ/l_d ratio (0.5), meaning an extensive damage, the results coincide. The results tend to differentiate when the ratio λ/l_d increases, that is when the wavelength is large in relation to the damaged length. The maximum discrepancy observed (12%) is for the transmission coefficient and $\lambda/l_d= 2$ (Figure 3c). Reflection coefficients do not present appreciable difference between the symmetric and asymmetric case.

The frequency used (12kHz) is actually too low to detect differences in response of the symmetric and asymmetric damaged cross-section. The difficulty in observing mode conversion due to the asymmetry of the cross-section strongly depends on the existence of shear modes at the frequency under investigation. As is shown in Figure 5, which reports the group velocity (c_G) as a function of frequency, at 12000 Hz only the first symmetric mode exists. In this way, differences between the symmetric and asymmetric case are small.

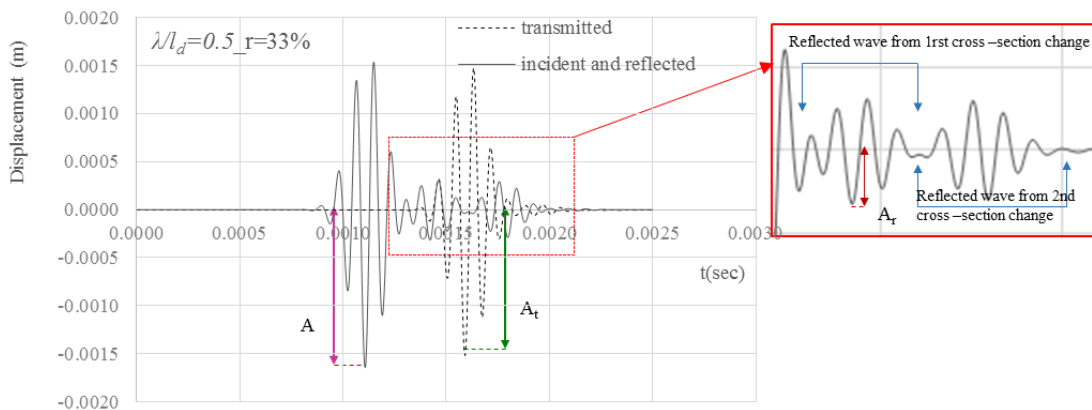

Figure 2: Sample time history

3.2 Comparison of SAFE and FEA

The results obtained from the FE model were compared with a semi-analytical finite element model (SAFE, [4]), where the scattered fields are studied exploiting the principle of reciprocity in elastodynamics (see ref. [7] for all details):

$$\int_{S_i} (\sigma_{ij}^B u_j^A - \sigma_{ij}^A u_j^B) n_i dS + \int_{S_0} (\sigma_{ij}^B u_j^A - \sigma_{ij}^A u_j^B) n_i dS = 0 \quad (3)$$

where the superscript A refers to the response of a waveguide in the presence of a discontinuity and B to the waveguide response to a virtual wave propagating in the absence of the discontinuity. The reflected and transmitted fields in case A are expressed as a linear superposition of reflected and transmitted waves whose coefficients for the p -th wave A_r/A and A_t/A depend on

the q -th incident wave. The linear superposition is a series which theoretically should extend to all the modes existing at the given frequency, however, for the frequency chosen and the width of the specimens investigated it only the first symmetric shear wave mode exists. This is shown in Figure 5, therefore, only this mode is taken into account in the semi-analytical model.

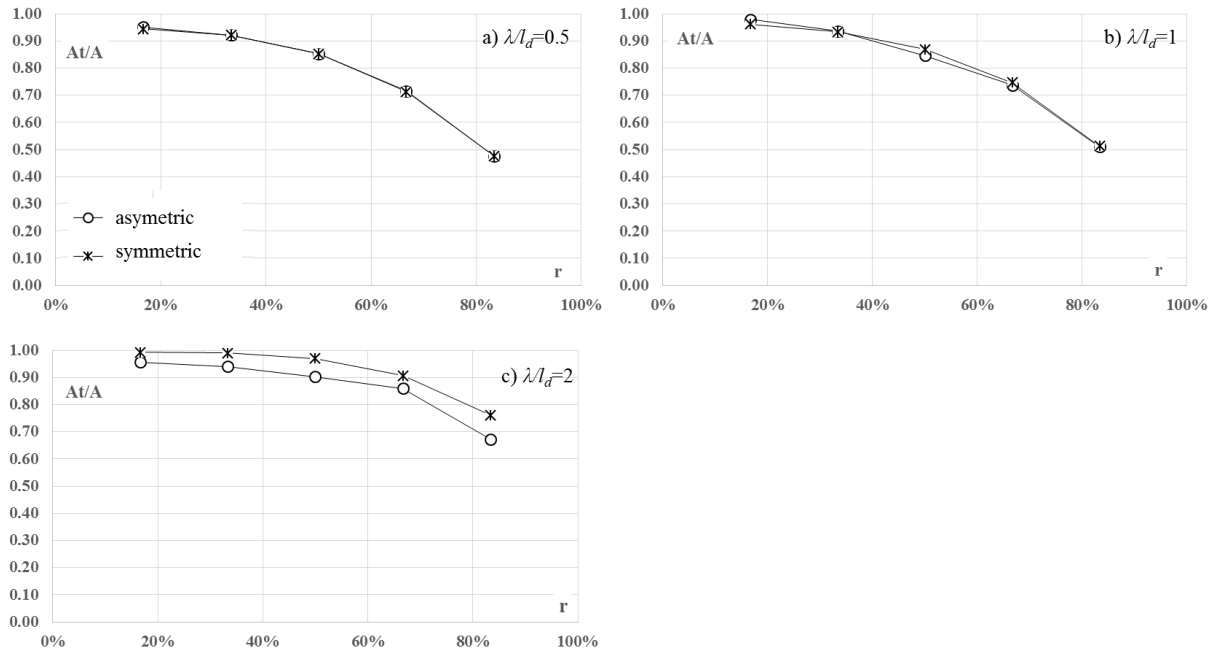

Figure 3: Transmission coefficients as a function of different ratios of cross section reduction for different damage lengths (FEA): a) $\lambda/l_d=0.5$, b) $\lambda/l_d=1$, c) $\lambda/l_d=2$

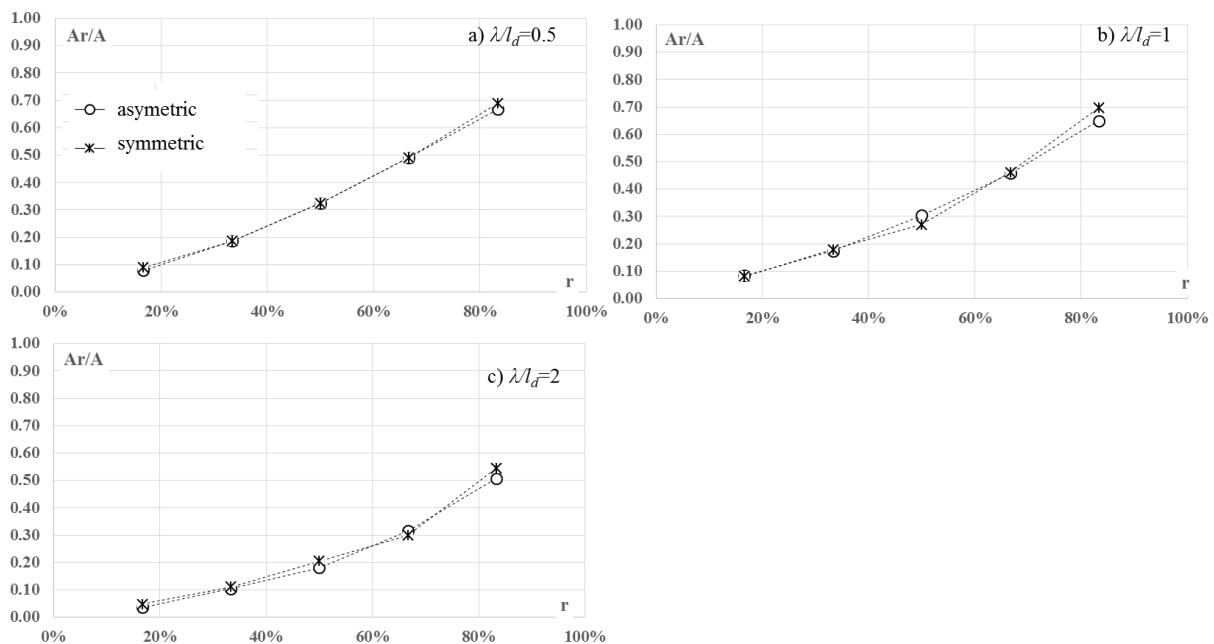

Figure 4: Reflection coefficients as a function of different ratios of cross section reduction for different damage lengths (FEA): a) $\lambda/l_d=0.5$, b) $\lambda/l_d=1$, c) $\lambda/l_d=2$

A comparison between the scattering coefficients obtained from the principle of reciprocity and from the FE analysis is reported in Figure 6 for the symmetric case only. The difference between the values varies as a function of cross section reduction (r) and in general is greater for the transmitted coefficient than for the reflected.

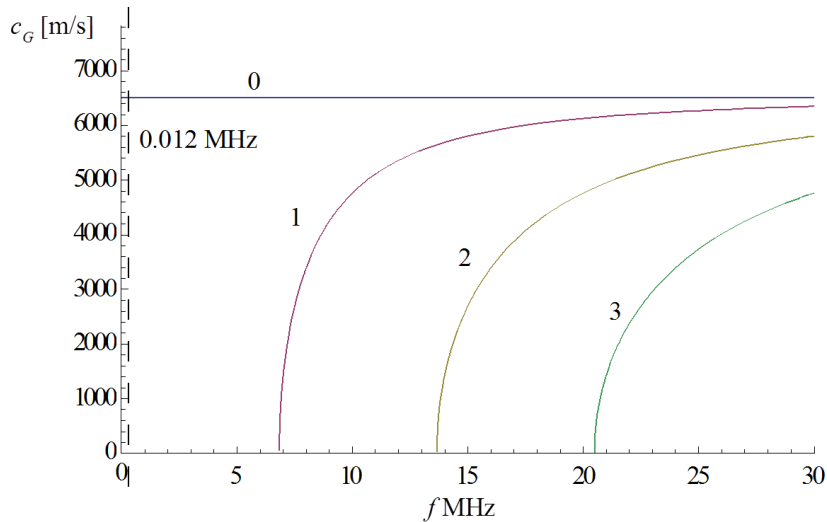

Figure 5: Phase velocity c_G as a function of frequency f .

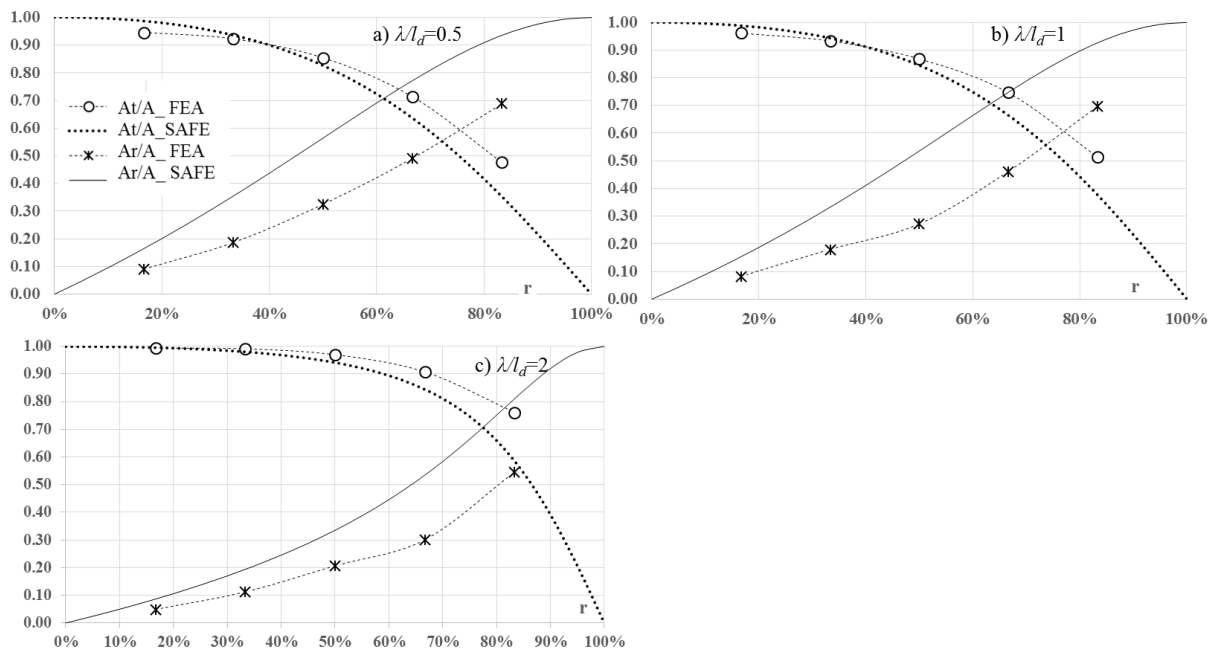

Figure 6: Comparison of reflection and transmission coefficients in SAFE and FEA model.

These differences are due to the fact that part of the energy in the FEA is lost due to numerical damping. This is shown in Figure 7 which reports the quantity $\left((A_r / A)^2 + (A_t / A)^2 \right)^{1/2}$ which is a measure of the conservation of energy. Data are reported for all the cases under study both for FEA and SAFE results. While SAFE model always provides a unit value, for FEA the values are always smaller. In order to investigate the loss of energy, an undamaged FE model

was considered. The ratio between kinetic energies of the response measured at the points 1 and 2, where $A_r(l_d-1)$ and $A_t(l_d+1)$ were extracted, was calculated as

$$\int_0^T v_2^2 dt / \int_0^T v_1^2 dt$$

for the ratio $\lambda/l_d = 1$ only, providing 0.95. This value confirms that in the FE model a certain amount of energy loss occurs.

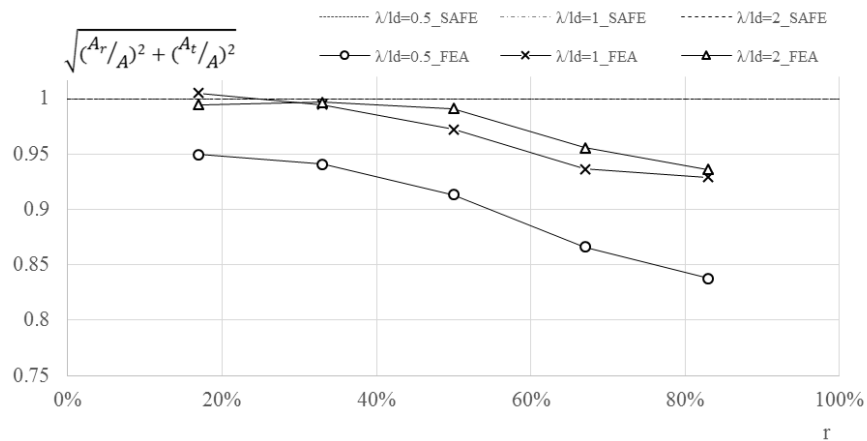

Figure 7: Energy conservation curves.

4 CONCLUSIONS

The current study focuses on the characterization of the scattered field from discontinuities in plates by observing the shear wave response. Two different kinds of discontinuities are examined, that is symmetrical and asymmetrical change of cross-section. The results of a FE model were compared with those of a semi-analytical model. For five different cross section reductions and three damage lengths (l_d), the amplitude of transmitted and reflected waves was observed. It is noted that the scattered field depends on the severity of damage which makes it a suitable quantity to be used in an inverse problem, provided that waves with wavelength of the same order of magnitude in respect to the extension of damage are used. The differences reported in both scenarios of symmetric and asymmetric damaged cross sections are small especially in cases with extended damage. The use of high frequencies is suggested in cases of asymmetric damage, as higher wave modes enable to more precisely detect the presence of asymmetries in the cross-section. The SAFE results are in acceptable agreement with the FEA results of the symmetric scenario, making such method appropriate to be applied even in more complex cases. It is also observed that the FE model exhibits lacks in conservation of energy due to numerical damping that varies as a function of the reduction of the cross-section.

REFERENCES

- [1] Schoefs F., Abraham O., Popovics J.S., Quantitative evaluation of contactless impact echo for non-destructive assessment of void detection within tendon ducts, *Construction and Building Materials* (2012), 37, pp. 885-892.
- [2] Rose J.L., Pilarski A., Ditri J.J. Approach to guided wave mode selection for inspection of laminated plate, *Journal of Reinforced Plastics and Composites* (1993), 12 (5), pp. 536-544.
- [3] Park S., Ahmad S., Yun C.-B., Roh, Y., Multiple crack detection of concrete structures using impedance-based structural health monitoring techniques, *Experimental Mechanics* (2006), 46 (5), pp. 609-618.
- [4] Marzani A., Viola E., Bartoli I., Lanza di Scalea F., Rizzo P., A semi-analytical finite element formulation for modeling stress wave propagation in axisymmetric damped waveguides, *Journal of Sound and Vibration* (2008), 318 (3), pp. 488-505.
- [5] Rose J.L., *Ultrasonic Guided Waves in Solid Media*, Cambridge University Press, (2014).
- [6] Pau A., Vestroni F., Wave propagation in one-dimensional axial waveguides for damage characterization, *Journal of Intelligent Material Systems and Structures* (2011), 22 (16), pp. 1869-1877.
- [7] Pau A., Capecchi D., Vestroni F., Reciprocity principle for scattered fields from discontinuities in waveguides, *Ultrasonics* (2015), 55, pp. 85-91.
- [8] Ansys Tutorials, 2014