



SAPIENZA | Centro Interuniversitario per la Ricerca sulla Genesi e sullo
UNIVERSITÀ DI ROMA | Sviluppo delle Motivazioni Prosociali e Antisociali
CIRMPA

Doctorate in
Prosociality, Innovation And Collective Efficacy in Educational
And Organizational Contexts

XXVI cycle

Doctoral Dissertation:
*Ego-resiliency: Determinants and outcomes
from adolescence to emerging adulthood*

Phd Candidate
Miloni Michela

Tutor
Prof. Gian Vittorio Caprara

To my parents

To Davide

TABLE OF CONTENTS

INTRODUCTION.....	Page 5
1. The development of the construct of ego-resiliency.....>>	6
1.1 Ego-resiliency and successful adaptation during the stages of life.....>>	7
1.2 Ego-resiliency during emerging adulthood.....>>	9
2. Outline of the dissertation.....>>	10
3. Genzano longitudinal study.....>>	12
References.....>>	14
CHAPTER I. The role of positivity as predictor of ego-resiliency.....>>	21
1. Introduction.....>>	21
2. Positivity (POS).....>>	22
3. Relation between positivity and ego-resiliency.....>>	24
4. The present study.....>>	25
5. Method.....>>	26
5.1. Participants.....>>	26
5.1.1. Attrition and missing data analysis.....>>	26
5.2. Procedure.....>>	27
5.3. Measures.....>>	29
5.4. Statistical analyses.....>>	29
6. Results.....>>	30
1.1 Descriptive statistics.....>>	30
1.2 Modeling strategies.....>>	32
1.3 Longitudinal modeling analyses.....>>	33
1.4 Autoregressive and cross-lagged path and concurrent relations.....>>	33
1.5 Explained variance.....>>	35

2. Discussion	>> 35
References	>> 38

CHAPTER II. The reciprocal relation between emotional self-efficacy and ego-resiliency

across time	>> 44
1. Introduction.....	>> 44
2. Emotional self-efficacy beliefs	>> 44
3. Relations between ego-resiliency and emotional self-efficacy beliefs	>> 47
4. Aim of the present study	>> 48
5. Method	>> 50
5.1 Participants	>> 50
5.1.1. Attrition analyses	>> 51
5.2 Procedure.....	>> 51
5.3 Measures.....	>> 53
5.4 Preliminary analyses	>> 54
6. Results	>> 54
6.1. Descriptive statistics.....	>> 54
6.2. Modeling strategies	>> 57
6.3. Structural equation analysis	>> 57
6.4. Longitudinal modelling	>> 58
7. Discussion	>> 62
Reference.....	>> 66

CHAPTER III. The predictive role of ego-resiliency in behavioral problems.....>> 73

3. Introduction.....	>> 73
4. Relation between ego-resiliency and behavioral problems.....	>> 74
5. The present study	>> 76
6. Method	>> 76

4.1	Participants.....	>> 76
4.1.1.	Attrition and missing data analysis	>> 77
4.2.	Procedure.....	>> 77
4.3.	Measures.....	>> 78
4.4.	Statistical analyses.....	>> 78
7.	Results.....	>> 79
5.1.	Descriptive statistics.....	>> 79
5.2.	Modeling strategies	>> 81
5.3.	Longitudinal modelling.....	>> 83
5.4.	Autoregressive, cross-lagged paths and concurrent relations	>> 83
5.5.	Effects of covariates.....	>> 84
5.6.	Variance explained.....	>> 84
5.7.	Estimates of the remaining cross-lagged paths	>> 84
8.	Discussion	>> 86
	References.....	>> 89
	GENERAL CONCLUSION.....	>> 95
	References	>> 98
	Acknowledgements.....	>> 99

INTRODUCTION

Human beings typically encounter a variety of difficulties and challenges during the course of their lives, ranging from daily hassles to major life events. Each person, during the course of his or her existence, is bound to face transitions and tasks that represent real challenges for balance and individual development. In this regard, in human history there are some examples of groups and individuals who have been able to turn unfavorable conditions or situations around to resist, cope, transform, integrate and build personal and collective resources to overcome difficult life experiences. On the other hand, others are extremely troubled by the inevitable hardships of everyday life. Based on this consideration, researchers in the field of individual differences have focused on examining personality traits that seem to be associated with successfully overcoming adversity, identifying the characteristics of individuals who thrived while living in difficult circumstances such as poverty and parental mental illness (Garmezy, 1991; Rutter, 1990; Werner & Smith, 1992).

Focusing on the interaction between individual and environment, some authors (Rutter, 1990; Masten, Best & Garmezy, 1990; Milgram & Palti, 1993) used the concept of resilience to indicate a universal ability to cope with frustrating events and maintain a good level of adjustment.

It is a coping skill related to particular personality traits and personal characteristic able to counteract and neutralize the risk factors (Rutter, 1985; 1990).

One of the main difficulties in conducting research on resilience is that wide discrepancies exist in how it has been defined and conceptualized. In fact, a concept that is terminologically very similar to resilience, but that has different connotations, is ego-resiliency (Block & Block, 1980; this construct will be explained in detail in the next section). This dissertation, focusing on ego-resiliency, starts with a general analysis of the construct and seeks to analyze the consequences and the correlates of this personality trait.

1. The development of the construct of ego-resiliency

The concept of ego-resiliency was introduced by Block (1980), together with the concept of ego-control, to indicate two important personality dimensions that can significantly affect the interaction between an individual and the environment and his behavioral strategies. These constructs have been proposed within a personality theory where the Ego has the task of controlling impulses and facilitating the individual's adaptation to reality (Block & Block, 1980).

Ego-control concerns the degree of control that individuals exercise over their own impulses, desires and emotions, in other words the regulatory mode of their own inner world. Ego-control represents a continuum where at one extreme we find the *overcontroller* - individuals who have a high control of impulses and desires - and at the other extreme we find the *undercontroller* - individuals inclined to give free rein to their emotions and impulses (Block & Block, 1980; Block & Kremen, 1996).

Instead, the concept of ego-resiliency, indicates the ability to flexibly and elastically modify one's level of ego-control in both directions, conciliating the satisfaction of own needs with the demands and rules of the environment. This capability allows the individual to live better and to adapt effectively to the demands of the environment (Block & Block, 1980; Block & Kremen, 1996). In this regard, various studies have demonstrated that ego-resiliency correlates positively with

sociability, good humor, empathy, spontaneity, lack of rumination and the ability to resist at stress (Klohn, 1996). The opposite of ego-resiliency, ego-brittleness consists of limited and not very adaptive behaviors that predispose the individual to the adopt dysfunctional coping strategies, especially during changes and the difficulties (Block & Block, 1980).

In summary, the term ego-resiliency describes a set of traits reflecting general resourcefulness, strength of character and flexibility of functioning in response to varying environmental demands. Individuals with high levels of ego-resiliency are characterized by high level of energy, a sense of optimism, curiosity, and the ability to detach and conceptualize problems (Block & Block, 1980).

Based on Block's work, a qualitative study by Wagnild and Young (1993) identified a cluster of personality traits that seem to facilitate adaptation after a loss. These features included a balanced view of life, perseverance, self-confidence, sense of uniqueness, attribution of meaning to life. Benard (1991) considered as crucial characteristics of resilient individuals autonomy, problem solving skills, social skills and intentions for the future. Instead, Cramer (2000) considered good intelligence, creativity, imagination, and pleasure derived from playing for children as more important. Other important resilient characteristics were identified by scholars who followed the positive psychology approach and these included happiness (Buss, 2000), subjective well-being (Diener, 2000), optimism (Peterson, 2000), faith (Myers, 2000), self-determination (Ryan & Deci, 2000), wisdom (Baltes & Staudinger, 2000) and creativity (Simonton, 2000).

1.1. Ego-resiliency and successful adaptation during the stages of life

Block and Block (2006) stated that ego-resiliency represents a protective factor against negative outcomes in major domains of life. Resilient individuals (i.e., individuals high in ego-resiliency) showed better adjustment and higher attainments at all stages of life (Block & Block, 1980). They actively shaped the world and made their environment more compatible with their personality due to their ability to successfully cope with changing environmental circumstances

(Block & Block, 2006). Resilient individuals were also more likely to receive positive feedback regarding their behavior, had little need for change, demonstrated more stable personality patterns, and thus attained a better personality-environment fit (Asendorpf & van Aken, 1991).

Research has demonstrated the influence of ego-resiliency on personal and social functioning throughout diverse phases of development. In infancy, ego-resiliency was associated with secure attachment and better preschool problem-solving ability (Arend, Gove, & Sroufe, 1979). In childhood, ego-resiliency was associated with empathic behavior toward peers (Strayer & Roberts, 1989), adaptability (Wolfson, Fields, & Rose, 1987) and socially competent behaviors (Eisenberg et al., 2004; 2003) under stressing circumstances (Luthar, 1991). On the other hand, low levels of ego-resiliency predicted later use of age-inappropriate defense of denial (Cramer & Block, 1998) and were related to children's egocentrism, although with different implications for boys and girls (in this regard, see Gjerde, Block, & Block, 1988).

In adolescence, high levels of ego-resiliency were linked to personality maturity (Westenberg & Block, 1993), to appropriate delay of gratification behavior (Funder & Block, 1989; Mischel, Shoda, & Peake, 1988), and to the "well adjusted pole" of the Big Five (McCrae & Costa, 1999) dimensions (Caprara, Steca, & De Leo, 2003; Eitzring, Block, & Funder, 2005; Huey & Weisz, 1997). On the contrary, lower levels of ego-resiliency were related to hard drug use (Block, Block, & Keyes, 1988), depressive symptoms (Block & Gjerde, 1990) and internalizing and externalizing problems in both clinical (Huey & Weisz, 1997) and nonclinical samples (Chuang, Lamb, & Hwang, 2006). In young adulthood, high levels of ego-resiliency were related to identity consolidation (Pals, 1999) and faster psychological and emotional recovery from stress (Tugade & Fredrickson, 2004). Finally, in later adulthood, ego-resiliency was linked to successful adjustment and life outcomes (Ong, Bergerman, Bisconti, & Wallace, 2006).

These results lead us to recognize ego-resiliency as one of the most important adaptive features of the personality, which effectively increase and strengthen resilience and ensure greater chances of success in the face of life's hardships and difficulties.

1.2. Ego-resiliency during emerging adulthood

Although the role of ego-resiliency in individuals' adaptation has been widely documented across different developmental phases (Block, Block & Keyes, 1988; Block & Gjerde, 1990; Chuang, Lamb & Hwang, 2006; Denissen, Asendorpf & van Aken, 2008; Eisenberg, Chang, Ma & Haug, 2009; Huey & Weisz, 1997; Ong, Bergherman, Bisconti & Wallace, 2006; Westenburg & Block, 1993), few investigators have directly addressed the factors that might foster or promote the development of ego-resiliency in late adolescence to emerging adulthood (see Hofer, Eisenberg, & Reiser, 2010, for findings in late high school).

The transition from adolescence to adulthood concerns a new developmental period for young people, lasting from late teens through the mid- to late twenties, and requires adjustment to many psychological and environmental changes (e.g., Arnett, 2000; Graber, Brooks-Gunn, & Petersen, 1996). Individuals become more independent and start to search for their place in society, according to social and normative roles expected for adults (Arnett, 2000). Unsurprisingly, such life transitions represent a time of particular vulnerability to stress (Compas, Wagner, Slavin, & Vannatta, 1986) because the advent of these experiences may disrupt the previous equilibrium of an adolescent's ecological system (Breunlin, 1988). As such, examining the internal resources youths have to psychologically cope with these changes and transitions is important in the prediction of their adjustment and well-being (Lazarus & Folkman, 1984).

During these years, individuals make life decisions that greatly impact their long-term adjustment: educational training, occupational decisions, marriage, starting a family. At the same time their personality characteristics are particularly sensitive to environmental influences (Sturaro, Denissen, van Aken & Asendorpf, 2008). Overall this is a time of increasing diversity in life paths (Schulenberg, Sameroff & Cicchetti, 2004), where there is an increase in individual differences regarding how this transition is faced. Therefore the years between adolescence and young adulthood are "an optimal window" for studying relations between personality and significant life outcomes (Krueger, 1999).

In this regard, resilient individuals are more likely to assume adult responsibilities such as leaving the parental house, finding a part-time job and committing to a romantic relationship at a younger age compared to overcontrolled and undercontrolled individuals (Denissen, Asendorpf & van Aken, 2008). It seems probable that resilient individuals continue to do well during the transition from late adolescence to early adulthood, whereas ego-brittle individuals might be required to revise the way they confront life, which in turn might impinge on their level of ego-resiliency (Arnett, 2000). Of interest, researchers have not found clear support for the existence of different ego-resiliency trajectories for males and females from adolescence to emerging adulthood (Chuang et al., 2006; Vecchione et al., 2010).

Given the variability in the pathways leading to adulthood, the flexibility of personality characteristics have a relevant role in marking future adjustment pathways. In particular, the transition to adulthood is a time in which depressive personality problems emerge, seriously compromising one's ability to make good personal choices that may jeopardize future adjustments in multiple domains such as interpersonal relationships (Tanner et al., 2007; Paradis, Reinherz, Giaconia, & Fitzmaurice, 2006), work productivity and educational outcomes (Wittchen, Nelson, & Lachner, 1998). Differently, during this phase there is an average reduction in antisocial problems that usually peak during adolescence. Therefore the presence of antisocial personality problems at this age may represent a severe impairment of future adaptation. (Roisman, Aguilar, & Egeland, 2004)

2. Outline of the Dissertation

The present work adopts the definition offered by Block and Kremen (1996) who identified ego-resiliency as trait resilience, that is, the individual ability to dynamically and appropriately self-regulate that allows high resilient people to adapt more quickly to changing circumstances. As argued by Waugh, Fredrickson and Taylor (2008), although most individuals may exhibit resilient behavior at one time or another, treating resilience as a trait accounts for significant individual

differences in the capacity to adapt in the face of trauma and stress. Within this framework, ego-resiliency is expected to reflect individual differences that may be present as early as at birth (Caspi et al., 2003).

The first research question is “If it is true that ego-resiliency plays a significant role in individuals’ adjustment, what are the antecedents sustaining this construct during emerging adulthood?” In particular, the present work attempts to identify the variables that sustain and support ego-resiliency over time, from adolescence to early adulthood. On the basis of this research question, assuming that ego-resiliency has a key role in individuals’ adjustment, this dissertation seeks to extend this assumption to a critical developmental period - the transition from late adolescence to emerging adulthood, a period of numerous changes and environmental demands. In other words, “Does ego-resiliency play an important role in predicting successful adaptation during young adulthood?”

From Chapters I to III, empirical findings derived from the Genzano longitudinal study will be discussed. Specifically, Chapter I aims to investigate the relation between positivity (a basic disposition that leads the individual to evaluate life and one’s experiences in a positive light, with an essentially biological value; Caprara et al., 2009) and ego-resiliency during the period from the beginning of adolescence to emerging adulthood (from 16 to 26 years) through a panel structural equation model. As there have been few studies that investigated the relation between these two personality traits, we propose to study this relation assuming that individuals who see the world and their experiences through a positive light tend to develop more strategies to improve their ego-resiliency and are thus able to effectively deal with the surrounding life experiences.

Chapter II aims to examine the reciprocal longitudinal relations between adolescents’ self-reported ego-resiliency and emotional self-efficacy beliefs in expressing positive emotions and in managing negative emotions as they move into early adulthood (from 16 to 26 years) by using a panel structural equation model. In spite of addressing different personality aspects, these constructs seem to be related to each other. In this regard, we hypothesized that perceiving oneself as able to

adapt successfully to changing and demanding circumstances might provide a suitable condition to strengthen the ability at the basis of emotional self-efficacy beliefs. At the same time, individuals' ability to manage negative emotions and appropriately express positive emotion may strengthen their self-report of ego-resiliency. The posited conceptual model has implications for interventions designed to promote and sustain ego-resiliency.

Chapter III aims to examine the influence of ego-resiliency on the development of determinant life outcomes such as internalizing and externalizing problems during the period from 20 to 29 years old. The present research contributes to the understanding of the role played by ego-resiliency in shaping psychological adjustment in early adulthood.

Please note that Chapters II is based on submitted article, while chapters I and III are based on unpublished articles. They can be read independently from each other.

3. Genzano longitudinal study

The participants of the following studies were part of an ongoing Italian longitudinal project that has been conducted by Caprara, Pastorelli and their colleagues. The longitudinal design involved four cohorts of children attending 3rd grade in an elementary school in Genzano (Rome) at the time of the first assessment. Cohort 1 began during the 1989-90 academic year, cohort 2 during the 1990-91 academic year, cohort 3 during the 1991-92 academic year, and cohort 4 during the 1993-94 academic year. About 400 participants were assessed annually till early adolescence, and assessed biannually during adolescence and young adulthood.

This project aimed to investigate the main determinants and pathways of successful development and maladjustment from childhood to early adulthood.

Participants were originally drawn from two public junior high schools in a community located near Rome. This sample represents a socioeconomic microcosm of the larger Italian society, composed of families of skilled workers, farmers, professionals, local merchants and service staff. In particular, 16.4% of families held professional or managerial positions, 40.9% were merchants or

employees in various types of business, 13.4% were skilled workers, 20.8% were unskilled workers, 7.1% were retired and 1.5% were unemployed. This occupational socioeconomic distribution matches the national profile (Istituto Italiano di Statistica, 2002). The family composition (type of family and number of children) also matches national data. Most participants were from intact families (90.5%).

For the present dissertation, as we can see in Table 1, we used three cohorts assessed longitudinally from age 16-17-18 to age 28-29-30.

In particular, for studies 1 and 2 in which we investigated the variables that supported and improved ego-resiliency, we used variables at Time 1 (age 16-17-18), Time 2 (age 18-19-20), Time 3 (age 20-21-22) and Time 4 (age 24-25-26) based on self-report.

For the third study in which we investigated the relation between ego-resiliency and behavioral problems, we used adolescent's self-report variables from Time 3 when adolescents were 20-21 years old to Time 5 when young adult were 28-29 years old.

Table 1. *General sample of the dissertation and specific samples considered across the studies*

	Time 1	Time 2	Time 3	Time 4	Time 5
<i>Year</i>	2000	2002	2004	2008	2012
Cohort 1	Age 16	Age 18	Age 20	Age 24	Age 28
Cohort 2	Age 17	Age 19	Age 21	Age 25	Age 29
Cohort 3	Age 18	Age 20	Age 22	Age 26	Age 30

Note: For Studies 1 and the Study 2 we used Time 1 to Time 4. For Study 3 we used Time 3 to Time 5.

References

- Arend, R., Gove, F. L., & Sroufe, L. A. (1979). Continuity of individual adaptation from infancy to kindergarten: A predictive study of ego-resiliency and curiosity in preschoolers. *Child Development, 950-959*. doi: 10.2307/1129319
- Arnett, J. J. (2000). Emerging adulthood: A theory of development from the late teens through the twenties. *American Psychologist, 55*, 469-480. doi: 10.1037/0003-066X.55.5.469
- Asendorpf, J. B., & van Aken, M. A. G. (1991). Correlates of the temporal consistency of personality patterns in childhood. *Journal of Personality, 59*, 689-703. doi: 10.1111/j.1467-6494.1991.tb00927.x
- Baltes, P. B., & Staudinger, U. M. (2000). Wisdom: A metaheuristic (pragmatic) to orchestrate mind and virtue toward excellence. *American Psychological Society, 55*, 122-136. doi: 10.1037/0003-066X.55.1.122
- Benard, B. (1991). Fostering resiliency in kids: Protective factors in the family, school and community. Portland (OR): Western Center for Drug-Free Schools and Communities.
- Block, J. H., & Block, J. (1980). The role of ego-control and ego-resiliency in the organization of behavior. In W.A. Collins (Ed.), *Minnesota symposia on child psychology*, Vol 13, pp. 39–101. Hillsdale, NJ: Erlbaum.
- Block, J., Block, J. H., & Keyes, S. (1988). Longitudinally foretelling drug usage in adolescence: Early childhood personality and environmental precursors. *Child development, 336-355*. doi: 10.2307/1130314
- Block, J. H., & Gjerde, P. F. (1990). Depressive symptoms in late adolescence: A longitudinal perspective on personality antecedents. In J. Rolf, A. S. Masten, D. Cicchetti, K. H. Nuechterlein & S. Weintraub (Eds.), *Risk and protective factors in the development of psychopathology*, pp. 334-360. New York: Cambridge University Press.
- Block, J. H., & Kremen, A. M. (1996). IQ and ego-resiliency: Conceptual and empirical connections and separateness. *Journal of Personality and Social Psychology, 70*, 349-361.

doi: 10.1006/jrpe.2001.2344

- Block, J. H., & Block, J. (2006). Venturing a 30-year longitudinal study. *American Psychologist*, 61, 315-327. doi: 10.1037/0003-066X.61.4.315
- Breunlin, D. C. (1988). Oscillation theory and family development. In C. Falicov (Ed.), *Family transition*, pp. 133-155. New York: The Guilford Press.
- Buss, D. M. (2000). The evolution of happiness. *American Psychologist*, 55(1), 15-23. doi: 10.1037/0003-066X.55.1.15
- Caspi, A., Sugden, K., Moffitt, T. E., Taylor, A., Craig, I. W., Harrington, H., ... & Poulton, R. (2003). Influence of life stress on depression: Moderation by a polymorphism in the 5-HTT gene. *Science Signaling*, 301(5631), 386. doi: 10.1126/science.1083968
- Caprara, M., Steca, P., & De Leo, G. (2003). La misura dell'ego-resiliency. *Ricerche di psicologia*, 26, 7-23.
- Caprara, G. V., Fagnani, C., Alessandri, G., Steca, P., Gigantesco, A., Cavalli Sforza, L. L., & Stazi, M. A. (2009). Human optimal functioning: The genetics of positive orientation towards self, life, and the future. *Behaviour Genetics*, 39, 277–284. doi: 10.1007/s10519-009-9279-7
- Chuang, S. S., Lamb, M. E., & Hwang, C. P. (2006). Personality development from childhood to adolescence: A longitudinal study of ego-control and ego-resiliency in Sweden. *Journal of Behavioral Development*, 30, 338-343. doi: 10.1177/0165025406072795
- Compas, B. E., Wagner, B. M., Slavin, L. A., & Vannatta, K. (1986). A prospective study of life events, social support, and psychological symptomatology during the transition from high school to college. *American Journal of Community Psychology*, 14, 241-257. doi: 10.1007/BF00911173
- Cramer, B. (2000). *Cosa diventeranno i nostri bambini?* Milano: Raffaello Cortina.
- Cramer, P., & Block, J. (1998). Preschool antecedents of defense mechanism use in young adults: A longitudinal study. *Journal of Personality and Social Psychology*, 74(1), 159. doi: 10.1037/0022-3514.74.1.159

- Denissen, J. J. A., Asendorpf J. B., & van Aken, M. A. G. (2008). Childhood personality predict long-term trajectories of shyness and aggressiveness in the context of demographic transitions in emerging adulthood. *Journal of Personality*, 76, 67-99. doi: 10.1111/j.1467-6494.2007.00480.x
- Diener, E. (2000). Subjective well-being: The science of happiness and a proposal for a national index. *American Psychologist*, 55(1), 34-43. doi: 10.1037/0003-066X.55.1.34
- Eisenberg, N., Chang, L., Ma, Y., & Huang, X. (2009). Relations of parenting style to Chinese children's effortful control, ego resilience, and maladjustment. *Development and Psychopathology*, 21(2), 455. doi: 10.1017/S095457940900025X
- Eisenberg, N., Valiente, C., Fabes, R. A., Smith, C. L., Reiser, M., Shepard, S. A., ... & Cumberland, A. J. (2003). The relations of effortful control and ego control to children's resiliency and social functioning. *Developmental Psychology*, 39(4), 761. doi: 10.1037/0012-1649.39.4.761
- Eisenberg, N., Spinrad, T. L., Fabes, R. A., Reiser, M., Cumberland, A., Shepard, S.A., ... Murphy B. (2004). The relations of effortful control and impulsivity to children's resiliency and adjustment. *Child Development*, 75, 25-46. doi: 10.1111/j.1467-8624.2004.00652.x
- Eitzring, T. D., Block, J. & Funder, D. C. (2005). Ego-control and ego-resiliency: Generalization of self-report scales based on personality descriptions from acquaintances, clinicians and the self. *Journal of Research in Personality*, 39, 395-422. doi: 10.1016/j.jrp.2004.06.003
- Funder, D. C., & Block, J. (1989). The role of ego-control, ego-resiliency, and IQ in delay of gratification in adolescence. *Journal of Personality and Social Psychology*, 57(6), 1041. doi: 10.1037/0022-3514.57.6.1041
- Garmezy, N. (1991). Resiliency and vulnerability to adverse developmental outcomes associated with poverty. *American Behavioral Scientist*, 34, 416-430. doi: 10.1177/0002764291034004003
- Graber, J. A., Brooks-Gunn, J., & Petersen, A. C. (1996). Adolescent transitions in context. In J. A. Graber, J., Brooks-Gunn, & A. C., Petersen, (Eds.), *Transitions through adolescence:*

Interpersonal domains and context, pp. 369-383. Mahwah, NJ: Erlbaum.

- Gjerde, P. F., Block, J., & Block, J. H. (1988). Depressive symptoms and personality during late adolescence: Gender differences in the externalization-internalization of symptom expression. *Journal of Abnormal Psychology, 97*(4), 475. doi: 10.1037/0021-843X.97.4.475
- Hofer, C., Eisenberg, N., & Reiser, M. (2010). The role of socialization, effortful control, and ego resiliency in French adolescents' social functioning. *Journal of Research on Adolescence, 20*(3), 555-582. doi: 10.1111/j.1532-7795.2010.00650.x
- Huey Jr, S. J., & Weisz, J. R. (1997). Ego control, ego resiliency, and the five-factor model as predictors of behavioral and emotional problems in clinic-referred children and adolescents. *Journal of Abnormal Psychology, 106*(3), 404. doi: 10.1037/0021-843X.106.3.404
- Istituto Italiano di Statistica (2002). *Annuario statistico italiano 2002 [Italian yearbook of statistics 2002]*. Rome: ISTAT.
- Klonhén, E. C. (1996). Conceptual analysis and measurement of the construct of ego-resiliency. *Journal of Personality and Social Psychology, 70*, 1067-1079. doi: 10.1037/0022-3514.70.5.1067
- Krueger, R. F. (1999). Personality traits in late adolescence predict mental disorders in early adulthood: A prospective-epidemiological study. *Journal of Personality, 67*, 39–65. doi: 10.1111/1467-6494.00047.
- Lazarus, R. S. & Folkman, S. (1984). *Stress, appraisal and coping*. New York: Springer.
- Luthar, S. S. (1991). Vulnerability and resilience: A study of high-risk adolescents. *Child Development, 62*, 600–616. DOI: 10.1111/j.1467-8624.1991.tb01555.x
- Masten, A. S., Best, K. M., & Garmezy, N. (1990). Resilience and development: Contribution from the study of children who overcome adversity. *Development and Psychopathology, 2*, 425-444. doi: 10.1017/S0954579400005812
- McCrae, R. R., & Costa Jr, P. T. (1999). A five-factor theory of personality. *Handbook of*

Personality: Theory and Research, 2, 139-153.

- Milgram, N. A., & Palti, G. (1993). Psychosocial characteristics of resilient children. *Journal of Research in Psychology*, 27, 207-221. doi: 10.1006/jrpe.1993.1015
- Mischel, W., Shoda, Y., & Peake, P. K. (1988). The nature of adolescent competencies predicted by preschool delay of gratification. *Journal of Personality and Social Psychology*, 54(4), 687. doi: 10.1037//0022-3514.54.4.687
- Myers, D. G. (2000). The funds, friend, and faith of happy people. *American Psychologist*, 55(1), 56-67. doi: 10.1037/0003-066X.55.1.56
- Ong, A. D., Bergeman, C. S., Bisconti, T. L., Wallace, K. A. (2006). Psychological resilience, positive emotions, and successful adaptation to stress in later life. *Journal of Personality and Social Psychology*, 91, 730-749. doi: 10.1037/0022-3514.91.4.730
- Pals, J. L. (1999). Identity consolidation in early adulthood: Relations with ego resiliency, the context of marriage, and personality change. *Journal of Personality*, 67, 295–329. doi: 10.1111/1467-6494.00057
- Paradis, A. D., Reinherz, H. Z., Giaconia, R. M., & Fitzmaurice, G. (2006). Major depression in the transition to adulthood: The impact of active and past depression on young adult functioning. *The Journal of Nervous and Mental Disease*, 194, 318-323. doi: 10.1097/01.nmd.0000217807.56978.5b.
- Peterson, C. (2000). The future of optimism. *American Psychologist*, 55, 44-55. doi: 10.1037/0003-066X.55.1.44
- Roisman, G. I., Aguilar, B., Egeland, B., (2004). Antisocial behavior in the transition to adulthood: The independent and interactive roles of developmental history and emerging developmental tasks. *Developmental and Psychopathology*, 16, 857-871. doi:10.1017/S0954579404040040
- Rutter, M. (1985). Resilience in the face of adversity: Protective factors and resistance to psychiatric disorder. *Britain Journal of Psychiatry*, 147, 598-611. doi:10.1192/bjp.147.6.598
- Rutter, M. (1990). Psychosocial resilience and protective mechanisms. In J. Rolf, A. S. Masten, D.

- Cicchetti, K. H. Nuechterlein & S. Weintraub (Eds.), *Risk and protective factors in the development of psychopathology*. Cambridge: University Press.
- Ryan, R. M., & Deci, E.L. (2000). Self-determination theory and the facilitation of intrinsic motivation, social development, and well-being. *American Psychologist*, 55, 68-78. doi: 10.1037/0003-066X.55.1.68
- Schulenberg, J. E., Sameroff, A. J., & Cicchetti, D. (2004). The transition to adulthood as a critical juncture in the course of psychopathology and mental health. *Development and Psychopathology*, 16(4), 799-806. doi: 10.1017/S0954579404040015
- Simonton, D. K. (2000). Creativity: Cognitive, personal, developmental, and social aspects. *American Psychologist*, 55(1), 151-158. doi: 10.1037/0003-066X.55.1.151
- Strayer, J., & Roberts, W. (1989). Children's empathy and role taking: Child and parental factors, and relations to prosocial behavior. *Journal of Applied Developmental Psychology*, 10(2), 227-239. doi: 10.1016/0193-3973(89)90006-3
- Sturaro, C., Denissen, J. J., van Aken, M. A., & Asendorpf, J. B. (2008). Person-environment transactions during emerging adulthood. *European Psychologist*, 13(1), 1-11. doi: 10.1027/1016-9040.13.1.1
- Tanner, J. L., Reinherz, H. Z., Beardslee, W. R., Fitzmaurice, G. M., Leis, J. A. & Berger, S. R. (2007). Change in prevalence of psychiatric disorders from ages 21 to 30 in a community sample, *Journal of Nervous and Mental Disease*, 195, 298-306. doi:10.1097/01.nmd.0000261952.13887.6e.
- Tugade, M. M., & Fredrickson, B. (2004). Resilient individuals use positive emotions to bounce back from negative emotional experience. *Journal of Personality and Social Psychology*, 86, 320-333. doi: 10.1037/0022-3514.86.2.320
- Vecchione, M., Alessandri, G., Barbaranelli, C., Gerbino, M. (2010). Stability and change of ego resiliency from late adolescence to young adulthood: A multiperspective study using the

ER89–R scale. *Journal of Personality Assessment*, 92, 1-10.
doi:10.1080/00223891003670166

Wagnild, G. M., & Young, H. M. (1993). Development and psychometric evaluation of the resilience scale. *Journal of Nursing Measurement*, 1(2), 165-178.

Waugh, C. E., Fredrickson, B. L., & Taylor, S. F. (2008). Adapting to life's slings and arrows: Individual differences in resilience when recovering from an anticipated threat. *Journal of Research in Personality*, 42(4), 1031-1046. doi: 10.1016/j.jrp.2008.02.005

Werner, E., & Smith, R. S. (1992). *Overcoming the odds: High risk children for birth to adulthood*. Ithaca, NY: Cornell University Press.

Westenberg, P. M., & Block, J. (1993). Ego development and individual differences in personality. *Journal of Personality and Social Psychology*, 65(4), 792. doi: 10.1037//0022-3514.65.4.792

Wittchen, H. U., Nelson, C. B., & Lachner G. (1998). Prevalence of mental disorders and psychosocial impairment in adolescents and young adults. *Psychological Medicine*, 28, 109-126. doi: 00006826-199801000-0001o

Wolfson, J., Fields, J. H., & Rose, S. A. (1987). Symptoms, temperament, resiliency, and control in anxiety-disordered preschool children. *Journal of the American Academy of Child & Adolescent Psychiatry*, 26(1), 16-22. doi: 10.1097/00004583-198701000-00004

CHAPTER I The role of Positivity as a predictor of Ego-resiliency

1. Introduction

In recent years, increased attention has been paid to the personal and environmental determinants of well-being and proper individual functioning in line with the theoretical and empirical growth of the Positive Psychology movement (Seligman & Csikszentmihalyi, 2000). In this regard, many researchers have focused on identifying appropriate indicators of individual differences in optimal functioning. In particular, researchers have investigated the presence of a general tendency to interpret events and one's life experience through a positive outlook.

For example, Scheier and Carver (1993) suggested the existence of a general disposition of personality called "positive thinking", the core of individuals' confidence in their future. Instead, Kozma, Stones and Stine (2000) described "positivity" as a general dispositional determinant of subjective well-being. Diener, Scollon, Oishi, Dzokoto and Suh (2000) described the positivity as a general tendency to evaluate, in a benign way, various aspects related to one's own experience in the world. Recently, Caprara and colleagues (Alessandri, Caprara, & Tisak, 2012; Caprara, Steca, Alessandri, Abela & McWhinnie, 2010) developed a research program that addressed positivity in

terms of what is common to self-esteem, optimism and life satisfaction. All three constructs correspond to an enduring global evaluation able to exert a pervasive influence on the different spheres of individual functioning such as the affective, cognitive, and behavioral. The three dimensions probably reflect a common way of thinking and a vision of existence that are particularly functional for people's well-being. In fact, these constructs have been highly correlated to each other and with a number of outcomes that reflect individual well-functioning such as health, job success and positive interpersonal relationships (Baumeister, Campbell, Krueger, & Vohs, 2003; Lyubomirsky, King, & Diener, 2005; Scheier, Carter & Bridges, 1994).

In this study we examine the relation between this construct, Positivity, and ego-resiliency, a personality trait highly associated with individual general adjustment, as previously mentioned. Ego-resiliency represents an intermediate level, reflecting the general capacity for flexible and resourceful adaptation to varying external environmental circumstances and to internal dysphoric states (Block & Block, 1980; Block & Kremen, 1996). In particular we review the relevance of the predictive role of positivity on the development of ego-resiliency during a period of ten years, from adolescence to early adulthood (from 16 to 26 years old).

2. Positivity (POS)

Earlier studies have led to the identification of a common latent factor between self-esteem, optimism and life satisfaction, termed positive thinking (Caprara & Steca, 2005; 2006), positive orientation (Alessandri et al., 2010; Caprara et al., 2009, 2010), or positivity (POS), corresponding to a quite pervasive mode of viewing and facing reality that affects the way people evaluate their subjective experiences (Alessandri et al., 2010; Caprara et al., 2010).

Positivity is a basic mode through which individuals face the reality. It can determine the quality of one's subjective experience in the world (Caprara et al, 2010). This orientation can be seen as a positive lens through which to view the world and one's life; there isn't reference to

personal characteristics of positivity but rather to the cognitive mode adopted in the evaluation of one's life (Alessandri, Caprara & Tisak, 2012; Caprara, Alessandri, Barbaranelli, 2010).

Findings from twin studies (Caprara, et al. 2009) have converged with longitudinal and cross-sectional data in attesting to the trait-like nature of POS and its stability (Alessandri, et al., 2012). Cross-cultural studies have documented the generalizability of POS factorial structure across countries that differ widely in terms of cultural models of self, language, cultural and historical roots and ways of life (Caprara, et al., 2012). Longitudinal study has further attested to the trait-like nature of positive orientation and to its impact on individuals' psychosocial well-being, showing strong and positive associations with health, quality of friendships, positive affectivity, and ego-resiliency (Alessandri, et al., 2012).

On the basis of these results, Caprara and colleagues (2009) defined Positivity as a stable individual tendency to viewing oneself, life, and the future under a positive outlook (Alessandri, Caprara, & Tisak, 2012; Caprara et al., 2009). Theoretically, it has been proposed that positivity exerts an important adaptive function by promoting more effective coping in spite of adversities, failures or loss (Caprara, et al., 2009). As postulated by the Conservation of Resource (COR) model (Hobfoll, 1989; 1998), positivity leads individuals to perceive events as predictable and generally occurring in one's best interest (Antonovsky, 1979; see also Hobfoll, 1989, p. 517). Moreover it is theorized that positivity is the *key* resource in buffering the negative effects of stressors and unexpected life events on later adjustment and well-being (Hobfoll, 1989).

This construct may be associated with what many authors call Positivity Bias, which is the tendency to see oneself and the environment through a positive image (Heider, 1958). Many authors suggested that this bias is an adaptive feature of human cognition that is consistently associated with mental and physical health (Lee & Seligman, 1997; Peterson, Seligman & Vaillant, 1988). Some studies have also indicated that children show a broad positivity bias compared with other age groups. These cognitions are high in early childhood, but decline with age (Jacobs, Lanza, Osgood, Eccles, & Wigfield, 2002). This decline is associated with both motivational factors through which

children maintain high self-esteem (Ruble, Eisenberg, & Higgins, 1994) and factors related to cognitive development (Schuster, Ruble & Weinert, 1998). However, the greatest decline occurs in adolescence, particularly during the transition from primary to middle and high school, which represents a highly stressful transition associated with the decline of self-esteem and one's belief in his or her competence (Fenzel, 2000; Hankin et al, 1998).

In contrast to the developmental trend of positivity bias, positivity seems to be stable over time. Previous studies suggested that POS would represent a solid, enduring individual characteristic that slowly changes under various environmental pressures (Alessandri et al., 2012; Caprara, Alessandri, et al., 2010; Caprara, Steca, et al., 2010). In addition, genetic studies demonstrated that individuals' scores on POS would have little or no change and would maintain rank order stability across time (Caprara et al, 2009; Fagnani et al, 2010).

3. Relation between positivity and ego-resiliency

Like a basic characteristic of human nature, it is possible that POS develops early in infancy as a basic appraisal and evaluative system and then stably shapes the way the individual categorizes his own experiences in the world at a later age. However, few studies have considered Positivity as a predictor of ego-resiliency. Some studies attested a strong link between these two constructs using cross-sectional samples (Alessandri et al, 2012; Caprara, Alessandri et al, 2010; Caprara, Steca et al, 2010).

Only one study examined the relation between the two constructs using longitudinal data. In their study, Alessandri, Caprara & Tisak (2012) founded that POS predicted positive and negative affectivity, quality of interpersonal relationships and psychological resilience across time, and that positivity explained about the 35% of trait variance in psychological resilience with the remaining proportions attributable to environmental experiences (25%) and to unspecified factors and measurement error (40%). These findings assigned POS an eminent role as a “dispositional” cause that promotes and sustains ego-resiliency and successful adaptation.

With regard to the relation between ego-resiliency and the dimensions of positivity (self-esteem, optimism, life satisfaction), there was also a paucity of studies.

In particular, research has focused on the relation between optimism and ego-resiliency, supporting optimism as a factor that contributes to ego-resiliency and identifying it as the most influential adolescent cognitive factor to moderate the effects of life stressors (Tusaie-Mumford, 2001; Hauser, 1999; Gordon & Song, 1994; Werner & Smith, 1992). Yu and Zhang (2007) argued that optimism reflects individuals' positive attitude toward adverse situations and therefore considered optimism as an important consequence of ego-resiliency. Studies of Carver, Scheier, and Segerstrom (2010), Tusaie-Mumford (2001) and Bonanno (2005) further supported the view that ego-resiliency and optimism might be reciprocally related, since they seemed to accompany each other in stressful situations. Based on previous research, therefore it seems likely that positivity might provide the motivation to use regulatory abilities in the service of ego-resiliency.

4. The present study

In this study we tested hypotheses on the associations of POS with youths' development. In particular, we hypothesized that the development of ego-resiliency may be predicted by the development of positivity. This hypothesis was based on both previous results attesting the strong links between these two constructs in cross-sectional samples (Alessandri et al., 2012; Caprara, Alessandri, et al., 2010; Caprara, Steca, et al., 2010) and the genetic basis of positivity. We tested this hypothesis using a dynamic (i.e., longitudinal) rather than a static (i.e., cross-sectional) model, through a autoregressive cross-lagged regression model in which the stability of constructs was taken into account to better assess potential causal relations. The expected direction of the effects is displayed in Figure 1. However, we did not exclude the possibility that the experience of being regulated and flexible might contribute to positivity. Therefore, in exploratory analyses, we also tested whether ego-resiliency was as significant predictor of later positivity. It seemed possible that,

over time, perceiving oneself as successful in dealing with stressors and taxing environmental circumstances could lead to view through a positive light the life and the surrounding world.

In addition, in this study we considered a 10-year life span from the beginning of adolescence to emerging adulthood (from 16 to 26 years old). We considered this period because it is well known that during the transition from adolescence to emerging adulthood, personality characteristics can be particularly susceptible to modification. As Arnett (2000) pointed out, at the end of adolescence boys and girls engage in novel experiences in exploration of the educational and job worlds, as well as in interpersonal and intimate relationships, and live a series of “microtransitions” (Breunlin, 1988) that are highly diversified across individuals. Thus, we reasoned that the transition from late adolescence to emerging adulthood would represent a strong “test bench” for the role played by the positivity and ego-resiliency.

5. Method

5.1. Participants

The participants were part of an ongoing Italian longitudinal project conducted by Caprara, Pastorelli and their colleagues (Caprara et al., 1998, 2005; Pastorelli et al., 2001) since the late 80’s, with the aim of investigating the main determinants and pathways of successful development and maladjustment from childhood to early adulthood.

The participants were 373 adolescents, 198 females and 175 males, aged from 16 to 18 years at Time 1 (henceforth labelled T1; *mean* age = 16.91, *SD* = .99), from 18 to 20 years at Time 2 (T2; *mean* age = 18.88, *SD* = .99), from 20 to 22 years at Time 3 (T3; *mean* age = 20.86, *SD* = 1.02), and from 24 to 26 years at Time 4 (T4; *mean* age = 24.93, *SD* = 1.18). Most participants were attending high school at T1 and T2 (from 16 to 20 years). At T3 and T4, approximately half (52.7% at T3 and 49% at T4) were college students.

5.1.1. Attrition and missing data analysis

Data was available for 337 individuals at Time 2, 252 at Time 3 and 161 individuals at Time 4. Overall, 43.16 % of the original sample remained and contributed data at the final assessment time (2008). The attrition was mainly due to the individuals' inavailability to take part in this phase of the study. In some cases, the participants were uncontactable. Analyses of variance suggested that the participants included in the final sample at the later assessment (Time 4) did not significantly differ from their counterparts (participants not included in the final Time) on the means and the covariances of the examined variables as tested by a multivariate analysis of variance and *Box-M* test for homogeneity of covariance matrices. In sum, the attrition did not seem to be systematic.

The lack of selective attrition in our data is supported by Little's test (Little & Rubin, 2002) for data missing completely at random (MCAR) as implemented in SPSS 14. This test resulted in a non-significant value (i.e., $\chi^2 = 153.467$, $df = 138$; $p = .17$), indicating that missingness was related to the observed values of the variables in the data set, but unrelated to unobserved missing values (Enders, 2010). Accordingly, we computed the maximum-likelihood estimates of missing data via the expectation-maximization (EM) algorithm that restores the complete data matrix and offers unbiased estimates of missing data under MCAR assumption (Enders, 2010). The final sample size for this study was 273 (175 males and 198 females).

5.2. Procedure

The young adults enrolled in this study were invited to participate in the study by phone. Questionnaires and consent forms were sent to the participants by mail. All the envelopes were returned directly by the participants to a team of two or three researchers during specifically scheduled meetings in a school. The participants received a small payment for their participation at Time 1 and Time 2 (25 Euros or an equivalent dinner token). At Time 3, participants did not receive any payment.

Figure 1. Conceptual Model of the Paths of Influence of Individual's Ego-Resiliency and Positivity Assessed at T1, at T2, at T3 and T4. POS = positivity; RES = Ego-resiliency

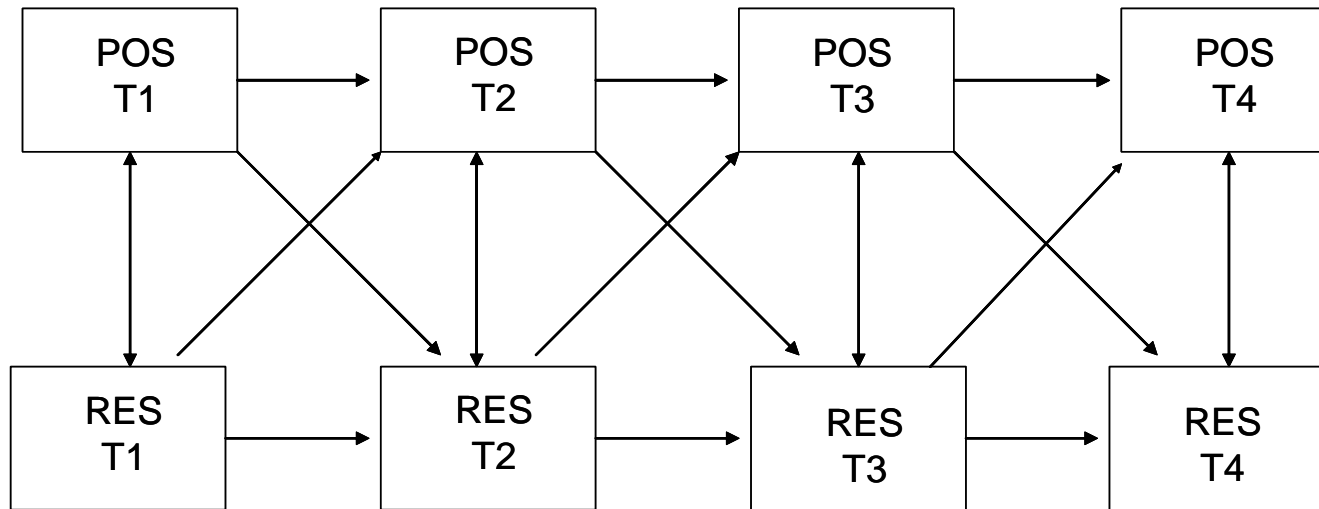

5.3. Measures

The measures were all self-report scales and included measures of ego-resiliency and the latent factor of Positivity administered at each time point.

Ego-resiliency. The ER89–R (Alessandri et al., 2008; Vecchione, et al. 2010) is a brief inventory composed of 10 items. Participants were asked to indicate the degree to which they agreed with each statement on a scale ranging from 1 (does not apply at all) to 4 (applies very strongly). High correlations with the original measure devised by Block and Kremen (1996) have confirmed the construct validity of the scale (Alessandri et al., 2008; Vecchione, et al. 2010). The psychometric properties of the instrument have been documented in a large sample of Italian respondents (Alessandri et al., 2008) and confirmed in both cross-cultural and longitudinal research (Alessandri, Vecchione, Letziring, & Caprara, 2012; Vecchione et al., 2010). Sample items include “I quickly get over and recover from being startled,” and “I get over my anger at someone reasonably quickly” (alphas = .84, .84, .85, and .83 from T1 to T4, respectively).

Positivity. As for earlier studies, we estimated the individuals’ scores on the latent POS construct using explorative factor analysis. Specifically, the measures of self-esteem, life satisfaction, and optimism were factor analyzed (with principal axis factor analysis), and an estimated factor score was obtained for all participants from the one-factor solution. At all time, indices of fit for this analysis revealed only one eigenvalue higher than 1 (2.014, 2.183, 2.277, and 2.233, from T1 to T4 respectively; 67% for T1, 73% for T2, 76% for T3 and 74% for T4 of variance explained by the one-factor solution). The factor scores for all times were saved and inserted into the SPSS data file which included the other variables investigated (e.g. demographic variables and ego-resiliency), so that this new variable could be used for subsequent analyses.

5.4. Statistical Analyses

To estimate the hypothesized model and handle missing data, we used *Mplus* 5.01 (Muthén & Muthén, 2006) with Full Information Maximum Likelihood (FIML) estimation. Compared to

other methods for handling missing data, such as listwise or pairwise deletion, FIML produces more reliable estimates for parameters and model fit (Enders & Bandalos, 2001).

To evaluate model fit for autoregressive cross-lagged models, the following criteria were employed: χ^2 likelihood ratio statistic, Tucker and Lewis Index (*TLI*), Comparative Fit Index (*CFI*), and the Root Mean Square Error of Approximation (*RMSEA*) with associated confidence intervals. The significance value of chi-square is sensitive to large sample sizes and easily produces a statistically significant result (Kline, 1998). We accepted *TLI* and *CFI* values greater than or equal to .95 (Hu & Bentler, 1999) and *RMSEA* values lower than or equal to .06 (Browne & Cudeck, 1993). To test for differences in fit among nested models, we calculated the chi-square difference test ($\Delta\chi^2$; see Bollen, 1989). The autoregressive cross-lagged models were conducted within multigroup analyses by sex.

6. Results

Using one-way analyses of variance (ANOVA), we first examined sex differences in the measures within each of the four time points. Next, we examined the zero-order correlations among the variables, both within time and across time. Third, we used structural equation modeling for testing the aforementioned hypotheses.

6.1 Descriptive Statistics

Table 1 presents the means and standard deviations of ego-resiliency and positivity at T1, T2, T3 and T4. One-way analyses of variance indicated that there were significant gender differences for positivity only at T2 and T3 (from 20 to 24 years old). Males were more positive than females during the transition from adolescence to adulthood.

Table 2 presents the zero-order correlations among observed variables (i.e., ego-resiliency, and positivity). As expected, ego-resiliency and positivity were positively and significantly related, both concurrently and across time. Also, examined variables proved to be highly stable over time.

Table 1. Mean, Standard Deviation, and Sex Differences for Ego-Resiliency and Positivity at each of the four Assessments for Males and Females

Variable	Males		Females		Sex	
	M	SD	M	SD	F (1, 373)	Sign.
Ego-resiliency T1	4.91	.80	5.03	.75	2.18	.140
Positivity T1	0.09	.90	-0.08	1.07	2.86	.091
Ego-resiliency T2	4.91	.71	5.05	.74	3.52	.061
Positivity T2	0.11	.92	-.10	1.06	4.13*	.043
Ego-resiliency T3	5.00	.65	5.06	.72	0.73	.393
Positivity T3	0.11	.89	-.10	1.07	4.22*	.041
Ego-resiliency T4	5.07	.56	5.14	.64	1.06	.305
Positivity T4	0.01	.93	-.01	1.06	0.20	.887

Note. * $p < .05$. T1 = variable assessed at Time 1; T2 = variable assessed at Time 2; T3 = variable assessed at Time 3; T4 = variable assessed at Time 4. F = F ratio resulting from one-way analyses of variance; the degrees of freedom and the number of participants are within the parentheses.

Table 2. Zero-order Correlations among Measures of Ego-Resiliency and Positivity for Males and Females.

	1	2	3	4	5	6	7	8
1. Ego-res T1	1	.45**	.60**	.34**	.38**	.24**	.37**	.23**
2. Pos T1	.59**	1	.38**	.75**	.27**	.65**	.33**	.59**
3. Ego-res T2	.59**	.46**	1	.49**	.62**	.31**	.56**	.35**
4. Pos T2	.34**	.65**	.52**	1	.36**	.72**	.38**	.66**
5. Ego-res T3	.58**	.45**	.59**	.33**	1	.43**	.70**	.43**
6. Pos T3	.37**	.59**	.46**	.57**	.50**	1	-.52**	.70**
7. Ego-res T4	.52**	.41**	.52**	.41**	.54**	.35**	1	.50**
8. Pos T4	.42**	.63**	.38**	.59**	.50**	.71**	.50**	1

Note. The correlation coefficients below the diagonal are for males; the correlation coefficients above the diagonal are for females; T1 = variable assessed at Time 1; T2 = variable assessed at Time 2; T3 = variable assessed at Time 3; T4 = variable assessed at Time 4. Ego-res = Ego-Resilience; POS = Positivity ** $p < .0$

6.2. Modeling Strategies

We tested our theoretical model using an autoregressive cross-lagged model, following the suggestions of Cole and Maxwell (2003; Maxwell and Cole, 2007). In particular, we estimated a model that included (a) all the autoregressive paths (i.e., the paths predicting a variable from its prior level), as well as (b) the across-time paths from ego-resiliency at a given time point to positivity at the subsequent time point; and from positivity at a given time point to ego-resiliency at the subsequent time point; (c) all correlations between variables within time.

To estimate the hypothesized model, we used *Mplus* 5.01 (Muthén & Muthén, 2006). Missing data were handled by using Full Information Maximum Likelihood Estimation (*FIML*). This estimator maximizes the number of participants whose data contributes to the covariance matrix to be analyzed. Compared to other methods for handling missing data, *FIML* produces more reliable estimates for parameters and goodness of fit indices (Enders & Bandalos, 2001). According to a multifaceted approach to the assessment of model fit (Tanaka, 1993), the following criteria were employed to evaluate the goodness of tested models: χ^2 likelihood ratio statistic, Tucker and Lewis Index (*TLI*), Comparative Fit Index (*CFI*), and the Root Mean Square Error of Approximation (*RMSEA*) with associated confidence intervals. The significance value of chi-square is sensitive to large sample sizes and easily produces a statistically significant result (Kline, 1998). We accepted *TLI* and *CFI* values greater than .95 (Hu & Bentler, 1999) and *RMSEA* values lower than .06 (Browne & Cudeck, 1993).

To test the possible moderating effects of sex, we used multiple-group structural equation modeling (Muthén & Muthén, 2006). In our approach, the equivalence between male and female groups was evaluated by imposing identical unstandardized estimates for autoregressive and cross-lagged paths (we refer to this model as the *sex-constrained model*). The plausibility of these equality constraints was examined with the modification indices and the χ^2 difference test between nested models (i.e., the sex constrained model vs. the unconstrained model; see Bollen, 1989). We used the same procedure to constrain autoregressive and cross-lagged paths to be equal across time.

In this model (i.e., the *sex-time constrained model*), equality constraints were simultaneously applied across sex and across time.

6.3. Longitudinal Modeling Analyses

The *sex constrained model* showed a good fit to the data: $\chi^2(39) = 99.029$, $p = <.01$, $CFI = .941$, $TLI = .918$, $RMSEA = .091$ (.069 - .113). Following standard procedures, we examined the gain in fit achieved by freely estimating all paths across sexes. The change in fit between the *sex constrained model* versus the *unconstrained model* was not significant: $\Delta\chi^2(15) = 13.258$, $p = .58$, supporting the tenability of the constraints imposed across male and female groups. We then estimated the *sex-time constrained model* by further imposing equality constraints across time. This model fitted the data well $\chi^2(49) = 111.836$, $p < .00$, $CFI = .938$, $TLI = .932$, $RMSEA = .083$ (.063 - .103). Furthermore, the change in fit between the *sex-time constrained model* versus the *unconstrained model* was not significant: $\Delta\chi^2(25) = 26.065$, $p = .40$. This best-fit model is illustrated in Figure 2.

6.4. Autoregressive and Cross-lagged Path and Concurrent relations

As can be observed, all the autoregressive paths were significant. All the examined variables at T1 significantly predicted the same variables at T2, and so on for the subsequent time points, demonstrating a high degree of stability over time. In addition, positivity significantly predicted ego-resiliency from T1 to T2, from T2 to T3, and from T3 to T4. This prediction was not true from ego-resiliency to positivity for all the time points. All of these longitudinal predictions held above and beyond the stability of the variables. This result suggests that positivity can be an antecedent of ego-resiliency during an important development period, from adolescence to emerging adulthood. In addition these two variables seem to be closely related within time.

Figure 2. Longitudinal relations between individuals' Ego-Resiliency and Positivity assessed at T1, at T2, at T3 and T4 in the *sex-time constrained model*.

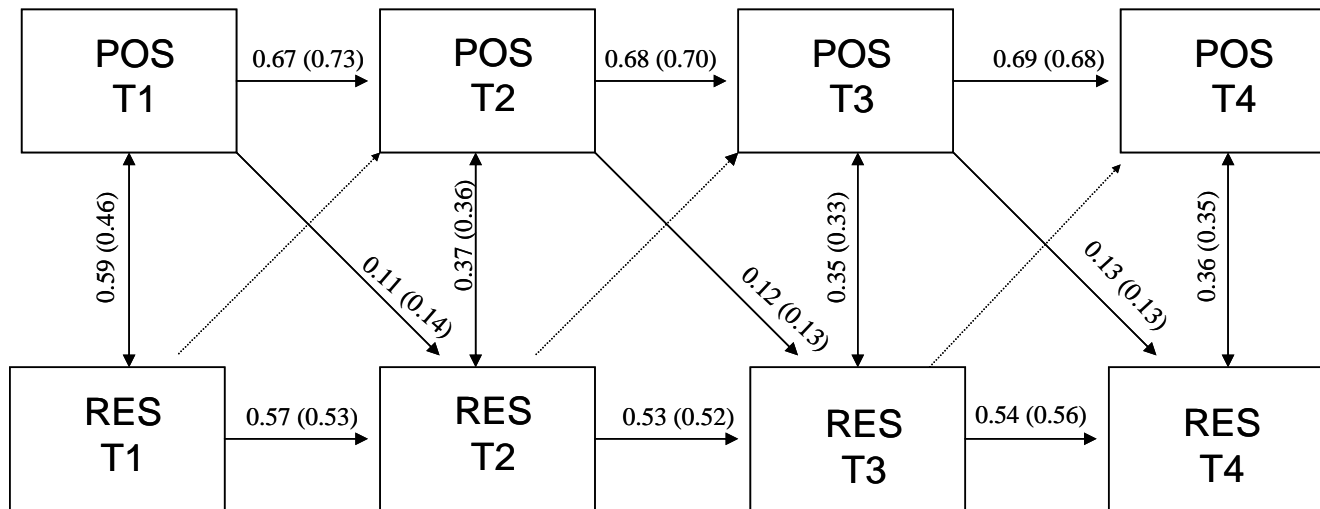

Note. Solid lines represent significant paths, dashed lines represent non-significant path. Reported coefficients refer to standardized estimates for males and for females (in parentheses) respectively. All parameters are significant beyond $p < .05$.

6.5. Explained variance

The model accounted for a large proportion of variability for all variables, with little differences across males and females. Specifically, for males, R-squared at T2 were 46% for positivity and 41% for ego-resiliency; at T3, they were 47% for positivity and 37% for ego-resiliency; at T4, they were 48% for positivity and 37% for ego-resiliency. For females, R-squared at T2 were 55% for positivity and 37% for ego-resiliency; at T3, they were 50% for positivity and 35% for ego-resiliency; at T4, they were 47% for positivity and 40% for ego-resiliency

7. Discussion

Little research has focused on the relation of ego-resiliency with other personality variables over the course of development. Findings from this study have several important practical implications because of their theoretical relevance to broaden the field of positive psychology. Indeed, our results shed light on the role of positivity and its associations with individuals' ego-resiliency during the transition from adolescence to emerging adulthood and represent an important contribution to the design of applied interventions aimed at fostering the development of resilience in youths.

As expected, results from the structural equation model demonstrated that these constructs were positively correlated within time. As it stands, despite high stability across time for all two constructs, we were able to confirm our expectation, based on previous studies, of a significant prediction of ego-resiliency from positivity over time, and not the contrary. As revealed by previous studies (Alessandri, Caprara & Tisak, 2012) POS accounted for a considerable proportion of trait variance (rather than state or error variance) of ego-resiliency. These findings are consistent with prior research indicating that positivity operates as a basic trait associated with the individuals' ability to effectively deal with internal affective states and to actively shape their life (Alessandri, et al 2012; Caprara, et al. 2010). Although there has been little literature investigating the role of positivity on ego-resiliency, present findings clearly attest to the strong associations of POS with

adolescents' adjustment and their ability to cope with changing and demanding environments, in particular during a transitional period associated with a multitude of challenges and tasks (moving from college to University, getting married, starting work, etc.).

Viewing positivity as a predisposition that enhances the effects of ego-resiliency opens new avenues to both research and practice concerned with promoting human potentials for adaptability. This finding also suggest that the construct of ego-resiliency may be particularly important during the transition to emerging adulthood when both social and interpersonal environments are likely to change. One possibility is that since late adolescents are required to efficaciously adapt to a rapidly changing environment, then their abilities to deal with stress, negative internal states and taxing social interactions could be of special importance.

In spite of the results of this work we cannot exclude the possibility of a reciprocal relation between positivity and ego-resilience in other developmental phases, as they seem to accompany each other during the development process, particularly during stressful life situations. Anyway, it seems likely that the pattern of relations identified in this study can be attributed to the specific time frame investigated. In sum, we prefer to be cautious in interpreting this effect and to reiterate the need for replication in studies covering larger time span. The idea that the relations between positivity and ego-resiliency may became reciprocals, and that ego-resiliency may drive the development of positivity is in fact attractive, and may represent an useful addendum to the agenda of future research in this area.

Marginally, we have to underline the gender differences emerged in the present study. In accord with literature (Alessandri et al, 2010; Caprara et al, 2009), males were more positive than females, especially during adolescence (from 16 to 20 years old). However, we found no differences in model parameters and the longitudinal relations observed among these constructs.

Based on these results, one could speculate that positivity would represent some sort of inherited psychological system that acts by orienting the daily interaction of individuals to the

surrounding environment. One may wonder about the extent to which and how any change can be pursued to promote a mode of viewing that significantly affects people's experience.

A few limitations of the current study should be noted. First, it would be desirable to test the generalizability of our findings across different populations and cultural contexts. The concepts of ego-resiliency and positivity may show important variations across social contexts and cultures (Mesquita & Frijda, 1992). Second, all variables were assessed using self-report measures. Whereas self-esteem, life satisfaction, optimism and ego-resiliency are private subjective evaluations that are necessarily accessible through self-report of individuals, future research would benefit from assessing constructs using multiple methods (i.e., clinical interviews, information processing tasks, etc.) and informants (i.e., parents and peers). Finally further research is needed to clarify the influence of life experiences on these two constructs.

Despite these limitations, the present study expanded research that has addressed the promotion of ego-resiliency and psychosocial adjustment over the transition to emerging adulthood.

References

- Alessandri, G., Vecchio, G., Steca, P., Caprara, M. G., & Caprara, G.V. (2008). A revised version of Kremen and Block's ego-resiliency scale in an Italian Sample. *Testing, Psychometrics, Methodology in Applied Psychology*, 14, 1-19. doi: 10.1027/1015-5759/a000102
- Alessandri, G., Vecchione, M., Letziring, T., Caprara, G.V. (2012). The ego-resiliency scale revised: A cross-cultural study in Italy, Spain, and the United States. *European Journal of Psychological Assessment*, 28, 139-146. doi: 10.1027/1015-5759/a000102
- Alessandri, G., Caprara, G. V., & Tisak, J. (2012). The unique contribution of positive orientation to optimal functioning: Further exploration. *European Psychologist*, 17, 44–45. doi: 1027/1016-9040/a000070
- Antonovsky, A. (1979). *Health, Stress and Coping*. San Francisco: Jossey-Bass.
- Arnett, J. J. (2000). Emerging adulthood: A theory of development from the late teens through the twenties. *American Psychologist*, 55, 469-480. doi: 10.1037/0003-066X.55.5.469
- Bandura, A. (1999). Exercise of agency in personal and social change. In E. Sanavio (Ed.), *Behavior and cognitive therapy today: Essays in honor of hans J. Eysenck*, (pp. 1-29). Oxford: Anonima Romana
- Baumeister, R. F., Campbell, J. D., Krueger, J. I., & Vohs, K. D. (2003). Does high self-esteem cause better performance, interpersonal success, happiness, or healthier lifestyle? *Psychological Science in the Public Interest*, 4, 1–44. doi: 10.1111/1529-1006.01431
- Block, J. H., & Block, J. (1980). The role of ego-control and ego-resiliency in the organization of behavior. In W.A. Collins (Ed.), *Minnesota symposia on child psychology*, Vol 13, pp. 39–101. Hillsdale, NJ: Erlbaum.
- Block, J. H., & Kremen, A. M. (1996). IQ and ego-resiliency: Conceptual and empirical connections and separateness. *Journal of Personality and Social Psychology*, 70, 349-361. doi: 10.1006/jrpe.2001.2344
- Bollen, K. A. (1989). *Structural-equations with latent variables*. New York: Wiley.

- Bonanno, G. A. (2005). Resilience in the face of potential trauma. *Current Directions in Psychological Science*, 14, 135–138. doi: 10.1111/j.0963-7214.2005.00347.x
- Breunlin, D. C. (1988). Oscillation theory and family development. In C. Falicov (Ed.) *Family Transition*, pp. 133-155. New York: The Guilford Press.
- Browne, M.W. & Cudeck, R. (1993). Alternative ways of assessing model fit. In K.A. Bollen, & S.J. Long (eds). *Testing structural equation models*, pp. 137-162. Newbery Park: Sage.
- Caprara, G. V., & Steca, P. (2005). Affective and social self-regulatory efficacy beliefs as determinants of positive thinking and happiness. *European Psychologist*, 10(4), 275. doi:10.1027/1016-9040.10.4.275
- Caprara, G. V., & Steca, P. (2006). The contribution of self-regulatory efficacy beliefs in managing affect and family relationships to positive thinking and hedonic balance. *Journal of Social and Clinical Psychology*, 25(6), 603-627. doi: 10.1521/jscp.2006.25.6.603
- Caprara, G. V., Fagnani, C., Alessandri, G., Steca, P., Gigantesco, A., Cavalli Sforza, L. L., & Stazi, M. A. (2009). Human optimal functioning: The genetics of positive orientation towards self, life, and the future. *Behaviour Genetics*, 39, 277–284. doi: 10.1007/s10519-009-9267-y
- Caprara, G. V., Steca, P., Alessandri, G., Abela, J. R. Z., & McWhinnie, C. M. (2010). Positive orientation: Explorations on what is common to life satisfaction, self-esteem, and optimism. *Epidemiologia e Psichiatria Sociale*, 18, 63–71. doi: 10.1017/S1121189X00001615
- Caprara, G. V., Alessandri, G., & Barbaranelli, C. (2010). Optimal functioning: The contribution of self efficacy beliefs to positive orientation. *Psychotherapy and Psychosomatics*, 79, 328–330. doi: 10.1159/000319532
- Caprara, G. V., Alessandri, G., Trommsdorff, G., Heikamp, T., Yamaguchi, S., & Suzuki, F. (2012). Positive orientation across countries. *Journal of Cross Cultural Psychology*, 43, 77–83. doi:10.1177/0022022111422257
- Carver, C. S., Scheier, M. F., & Segerstrom, S. C. (2010). Optimism. *Clinical Psychology Review*, 30, 879-889. doi: 10.1016/j.cpr.2010.01.006

- Cole, D. A., & Maxwell, S. E. (2003). Testing mediational models with longitudinal data: Questions and tips in the use of structural equation modeling. *Journal of Abnormal Psychology, 112*, 558–577. doi: 10.1037/0021-843X.112.4.558
- Diener, E., Scollon, C. K. N., Oishi, S., Dzokoto, V., & Suh, E. M. (2000). Positivity and the construction of life satisfaction judgments: Global happiness is not the sum of its part. *Journal of Happiness Studies, 1*, 159–176. doi: 10.1023/A:1010031813405
- Enders, C. K. (2010). *Applied missing data analysis*. Guilford Press.
- Enders, C. K., & Bandalos, D. L. (2001). The relative performance of full information maximum likelihood estimation for missing data in structural equation modeling. *Structural Equation Modelling, 8*, 430-457. doi: 10.1207/S15328007SEM0803
- Fagnani, C., Fibiger, S., Skytthe, A., & Hjelmberg, J. V. B. (2011). Heritability and environmental effects for self-reported periods with stuttering: A twin study from Denmark. *Logopedics Phoniatrics Vocology, 36*, 114–120. doi: 10.3109/14015439.2010.534503
- Fenzel, L. M. (2000). Prospective study of changes in global self-worth and strain during the transition to middle school. *The Journal of Early Adolescence, 20*(1), 93-116. doi: 10.1177/0272431600020001005
- Gordon, E. W. & Song, L. D. (1994). Variations in the experience of resilience. In M. C. Wang & E. W. Gordon (Eds.), *Educational resilience: Challenges and prospects*, pp.27-44. Mahwah, NJ: Lawrence Erlbaum Publishers.
- Hankin, B. L., Abramson, L. Y., Moffitt, T. E., Silva, P. A., McGee, R., Angell, K. E. (1998). Development of depression from preadolescence to young adulthood: Emerging gender differences in a 10-year longitudinal study. *Journal of Abnormal psychology, 107*, 128-140.
- Hauser, M. D. (1999). Perseveration, inhibition and the prefrontal cortex: A new look. *Current Opinion in Neurobiology, 9*, 214 –222. doi: 10.1016/S0959-4388(99)80030-0
- Heider, F. (1958). *The psychology of interpersonal relations*. New York: Wiley.

- Hobfoll, S. E. (1989). Conservation of resources: A new attempt at conceptualizing stress. *American Psychologist*, 44(3), 513–524. doi: 10.1037/0003-066X.44.3.513
- Hobfoll, S. E. (1998). *Stress, culture, and community: The psychology and philosophy of stress*. New York: Plenum Press.
- Hu, L., & Bentler, P. M. (1999). Cutoff criteria for fit indexes in covariance structure analysis: Conventional criteria versus new alternatives. *Structural Equation Modeling*, 6, 1-55. doi: 10.1080/10705519909540118
- Kozma, A. S., Stone, S., & Stones, M. J. (2000). Stability in components and predictors of subjective well-being (SWB). In E. Diener & D. R. Rahtz (Eds.), *Advances in quality of life theory and research*, Vol. 1, pp. 13–30. London, UK: Kluwer Academic.
- Kline, R. B. (1998). *Principles and practices of structural equation modeling*. New York: Guilford.
- Jacobs, J. E., Lanza, S., Osgood, D. W., Eccles, J. S., & Wigfield, A. (2002). Changes in children's self-competence and values: Gender and domain differences across grades one through twelve. *Child development*, 73(2), 509-527. doi: 10.1111/1467-8624.00421
- Yu, X., Zhang, J. (2007). Factor analysis and psychometric evaluation of the Connor-Davidson resilience scale (CD-RISC) with Chinese people. *Social Behaviour and Personality*, 35, 19-30. doi:10.2224/sbp.2007.35.1.19
- Lee, Y. T., & Seligman, M. E. (1997). Are Americans more optimistic than the Chinese?. *Personality and Social Psychology Bulletin*, 23, 32-40. doi: 10.1177/0146167297231004
- Little, R. J. A., & Rubin, D. B. (2002). *Statistical Analysis with Missing Data*, 2nd edition, New York: John Wiley.
- Lyubomirsky, S., King, L., & Diener, E. (2005). The benefits of frequent positive affect: Does happiness lead to success?. *Psychological bulletin*, 131(6), 803. doi:10.1037/0033-2909.131.6.803
- Maxwell, S. E., & Cole, D. A. (2007). Bias in cross-sectional analyses of longitudinal mediation. *Psychological Methods*, 12, 23-44. doi: 10.1037/1082-989X.12.1.23

- Mesquita, B., & Frijda, N. H. (1992). Cultural variations in emotions: A review. *Psychological Bulletin*, 112, 179–204. doi: 10.1037/0033-2909.112.2.179
- Muthén, L., & Muthén, B. (2006). *Mplus User's Guide*. Muthén & Muthén, Los Angeles, CA.
- Peterson, C., Seligman, M. E., & Vaillant, G. E. (1988). Pessimistic explanatory style is a risk factor for physical illness: A thirty-five-year longitudinal study. *Journal of Personality and Social Psychology*, 55(1), 23. doi: 10.1037/0022-3514.55.1.23
- Ruble, D. N., Eisenberg, R., & Higgins, E. T. (1994). Developmental changes in achievement evaluation: Motivational implications of self-other differences. *Child Development*, 65(4), 1095-1110. doi: 10.1111/j.1467-8624.1994.tb00805.x
- Scheier, M. F., & Carver, C. S. (1993). On the power of positive thinking: Benefits of being optimistic. *Current Directions in Psychological Science*, 2, 26–30. doi: 10.1111/1467-8721.ep10770572
- Scheier, M. F., Carver, C. S., & Bridges, M. W. (1994). Distinguishing optimism from neuroticism (and trait anxiety, self-mastery, and self-esteem): A reevaluation of the Life Orientation Test. *Journal of Personality and Social Psychology*, 67, 1063–1078. doi: 10.1037/0022-3514.67.6.1063
- Schuster, B., Ruble, D. N., & Weinert, F. E. (1998). Causal inferences and the positivity bias in children: The role of the covariation principle. *Child Development*, 69(6), 1577-1596. doi: 10.1111/j.1467-8624.1998.tb06178.x
- Seligman, M. E., & Csikszentmihalyi, M. (2000). Positive psychology: An introduction. *American psychologist*, 55(1), 5. doi: 10.1037/0003-066X.55.1.5
- Tanaka, J. S. (1993). Multifaceted conceptions of fit in structural equation models. In K. A. Bollen & J. S. Long (Eds.), *Testing structural equation models*, pp.10–39. Newbury Park, CA:Sage.
- Tusaie-Mumford, K. (2001). Psychosocial resilience in rural adolescents: Optimism. Perceived social support and gender differences. Unpublished doctoral dissertation, University of Pittsburgh. PA. Use disorders. *American Journal of Psychiatry*, 160, 496–503.

Vecchione, M., Alessandri, G., Barbaranelli, C., Gerbino, M. (2010). Stability and change of ego resiliency from late adolescence to young adulthood: A multiperspective study using the ER89-R scale. *Journal of Personality Assessment*, 92, 1-10.
doi:10.1080/00223891003670166

Werner, E., & R. Smith. (1992). *Overcoming the odds: High-risk children from birth to adulthood*. New York: Cornell University Press.

CHAPTER II Reciprocal relation between Ego-resiliency and Emotional Self-efficacy Beliefs across time

1. Introduction

In this study we examined the role of emotional self-efficacy beliefs as mechanisms that can promote the development of ego-resiliency in youths during the transition from late adolescence to emerging adulthood. Whereas the benefits of ego-resiliency have been highlighted by several empirical studies (Block & Block, 2006), considerably less attention has been paid to the identification of reliable predictors of ego-resiliency development. We sought to fill this gap in literature by using data from a large sample of late adolescents who repeatedly completed measures of ego-resiliency and emotional self-efficacy beliefs across eight years.

2. Emotional Self-efficacy Beliefs

Social cognitive theorists view personality as a cognitive affective system resulting from the concerted action of functionally distinct structures that gradually take form over the course of development (Bandura, 1986). Social cognitive approaches, in particular, have addressed the psychological mechanisms that enable people to interact effectively with the environment, to assign

personal meaning to their actions, and to plan and execute the course of actions in accordance with their personal goals and standards (Bandura, 1986). This emphasis has led to a focus on the unique properties of human agency such as self-reflection and self-regulation that enable people to capitalize upon their own and others' experience, to select and change the environments in which they live, and to contribute to charting the course of their life (Bandura, 2001).

Among psychological structures attesting to individuals' agentic power, none has proved to exert a more pervasive influence over thought, motivation, and action than self-efficacy beliefs, namely, judgments people hold about their capacity to cope effectively with specific challenges and to face demanding situations. The self-assurance with which people approach and manage difficult tasks determines whether they make good or poor use of their competencies. As evidenced in empirical studies, a strong sense of personal efficacy appears to overrule insidious self-doubt and sustain the development of various competencies and the regulation of action (Bandura, 2001; Murray, Holmes, Griffin, Bellavia & Rose, 2001; Schwarzer, 1996).

Although empirical findings have largely supported the substantial influence of self-efficacy beliefs on individual functioning in diverse domains (see Bandura, 1997, for a review), in the present study we focused on perceived emotional self-efficacy in the domain of affect regulation. Following the common distinction between positive and negative affect (Russell & Carroll, 1999; Watson & Tellegen, 1985), Caprara et al (2008) argued for the importance of emotional self-efficacy beliefs in both managing or modulating the expression of negative affect and impulsivity and appropriately experiencing and expressing positive affect especially in difficult situations (Bandura et al., 2003; Caprara, 2002). In fact, in the face of provocative circumstances and stressors, people who cannot sufficiently modulate their strong negative emotions may externalize negative feelings inappropriately (Eisenberg et al., 2001), including anger and irritation (Olson, Schilling, & Bates, 1999), or may be overwhelmed by fear, anxiety, or depression (Flett, Blankstein, & Obertinsky, 1996). In contrast, experiencing positive affect can enhance cognitive functioning, buffer the perturbing effects of aversive experiences, facilitate adaptive coping (Folkman &

Moskowitz, 2000) and lead to rewarding and enriching social exchanges and experiences (Fredrickson & Joiner, 2002).

Although the concept of emotional self-efficacy shares some similarities with that of emotion-related self-regulation (Derryberry & Rothbart, 1997; Rothbart et al., 2000), it is important to recognize the conceptual distinction between actually being able to self-regulate and feeling competent of doing so. Emotion-related self-regulation refers to a person's ability to understand and manage internal feelings and emotions by engaging in appropriate cognitive and behavioral strategies (Eisenberg & Spinrad, 2004). Instead, emotional self-efficacy reflects a person's perceived abilities to self-regulate, which may not always entirely reflect their true level of self-regulation. Some individuals may not fully recognize their own competencies whereas others may overestimate their own abilities.

Perceived emotional self-efficacy beliefs therefore entail a subjective self-appraisal of one's own emotional competence in the domain of emotion regulation. Consequently, measures of emotional self-efficacy beliefs are expected to relate only modestly to moderately to measures of positive and negative states (correlations are, in fact, in the range of .30, see Caprara, et al. 2008) as the perception of one's own abilities is substantively different from the assessment of one's own emotional state. Thus, from a more theoretical point of view, self-efficacy beliefs in managing negative emotion refer to beliefs regarding one's capability to improve negative emotional states once they are aroused in response to adversity or frustrating events and to avoid being overcome by emotions such as anger, irritation, despondency and discouragement. Self-efficacy beliefs in expressing positive emotions refer to beliefs in one's ability to experience or allow one to express positive emotions such as joy, enthusiasm and pride in response to success or pleasant events.

It is unlikely that people flexibly adapt to novel and unknown situations, avoid rigid responses under stress, and approach reality with curiosity and enthusiasm if they do not believe that they are able to master both emotions associated with the repeated experiences of multiple daily hassles and serious life difficulties. Consistent with the view that emotional self-efficacy beliefs

contribute to development, such beliefs predict changes in very stable and solid personality traits, such as emotional stability (Caprara, Vecchione, Barbaranelli, & Alessandri, 2012) and positive orientation (Caprara, Alessandri, & Barbaranelli, 2010).

Self-efficacy beliefs do not operate in isolation from one another and may be generalized, at least to some degree, across activities and situations, albeit in relation to a specific domain of individual functioning. Thus, one might expect modest relations between self-efficacy beliefs in the ability to manage negative emotions and self-efficacy beliefs in the ability to express positive emotions. In a previous longitudinal study, Alessandri, Caprara, Eisenberg & Steca (2009) investigated the relations between the two different kinds of emotional self-efficacy beliefs (i.e., managing negative emotions and expressing positive emotions). Self-efficacy beliefs in managing negative emotions were predicted by self-efficacy beliefs in expressing positive emotions only during late adolescence (from 18 to 22 years). This relation in the opposite direct (i.e., from self-efficacy beliefs in managing negative emotions to self-efficacy beliefs in expressing positive emotions) was not significant (both from 16 to 20 years and from 18 to 22 years).

Other research suggested age and gender differences in emotional self-efficacy. Caprara, Caprara, and Steca, (2003) found that men appeared to enter adulthood with a more robust sense of personal efficacy in dealing with negative affect compared to women, whereas women's sense of personal efficacy in dealing with negative affect improved from early adulthood to old age. Both men and women's sense of personal efficacy in expressing positive affect declined across age groups, but men had higher scores (Caprara et al., 2003).

3. Relations between Ego-Resiliency and Emotional Self-Efficacy Beliefs

From a theoretical point of view, ego-resiliency and self-efficacy beliefs are different constructs that draw upon different scientific traditions and address different aspects of personality. In principle, they can be mutually informative. The construct of ego-resiliency refers to an individual characteristic “reflecting general resourcefulness, sturdiness of character, and flexibility

of functioning in response to varying environmental circumstances” (Luthar, Cicchetti & Becker, 2000, p. 546) and is often viewed as closely associated with the ability of flexibly modulate the level of control and, hence, to emotional regulation (see Derryberry & Rothbart, 1997; Eisenberg, 2002). In contrast, self-efficacy beliefs point to self-regulatory processes and mechanisms that allow people to reflect upon themselves and to learn from their own and others’ experiences (Caprara et al, 2012). In addition, contrary to ego-resiliency, self-efficacy beliefs reflect highly contextualized knowledge structures that affect appraisal processes, which in turn guide actions (Bandura, 1997).

In spite of these differences, previous studies provided support for the association between emotional self-efficacy beliefs and ego-resiliency during the transition to adulthood. In particular, using a 10-year longitudinal design, Alessandri, Eisenberg, Vecchione, Milioni, and Caprara (2013) found that the mean-level trajectory of ego-resiliency from ages 15 to 19 was moderated by self-efficacy beliefs in managing negative emotions, and that the trajectory from ages 19 to 25 was moderated by the experience of familial support and self-efficacy beliefs in expressing positive emotions at age 15. This suggested that emotional self-efficacy beliefs might play a significant role in accounting for individual differences in the growth trajectory of ego-resiliency.

4. Aim of the Present Study

The present study was conceived to further investigate the relations between ego-resiliency and emotional self-efficacy beliefs using a longitudinal panel design in which the stability of constructs was taken into account to better assess potential causal relations. The expected direction of the effect is illustrated in Figure 1. As previously noted, we consider ego-resiliency and emotional self-efficacy beliefs to be constructs that occupy different layers in the architecture of personality. Ego-resiliency is a relatively unconditional and broad disposition referring to an individual basic potential, or, simply what a person “has” (see Asendorpf & Denissen, 2006; Asendorpf & van Aken, 2003). Emotional self-efficacy is a knowledge structure (i.e., a set of self-related beliefs) operating at an intermediate level between broad dispositions and specific behaviors,

and mostly represents an individual's characteristic adaptation (McAdams, 1999). This reasoning echoes previous distinctions made by both McAdams (1995) and Graziano, Jensen-Campbell and Finch (1997) with regard to levels of analysis in personality psychology. Furthermore, it embraces their view that individual differences in personality should be addressed at different levels, as well as the belief that a comprehensive view of personality should account for both traits and self-processes.

Conceiving ego-resiliency as a relatively unconditional, temperamental-like trait (Block & Block, 1980; Caspi & Silva, 1995), we reasoned that ego-resiliency might predict emotional self-efficacy beliefs. This is because experiencing oneself as an individual able to adapt resourcefully to changing and demanding circumstances and flexibly use problem-solving strategies (versus experiencing feelings of vulnerability to negative emotionality or environmental stressors) might provide the conditions for formulating, practicing, and further strengthening the abilities that are at the basis of emotional self-efficacy beliefs. In brief, we suggest that because ego-resiliency is a fundamental and early-appearing aspect of temperament and personality (Caspi & Shiner, 2006; Eisenberg et al., 2006; Rothbart & Bates, 2006; Taylor et al., 2013), it is reasonable that it would operate as a significant predictor of beliefs about the self.

Second, we reasoned that emotional self-efficacy beliefs may, in turn, predict individuals' overall ability to appropriately self-regulate and, thus be resilient (Block & Block, 1980) across different situations and across time. Indeed, distinct emotional self-efficacy beliefs play a crucial role in overruling or modulating the expression of negative affect and impulsivity versus the ability to appropriately experience and express positive affect (Bandura et al., 2003; Caprara, 2002). This hypothesis is partly confirmed by a previous longitudinal study on how emotional self-efficacy beliefs predicted ego-resiliency (Alessandri, et al. 2013).

Furthermore, it is likely that self-evaluations of one's own ego-resiliency contribute to an individual's experience as being effective in dealing with the appropriate expression of positive emotions and in managing the urgency of negative experiences. In addition, perceiving oneself as a

resilient individual may affect self-perceptions of how capable one is in dealing with positive and negative emotions. Because being optimally regulated helps in meeting the social standards of behaviors approved by significant others, it is likely that resilient individuals progressively gain confidence in their capability to regulate emotions. Thus, we hypothesized that ego-resiliency may act as a mediator in the development of perceived self-efficacy beliefs in managing negative emotions and in expressing positive emotions.

In summary, the above reasoning led us to examine the reciprocity of relations between ego-resiliency and emotional self-efficacy beliefs. Perceiving oneself as able to successfully manage negative emotions and appropriately express positive emotions may strengthen one's self-report of ego-resiliency. Self-perception theory (Bem, 1972) would suggest that at least a part of one's stable tendency to successfully deal with emotions might derive from seeing oneself as able to behave in that way. However, we expected the prediction of emotional self-efficacy beliefs from ego-resiliency to be stronger than vice versa because core traits are expected to be more stable than characteristic adaptations. This may therefore leave little variance to be predicted by emotional self-efficacy beliefs. Finally, because only one study has examined the reciprocal relations between the two kinds of emotional self-efficacy from 16 to 22 years (Alessandri et al., 2009), we investigated the longitudinal relations between different emotional self-efficacy beliefs in an exploratory manner.

5. Method

5.1 Participants

The participants were from families involved in the same ongoing longitudinal research presented in Studies 1.

The participants were 450 older adolescents, 239 females and 211 males, ranging from 16 to 18 years old at Time 1 (henceforth labelled T1; *mean* age = 17, *SD* = .80), from 18 to 20 years old at Time 2 (T2; *mean* age = 19, *SD* = .80), from 20 to 22 years old at Time 3 (T3; *mean* age = 21, *SD* = .82), and from 24 to 26 years old at Time 4 (T4; *mean* age = 25, *SD* = .80). Most participants were

attending high school at T1 and T2 (from 18 to 19 years). At T3 and T4, approximately half (54.7% at T3 and 49% at T4) were college students.

5.1.1. Attrition Analyses

At the final assessment after eight years, 55.3% of the sample contributed data to the study. In particular, all the participants (i.e., 100%) were assessed at T2, 17% (13% females and 22.3 % males) were not assessed at T3, and 44.7% (37.2% females and 53.1% males) were not assessed at T4. The attrition was mainly due to the inavailability of individuals to take part in this phase of the study or, in some cases, to the inability to contact the participant. Analyses of variance suggested that the attrited participants did not significantly differ from their counterparts in the means and the covariances of the examined variables as tested by a multivariate analysis of variance and *Box-M* test for homogeneity of covariance matrices.

5.2. Procedure

All the procedures used in the longitudinal study were the same as the previous study and are described better in the previous chapter (see Chapter I).

Figure 1. Conceptual Model of the Paths of Influence of Regulative Emotional Self-Efficacy Beliefs on Individual's Ego-Resiliency Assessed at T1, at T2, at T3 and T4. SE Positive Emotion = Positive Self-Efficacy Beliefs; SE Negative Emotion = Negative Self-Efficacy Beliefs

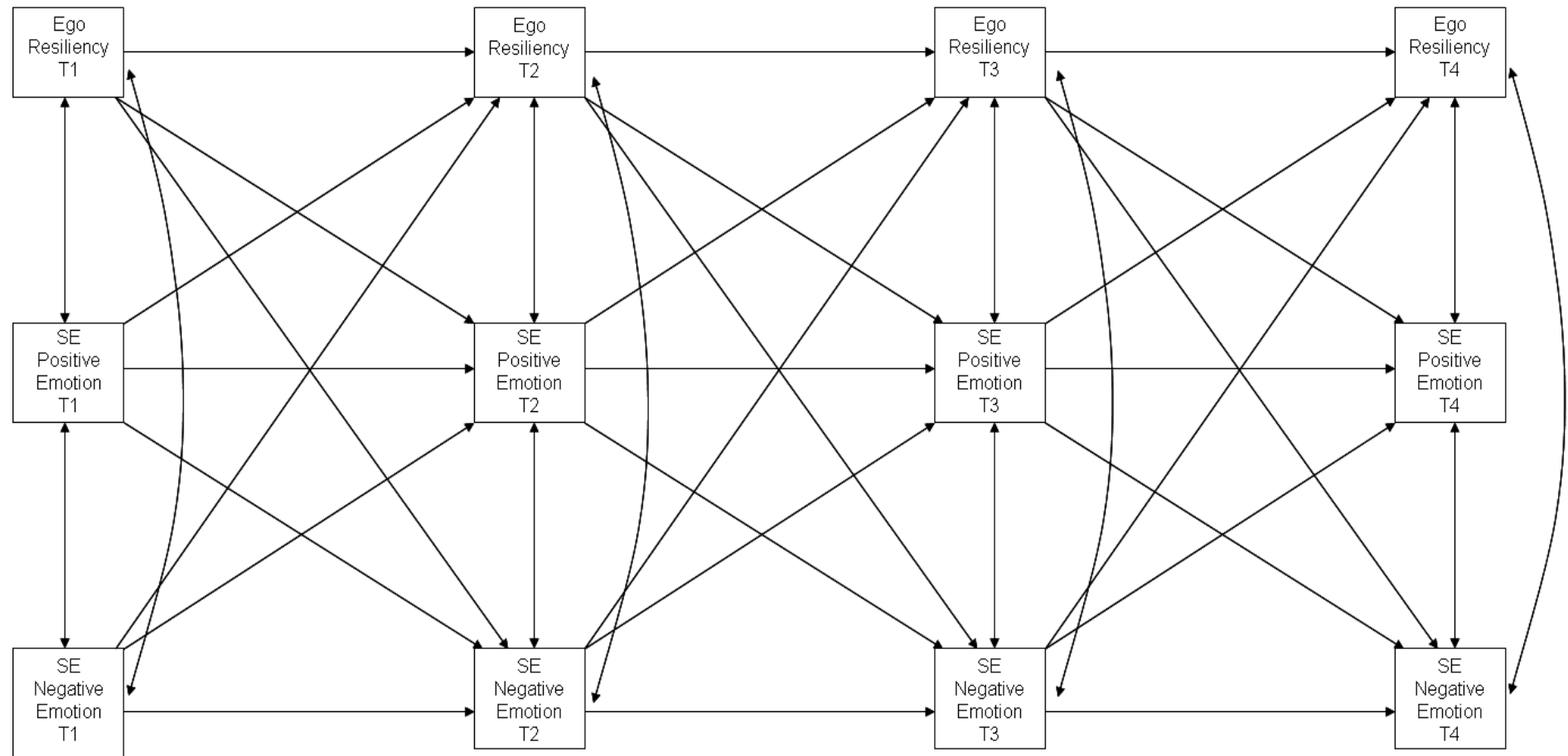

5.3. Measures

The measures were all self-report scales and included measures of self-efficacy beliefs in managing negative emotions, self-efficacy beliefs in expressing positive emotions, and ego-resiliency administered at each time point.

Emotional self-efficacy. Emotional self-efficacy beliefs were measured with two scales assessing the perceived capability to manage negative affect and to express positive affect (Caprara & Gerbino, 2001). Six items measured one's perceived capability to regulate negative affect in the face of anxiety-arousing threats, anger provocation, rejection, disrespect and the ability to control worrying or anxiety when things go wrong (e.g., "How well can you keep from getting discouraged by strong criticism?" and "How well can you get over irritation quickly for wrongs you have experienced?"; alphas = .76, .77, .83 and .65 at T1, T2, T3 and T4, respectively). Three items assessed the participants' perceived capability to express positive affect such as liking and affection toward others, enthusiasm and enjoyment and satisfaction after personal accomplishments (e.g., "How well can you express joy when good things happen to you?"; alphas at T1, T2, T3 and T4 = .69, .80, .81 and .80, respectively). For each set of items assessing emotional self-efficacy, participants rated the strength of their self-efficacy beliefs on a scale ranging from 1 (not well at all) to 5 (very well).

Ego-resiliency. The ER89-R (Alessandri et al., 2008; Vecchione, et al. 2010) is a brief inventory composed of 10 items. Participants were asked to indicate the degree to which they agreed with each statement on a scale ranging from 1 (does not apply at all) to 4 (applies very strongly). High correlations with the original measure devised by Block and Kremen (1996) have confirmed the construct validity of the scale (Alessandri et al., 2008; Vecchione, et al. 2010). The psychometric properties of the instrument have been documented in a large sample of Italian respondents (Alessandri et al., 2008) and confirmed in both cross-cultural and longitudinal research (Alessandri, Vecchione, Letziring, & Caprara, 2012; Vecchione et al., 2010). Sample items include

“I quickly get over and recover from being startled,” and “I get over my anger at someone reasonably quickly” (alphas = .82, .84, .87, and .83, from T1 to T4, respectively).

5.4. Preliminary Analyses

To investigate the dimensionality of the measures, as well as their discriminant validity, principal factor analysis with Promax rotation was performed at each assessment point. The screeplot and the pattern of loadings indicated that a structure with three factors corresponding to the hypothesized constructs (i.e., two factors corresponding to the two domains of self-efficacy and one factor corresponding to ego-resiliency) could be obtained at each time point. The loadings on the intended factors ranged from .36 to .84 ($M = .60$; $SD = .34$) across the four assessment points. The secondary loadings varied from $-.28$ to $.30$ ($M = .25$; $SD = .18$). Factor correlations ranged from $.33$ to $.42$ across the four assessments. These results supported the factorial validity of the measures and the empirical distinctiveness of the three constructs.

6. Results

Using one-way analyses of variance (ANOVA), we first examined sex differences in the measures within each of the four time points. Next, we examined the zero-order correlations among the variables, both within time and across time. Third, we used structural equation modeling to test the aforementioned hypotheses.

6.1. Descriptive Statistics

Table 1 presents the means and standard deviations for emotional self-efficacy beliefs and ego-resiliency at T1, T2, T3 and T4. One-way analyses of variance indicated that there were significant gender differences for all the assessed variables except for ego-resiliency at T3 and T4 (see Table 1). Males reported a stronger sense of efficacy in managing negative emotion than females, whereas females felt more efficacious in expressing positive emotion. With respect to ego-

resiliency, females were more resilient than males at T1 and T2 (i.e., from 16 to 21 years), but there were no gender differences at T3 and T4 (i.e., from 20 to 26 years).

Table 2 contains the zero-order correlations between emotional self-efficacy beliefs and ego-resiliency. High correlations across time indicated high stability for both self-efficacy beliefs and ego-resiliency. As expected, at each assessment self-efficacy beliefs in managing negative emotions, self-efficacy beliefs in expressing positive emotions and ego-resiliency were positively and highly related to each other for both sexes.

Table 1. Mean, Standard Deviation and Sex Differences for Regulative Emotional Self-Efficacy beliefs and Ego-Resiliency at each of the four Assessments for Males and Females

Variable	Males		Females		Sex	
	M	SD	M	SD	F (1, 450)	Sign.
Positive self-efficacy T1	4.17	.71	4.37	.62	9.69*	.002
Negative self-efficacy T1	3.49	.66	3.21	.70	18.12*	.000
Ego-resiliency T1	4.87	.74	5.03	.72	5.06*	.025
Positive self-efficacy T2	3.99	.78	4.41	.60	41.13*	.000
Negative self-efficacy T2	3.25	.61	3.08	.65	8.66*	.003
Ego-resiliency T2	4.84	.71	5.04	.78	8.28*	.004
Positive self-efficacy T3	4.06	.73	4.38	.68	19.12*	.000
Negative self-efficacy T3	3.41	.68	3.08	.81	17.71*	.000
Ego-resiliency T3	5.04	.86	5.07	.81	.11	.742
Positive self-efficacy T4	4.09	.66	4.27	.70	4.01*	.046
Negative self-efficacy T4	3.58	.76	3.28	.83	7.96*	.005
Ego-resiliency T4	5.14	.69	5.11	.73	.09	.759

Note. * $p < .05$. T1 = variable assessed at Time 1; T2 = variable assessed at Time 2; T3 = variable assessed at Time 3; T4 = variable assessed at Time 4. F = F ratio resulted from one-way analyses of variance; the degrees of freedom and the number of participants are within the parentheses.

Table 2. Zero-order Correlations among Measures of Regulative Emotional Self-Efficacy and Ego-Resiliency for Males and Females.

	1	2	3	4	5	6	7	8	9	10	11	12
1. Pos-sef T1	1	0.26**	0.48**	0.37**	0.23**	0.44**	0.29**	0.15*	0.28**	0.15	0.03	0.22**
2. Neg-sef T1	0.36**	1	0.34**	0.13*	0.50**	0.33**	0.13	0.37**	0.29**	0.12	0.34**	0.28**
3. Ego-res T1	0.43**	0.41**	1	0.34**	0.30**	0.55**	0.13	0.12	0.39**	0.12	0.23**	0.37**
4. Pos-sef T2	0.45**	0.24**	0.30**	1	0.26**	0.40**	0.27**	0.07	0.24**	0.24**	0.15	0.20*
5. Neg-sef T2	0.09	0.35**	0.23**	0.27**	1	0.45**	0.08	0.42**	0.29**	0.07	0.41**	0.33**
6. Ego-res T2	0.32**	0.35**	0.55**	0.45**	0.32**	1	0.20**	0.22**	0.54**	0.16*	0.28**	0.51**
7. Pos-sef T3	0.33**	0.18*	0.37**	0.45**	0.10	0.44**	1	0.48**	0.40**	0.54**	0.24**	0.44**
8. Neg-sef T3	0.20**	0.37**	0.32**	0.39**	0.40**	0.43**	0.46**	1	0.30**	0.28**	0.52**	0.42**
9. Ego-res T3	0.15*	0.29**	0.36**	0.30**	0.24**	0.43**	0.41**	0.39**	1	0.32**	0.26**	0.67**
10. Pos-sef T4	0.14	0.13	0.20*	0.32**	0.13	0.27**	0.57**	0.31**	0.17	1	0.28**	0.35**
11. Neg-sef T4	0.26**	0.38**	0.33**	0.22*	0.42**	0.31**	0.21*	0.51**	0.10	0.23**	1	0.46**
12. Ego-res T4	0.24*	0.35**	0.48**	0.26**	0.07	0.47**	0.37**	0.35**	0.24*	0.46**	0.28**	1

Note. The correlation coefficients below the diagonal are for males; the correlation coefficients above the diagonal are for females; T1 = variable assessed at Time 1; T2 = variable assessed at Time 2; T3 = variable assessed at Time 3; T4 = variable assessed at Time 4. Pos-sef = Positive Self-Efficacy Beliefs; Neg-sef = Negative Self-Efficacy Beliefs; Ego-res = Ego-Resilience. ** $p < .01$; * $p < .05$.

6.2. Modeling Strategies

We tested our theoretical model using a four-wave mediational design, following the suggestions of Cole and Maxwell (2003; Maxwell and Cole, 2007). In particular, we estimated a model that included (a) all the autoregressive paths (i.e., the paths predicting a variable from its prior level), as well as the across-time paths from (b) ego-resiliency at a given time point to both types of self-efficacy beliefs at the subsequent time point; (c) self-efficacy belief in expressing positive emotion at a given time point to ego-resiliency at the subsequent time point; (d) self-efficacy belief in managing negative emotion at a given time point to ego-resiliency at the subsequent time point; (e) self-efficacy belief in expressing positive emotion at a given time point to self-efficacy belief in managing negative emotion at the subsequent time point; (f) self-efficacy belief in managing negative emotion at a given time point to self-efficacy belief in expressing positive emotion at the subsequent time point. In addition, all the variables were allowed to covary within time.

6.3. Structural Equation Analysis

To estimate the hypothesized model, we used *Mplus* 5.01 (Muthén & Muthén, 2006). Missing data were handled by using Full Information Maximum Likelihood Estimation (*FIML*). This estimator maximizes the number of participants whose data contribute to the covariance matrix to be analyzed. Compared to other methods for handling missing data, *FIML* produces more reliable estimates for parameters and goodness of fit indices (Enders & Bandalos, 2001). According to a multifaceted approach to the assessment of model fit (Tanaka, 1993), the following criteria were employed to evaluate the goodness of tested models: χ^2 likelihood ratio statistic, Tucker and Lewis Index (*TLI*), Comparative Fit Index (*CFI*), and the Root Mean Square Error of Approximation (*RMSEA*) with associated confidence intervals. The significance value of chi-square is sensitive to large sample sizes and easily produces a statistically significant result (Kline, 1998). We accepted

TLI and *CFI* values greater than .95 (Hu & Bentler, 1999) and *RMSEA* values lower than .06 (Browne & Cudeck, 1993).

To test the possible moderating effects of sex, we used multiple-group structural equation modeling (Muthén & Muthén, 2006). In our approach, the equivalence between male and female groups was evaluated by imposing identical unstandardized estimates for autoregressive and cross-lagged paths (we refer to this model as the *sex-constrained model*). The plausibility of these equality constraints was examined with the modification indices and the χ^2 difference test between nested models (i.e., the sex constrained model vs. the unconstrained model; see Bollen, 1989). We used the same procedure to constrain the autoregressive and cross-lagged paths to be equal across time. In this model (i.e., the *sex-time constrained model*), equality constraints were simultaneously applied across sex and across time.

Mediated effects were calculated using the procedures outlined by MacKinnon, Lockwood, Hoffman, West, and Sheets (2002). We followed the asymmetric confidence interval method recommended by MacKinnon et al. (2002) to formally test mediation (MacKinnon et al., 2004). The critical values for the upper and lower confidence limits for indirect effects were calculated based on the product of two random variables by using the program *PRODCLIN2* (Fritz & MacKinnon, 2007; MacKinnon, Fritz, Williams, & Lockwood, 2007).

6.4. Longitudinal Modeling

The *sex constrained model* showed a good fit to the data: $\chi^2(77) = 99.831$, $p = .041$, *CFI* = .982, *TLI* = .971, *RMSEA* = .042 (.009 - .063). Following standard procedures, we examined the gain in fit achieved by freely estimating all paths across sexes. The change in fit between the *sex constrained* versus the *unconstrained model* was not significant: $\Delta\chi^2(27) = 21.974$, $p = .74$, supporting the tenability of the constraints imposed across male and female groups. We then estimated the *sex-time constrained model* by further imposing equality constraints across time. This model fitted the data well $\chi^2(95) = 139.001$, $p < .01$, *CFI* = .965, *TLI* = .954, *RMSEA* = .052 (.032 -

.070). Furthermore, the change in fit between the *sex-time constrained* model versus the *unconstrained model* was not significant: $\Delta\chi^2(45) = 61.144, p = .06$. This best-fitting model is illustrated in Figure 2.

As can be observed, all the autoregressive paths were significant. All examined variables at T1 significantly predicted the same variables at T2, and so on for the subsequent time points, demonstrating an high degree of stability over time. In addition, both self-efficacy beliefs in managing negative emotions and in expressing positive emotions significantly predicted ego-resiliency from T1 to T2, from T2 to T3, and from T3 to T4. At the same time, ego-resiliency predicted both emotional self-efficacy beliefs from T1 to T2, from T2 to T3, and from T3 to T4. All of these longitudinal predictions held above and beyond the stability of the variables. This result suggests that ego-resiliency and emotional self-efficacy beliefs reciprocally affect the development of each other during a long period of time, which ranges from adolescence to emerging adulthood. In contrast, reciprocal relations between self-efficacy beliefs in managing negative emotions and in expressing positive emotions were not observed.

Next, we tested whether the effects of each variable assessed at one time point (i.e., ego-resiliency at T1) on later scores of the same variable (i.e., ego-resiliency at T3) were longitudinally mediated by the other variables (i.e., by emotional self-efficacy beliefs at T2). We found that the unstandardized indirect effect of self-efficacy beliefs in managing negative emotions at T1 on self-efficacy beliefs in managing negative emotions at T3 through ego-resiliency at T2 was significant ($b = .013; z = 2.60$) and that the associated confidence interval (CI) did not include zero (.004, .025), thus supporting mediation. The unstandardized indirect effect of self-efficacy beliefs in managing negative emotions at T2 on self-efficacy beliefs in managing negative emotions at T4 through ego-resiliency at T3 was also significant (parameter estimate, statistical test, and CI were identical to those of the mediated effect described above as the paths were all constrained to be equal across time). Similarly, the indirect effect of self-efficacy beliefs in expressing positive emotions at T1 on self-efficacy beliefs in expressing positive emotions at T3 through ego-resiliency at T2 was

significant, as well as the indirect effect of self-efficacy beliefs in expressing positive emotions at T2 on self-efficacy beliefs in expressing positive emotions at T4 through ego-resiliency at T3 ($b = .013$; $z = 2.20$, $CI = .002, .027$).

The same pattern was found for the mediating role of self-efficacy on across-time indices of ego-resiliency. The unstandardized indirect effect of ego-resiliency at T1 on ego-resiliency at T3 through self-efficacy beliefs in managing negative emotions at T2, and that from T2 to T4 through self-efficacy beliefs in managing negative emotions at T3, were both significant ($b = .013$; $z = 2.60$, $CI = .004, .025$). The indirect effect of ego-resiliency at T1 on ego-resiliency at T3 through self-efficacy beliefs in expressing positive emotions at T2 and the analogous relation from T2 to T4 were also significant ($b = .013$; $z = 2.20$, $CI = .002, .027$, for both relations). All the mediated paths were found to be equal for males and females.

The model accounted for a large proportion of variability for all the variables, with little or no apparent difference between males and females. Specifically, (averaging for males and females), R-squared at T2 were 28% for self-efficacy beliefs in managing negative emotions, 27% for self-efficacy beliefs in expressing positive emotions and 37% for ego-resiliency; at T3, they were 29% for self-efficacy beliefs in managing negative emotions, 28% for self-efficacy beliefs in expressing positive emotions and 28% for ego-resiliency; at T4, they were 27% for self-efficacy beliefs in managing negative emotions, 26% for self-efficacy beliefs in expressing positive emotions and 44% for ego-resiliency.

Figure 2. Longitudinal relations between Emotional Self-Efficacy beliefs and individuals' Ego-Resiliency assessed at T1, at T2, at T3 and T4 in the *sex-time constrained model*.

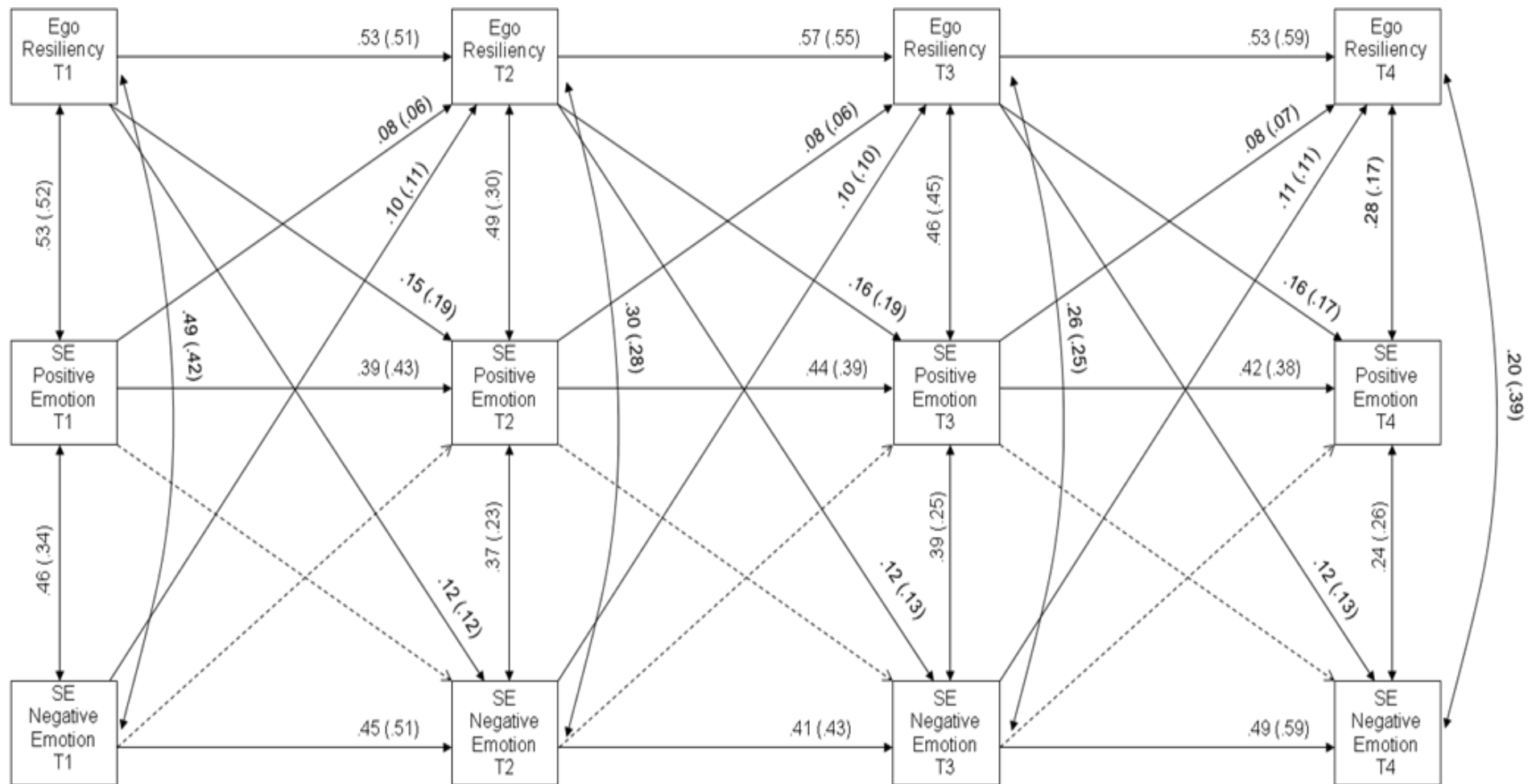

Note. Solid lines represent significant paths, dashed lines represent not significant path. Reported coefficients refer to standardized estimates for males and for females (in parentheses), respectively. All parameters are significant beyond $p < .05$

7. Discussion

Researchers have acknowledged the importance of ego-resiliency for individuals' positive social functioning and youths' later outcomes. However, relatively little research has focused on the relations of ego-resiliency with other personality variables over the course of development. This study examined the reciprocal relations of ego-resiliency with perceived self-efficacy in managing negative emotions and in expressing positive emotions in the transition from late adolescence to emerging adulthood. As hypothesized, findings from this longitudinal investigation indicated that self-efficacy beliefs in managing negative emotions and in expressing positive emotions were significantly associated with the development of ego-resiliency over time. In their own right, these results represent an important contribution to the design of applied interventions aimed at fostering the development of resilience in youths. Furthermore, our findings extend results from Alessandri et al. (2013) by clarifying the likely direction of the influence between ego-resiliency and emotional self-efficacy beliefs.

In accordance with our first hypothesis, ego-resiliency significantly predicted the development of emotional self-efficacy beliefs. It is likely that experiencing oneself as an individual able to resourcefully adapt to changing circumstances and to environmental stressors provides the conditions for practicing and further strengthening the abilities that are form the basis of feeling efficacious. Self-perception theory (Bem, 1972) would suggest that feelings of emotional self-efficacy derive, at least in part, from seeing oneself as able to regulate emotionality under a large variety of environmental circumstances (i.e., from the more adverse to the more favorable).

In accordance with our second hypothesis, emotional self-efficacy beliefs predicted ego-resiliency. Self-efficacy beliefs regulate human functioning and emotional well-being through cognitive, motivational, affective and selective processes. As such, emotional self-efficacy is likely to affect individuals' ability to adapt and to deal with difficult situations flexibly, and enhance perseverance in the face of failure (Bandura et al., 2001). These qualities are relevant for the development of youths' ego-resiliency. To successfully address the multitude of challenges and

tasks associated with this transitional period (moving from college to University, getting married, starting work, etc.), youths should possess robust self-efficacy beliefs (Bandura et al., 1999). Especially when faced with challenging situations, it is likely that self-efficacy beliefs are important in developing a sense of self-competence that, in turn, influences a person's ability to overcome the pernicious effects of adversities. Probably these beliefs can be important components of emotional competence in resilient adolescents (Aspinwall & Richter, 1999).

The reciprocity observed between emotional self-efficacy beliefs and ego-resiliency suggests that the two constructs reinforce each other over time. Both positive and negative emotional self-efficacy beliefs predicted the development of ego-resiliency over time, and ego-resiliency in turn predicted the development of emotional self-efficacy beliefs in both domains (emotional self-efficacy beliefs in expressing positive emotions and in managing negative emotions). These relations held even when controlling for the stability of all the constructs, providing some support (although not full support, of course) for causal interpretations.

Also of note, both types of emotional self-efficacy beliefs mediated part of the change observed in ego-resiliency over time. Likewise, ego-resiliency mediated part of the change in both emotional self-efficacy beliefs. These findings suggest that self-efficacy in modulating both positive and negative emotions may have unique effects on ego-resiliency and that ego-resiliency may have its own effect on both types of emotional self-efficacy. Although not tested, it is likely that emotional self-efficacy and ego-resiliency can each offer a specific contribution to optimal self-regulation by increasing the general capacity to tolerate and respond effectively to difficult situations and adverse emotions (Saarni, 1999).

Finally, the gender differences we found in the present study replicated those in previous research (Caprara, Caprara, & Steca, 2003; Caprara & Steca, 2005; 2007). At all ages, female adolescents and young adults reported higher self-efficacy beliefs in expressing positive emotions compared to their male counterparts. In contrast, male scored higher than females on self-efficacy beliefs in managing negative emotions. At T1 and T2 (but not T3 or T4), females rated themselves

as more resilient than males. Perhaps males and females are motivated differently to rate themselves in accordance with the perceived stereotypic gender roles. In fact, western societies tend to view the appropriate expression of positive emotion - the expression of internalizing negative emotions such as anxiety, sadness, and depression - and generally being more flexible and adaptable as feminine traits. On the other hand, the masculine role is often associated with impulsivity and higher levels of externalizing emotions such as anger and high intensity positive emotion (see Eisenberg, Martin, & Fabes, 1996; Else-Quest et al., 2006). However, we did not find any differences in model parameters and longitudinal relations observed among these constructs. Although the mean levels of the key variables of emotions varied across sex, the relations between perceived self-efficacy competencies and ego-resiliency appeared to unfold similarly over time. In contrast to the study of Alessandri et al (2009), our data did not support a reciprocal relation between self-efficacy beliefs in managing negative emotions and self-efficacy beliefs in expressing positive emotions. The development of self-efficacy in managing negative emotions and in expressing positive emotions therefore seem to be relatively independent.

By examining the pattern of findings from late adolescence into emerging adulthood, we hope to contribute to the understanding of the joint development of ego-resiliency and emotional self-efficacy beliefs and their correlations. The obtained findings can be useful in designing interventions aimed at strengthening ego-resiliency as they suggest that even such a stable disposition may be amenable to change through appropriate experiences. In this regard, sociocognitive theory provides useful and well-detailed guidelines (Bandura, 1997).

With regard to potential limitations of this study and future directions, it would be desirable to test the generalizability of our findings across different populations and cultural contexts. The beliefs in the regulation and expression of emotions and the concept of ego-resiliency may show important variations across social contexts and cultures (Mesquita & Frijda, 1992). The use of self-report data may be viewed as a major limitation that inevitably biases results. For example, the within-time correlations between measured variables might be inflated by the presence of common

method variance. However, this study embraces a long temporal span (8 years) and is focused on prospective relations that are less likely than contemporaneous data to be biased by method effects. Moreover, although the assessment of both ego-resiliency and perceived emotional self-efficacy would have benefited from the use of more than a single informant, one might argue that no one can report on an individual's own self-efficacy better than the participant himself. Specifically, no person is in a better position than an agent to know and report about his or her self-perceived beliefs to manage negative affect and express positive affect across contexts and situations. In future, it would be desirable to obtain measures of ego-resiliency from multiple informants (e.g., peer or family reports, behavioral measures). Although multiple measures of emotional self-efficacy might also be desirable, as already noted, it is difficult for a person to report on someone else's feelings of efficacy. Despite these limitations, we believe that the present results provide a methodologically rigorous description of the reciprocal relationship between emotional self-efficacy beliefs and ego-resiliency from late adolescence to emerging adulthood.

References

- Alessandri, G., Vecchio, G., Steca, P., Caprara, M. G., & Caprara, G.V. (2008). A revised version of Kremen and Block's ego-resiliency scale in an Italian Sample. *Testing, Psychometrics, Methodology in Applied Psychology*, 14, 1-19. doi: 10.1027/1015-5759/a000102
- Alessandri, G., Caprara, G.V., Eisenberg, N., Steca, P. (2009). Reciprocal relations among self-efficacy beliefs and prosociality across time. *Journal of Personality*, 77, 1229- 1259. doi: 10.1111/j.1467-6494.2009.00580.x
- Alessandri, G., Vecchione, M., Letziring, T., Caprara, G.V. (2012). The ego-resiliency scale revised: A cross-cultural study in Italy, Spain, and the United States. *European Journal of Psychological Assessment*, 28, 139-146. doi: 10.1027/1015-5759/a000102
- Alessandri, G., Eisenberg, N., Vecchione, M., Milioni, M., & Caprara, M. G. (2013). Ego-resiliency development from late adolescence to emerging adulthood: A ten-year longitudinal study. *Submitted Manuscript*.
- Asendorpf, J.B. & van Aken, M.A.G. (2003). Personality-relationship transaction in adolescence: Core versus surface personality characteristics. *Journal of personality*, 71, 629-666. doi: 10.1111/1467-6494.7104005
- Asendorpf, J.B. & Denissen, J.J.A. (2006). Predictive validity of personality types versus personality dimensions from early childhood to adulthood: Implications for the distinction between core and surface traits. *Merrill-Palmer Quarterly*, 52, 486-513. doi: 10.1353/mpq.2006.0022
- Aspinwall, L.G., & Richter, L. (1999). Optimism and self-mastery predict more rapid disengagement from unsolvable tasks in the presence of alternatives. *Motivation and Emotion*, 23, 221-245. doi: 10.1023/A: 1021367331817
- Bandura, A. (1986). *Social foundations of thought and action: A social cognitive theory*. Englewood Cliffs, NJ: Prentice- Hall, Inc.
- Bandura, A. (1997). *Self-efficacy: The exercise of control*. New York: Freeman.

- Bandura, A. (2001). Social cognitive theory: An agentic perspective. *Annual Review of Psychology*, 52, 1-26. doi: 10.1146/annurev.psych.52.1.1
- Bandura, A., Pastorelli, C., Barbaranelli, C. & Caprara, G.V. (1999). Self-efficacy pathways to childhood depression. *Journal of Personality and Social Psychology*, 76, 258-269. doi: 10.1037/0022-3514.76.2.258
- Bandura, A., Barbaranelli, C., Caprara, G.V., & Pastorelli, C. (2001). Self-efficacy beliefs as shapers of children's aspirations and career trajectories. *Child Development*, 72, 187-206. doi: 10.1111/1467-8624.00273
- Bandura, A., Caprara, G.V., Barbaranelli, C., Gerbino, M., Pastorelli, C. (2003). Role of affective self-regulatory efficacy in diverse spheres of psychosocial functioning. *Child Development*, 74, 769-782. doi: 10.1111/1467-8624.00567
- Bem, D. J. (1972). Self-perception theory. In L. Berkowitz (Ed.), *Advances in Experimental Social Psychology*, Vol 6, pp. 1-62. New York: Academic Press.
- Block, J.H., & Block, J. (1980). The role of ego-control and ego-resiliency in the organization of behavior. In W.A. Collins (Ed.), *Minnesota symposia on child psychology*, Vol 13, pp. 39-101. Hillsdale, NJ: Erlbaum.
- Block, J.H., & Kremen, A.M. (1996). IQ and Ego-resiliency: conceptual and empirical connections and separateness. *Journal of Personality and Social Psychology*, 70, 349-361. doi: 10.1006/jrpe.2001.2344
- Block, J.H., & Block, J. (2006). Venturing a 30-year longitudinal study. *American Psychologist*, 61, 315-327. doi: 10.1037/0003-066X.61.4.315
- Bollen, K.A. (1989). *Structural-equations with latent variables*. New York: Wiley.
- Browne, M.W. & Cudeck, R. (1993). Alternative ways of assessing model fit. In K.A. Bollen, & S.J. Long (eds). *Testing structural equation models*, pp. 137-162. Newbery Park: Sage.
- Caprara, G.V. (2002). Personality psychology: Filling the gap between basic processes and molar functioning. In C. von Hofsten & L. Bakman (Eds.), *Psychology at the turn of the*

Millennium: Social, developmental and clinical perspectives, Vol. 2, pp. 201-224. Hove, East Sussex, UK: Psychology Press.

- Caprara, G.V. & Gerbino, M. (2001). Autoefficacia emotiva percepita: La capacità di regolare l'affettività negativa e di esprimere quella positiva (Affective perceived self-efficacy: The capacity to regulate negative affect and to express positive affect). In G.V. Caprara (ed.). *La valutazione dell'autoefficacia (Self-efficacy assessment)*, pp. 35-50. Erickson: Trento.
- Caprara, G.V., Caprara, G., & Steca, P. (2003). Personality's correlates of adult development and aging. *European Psychologist*, 8, 131–147. doi: 10.1027//1016-9040.8.3.131
- Caprara, G. V., & Steca, P. (2005). Affective and social self-regulatory efficacy beliefs as determinants of positive thinking and happiness. *European Psychologist*, 10(4), 275-286. doi: 10.1027/1016-9040.10.4.275
- Caprara, G.V. & Steca, P. (2007). Prosocial agency: The contribution of values and self-efficacy beliefs to prosocial behavior across ages. *Journal of Social and Clinical Psychology*, 26, 220-241. doi: 10.1521/jscp.2007.26.2.218
- Caprara, G. V., Di Giunta, L., Eisenberg, N., Gerbino, M., Pastorelli, C., & Tramontano, C. (2008). Assessing regulatory emotional self-efficacy in three countries. *Psychological Assessment*, 20(3), 227-237. doi: 10.1037/1040-3590.20.3.227
- Caprara, G.V. , Alessandri, G., Barbaranelli, C. (2010). Optimal functioning: Contribution of self efficacy beliefs to positive orientation. *Psychotherapy and Psychosomatics*, 79, 328-330. doi: 10.1159/000319532
- Caprara, G.V., Vecchione, M., Barbaranelli, C., & Alessandri, G. (2012). Emotional stability and affective self- regulatory efficacy beliefs: Proofs of integration between trait theory and social cognitive theory. *European Journal of Personality*, 26. doi: 10.1002/per.1847
- Caspi, A., & Silva, P.A. (1995). Temperamental qualities at age three predict personality traits in young adulthood: Longitudinal evidence from a birth cohort. *Child Development*, 66 (2), 486-498. doi: 10.1111/j.1467-8624.1995.tb00885.x

- Caspi, A., & Shiner, R. L. (2006). Personality development. In W. Damon & R. Lerner (Series Eds.) & N. Eisenberg (Vol. Ed.), *Handbook of Child Psychology: Social, emotional, and personality development*, Vol. 3, pp. 300-365. New York: Wiley.
- Cole, D. A., & Maxwell, S. E. (2003). Testing mediational models with longitudinal data: Questions and tips in the use of structural equation modeling. *Journal of Abnormal Psychology*, 112, 558–577. doi: 10.1037/0021-843X.112.4.558
- Derryberry, D., & Rothbart, M.K. (1997). Reactive and effortful processes in the organization of temperament. *Development and Psychopathology*, 9, 633-652. doi: 10.1017/S0954579497001375
- Eisenberg, N., (2002). Emotion-related regulation and its relation to quality of social functioning. In W. Hartup, & R.A. Weinberg, (Eds), *Child psychology in retrospect and prospect: In celebration of the 75th anniversary of the Institute of Child Development. The Minnesota symposia on child psychology*, Vol 32., pp. 133-171. Mahwah, NJ, US: Lawrence Erlbaum Associates Publishers
- Eisenberg, N., Martin, C.L., & Fabes, R.A. (1996). Gender development and gender effects. In D. C. Berliner & R. C. Calfee (Eds.), *Handbook of Educational Psychology*, pp. 358-396. New York: MacMillan.
- Eisenberg, N., Cumberland, A., Spinrad, T.L., Fabes, R.A., Shepard, S.A., Reiser, M. (2001). The relations of regulation and emotionality to children's externalizing and internalizing problem behavior. *Child Development*, 72, 1112–1134. doi: 10.1111/1467-8624.00337
- Eisenberg, N., Spinrad, T.L. (2004a). Emotion-related regulation: Sharpening the definition. *Child Development*. 75, 334–339. doi: 10.1111/j.1467-8624.2004.00674.x
- Eisenberg, N., Fabes, R. A., & Spinrad, T. L. (2006). Prosocial development. In N. Eisenberg (Vol. Ed.), W. Damon & R. M. Lerner (Series Eds.), *Handbook of child psychology: Social, emotional, and personality development*, Vol. 3, pp. 646–718. New York: Wiley.

- Else-Quest, N.M., Hyde, J.S., Goldsmith, H.H., Van Hulle, C.A. (2006). Gender differences in temperament: a meta-analysis. *Psychological Bulletin*, 132, 33–72. doi: 10.1037/00332909.132.1.33
- Enders, C.K., & Bandalos, D.L. (2001). The relative performance of full information maximum likelihood estimation for missing data in structural equation modeling. *Structural Equation Modelling*, 8, 430-457. doi: 10.1207/S15328007SEM0803
- Flett, G.L., Blankstein, K.R., & Obertinsky, M. (1996). Affect intensity, coping style, mood regulation expectancies, and depressive symptoms. *Personality and Individual Differences*, 20, 221-228. doi: 10.1016/0191-8869(95)00163-8
- Folkman, S.K., & Moskowitz, J.T. (2000). Positive affect and the other side of coping. *American Psychologist*, 55, 647-654. doi: 10.1037//0003-066X.55.6.647
- Fredrickson, B.L., Joiner, T. (2002). Positive emotions trigger upward spirals toward emotional well-being. *Psychological Science*, 13, 172–175. doi: 10.1111/1467-9280.00431
- Fritz, M.S, MacKinnon, D.P. (2007). Required sample size to detect the mediated effect. *Psychological Science*, 18, 233–239. doi: 10.1111/j.1467-9280.2007.01882.x
- Graziano, W.G., Jensen-Campbell, L.A., & Finch, J.F. (1997). The self as a mediator between personality and adjustment. *Journal of Personality and Social Psychology*, 73, 392-404. doi: 10.1037/0022-3514.73.2.392
- Hu, L., & Bentler, P.M. (1999). Cutoff criteria for fit indexes in covariance structure analysis: Conventional criteria versus new alternatives. *Structural Equation Modeling*, 6, 1-55. doi: 10.1080/10705519909540118
- Istituto Italiano di Statistica (2002). *Annuario statistico italiano 2002 [Italian yearbook of statistics 2002]*. Rome: ISTAT.
- Luthar, S.S., Cicchetti, D., & Becker, B. (2000). The construct of resilience: A critical evaluation and guidelines for future work. *Child Development*, 71, 543–562. doi: 10.1111/14678624.00164

- Kline, R.B. (1998). *Principles and practices of structural equation modeling*. New York: Guilford.
- MacKinnon, D.P., Lockwood, C.M., Hoffman, J.M., West, S.G., Sheets, V.A. (2002). Comparisons of methods to test mediation and other intervening variable effects. *Psychological Methods*, 7, 83–104. doi: 10.1037//1082-989X.7.1.83
- MacKinnon, D.P, Lockwood, C.M, Williams, J. (2004). Confidence limits for the indirect effect: Distribution of products and resampling methods. *Multivariate Behavioral Research*, 39, 99-128. doi: 10.1207/s15327906mbr3901_4
- MacKinnon, D.P, Fritz, M.S, Williams, J., Lockwood, C.M. (2007). Distribution of the product confidence limits for the indirect effect: Program PRODCLIN. *Behavioral Research Methods*, 39, 384–389. doi: 10.3758/BF03193007
- McAdams, D.P. (1995). What do we know when we know a person? *Journal of Personality*, 63, 365-396. doi: 10.1111/j.1467-6494.1995.tb00500.x
- McAdams, D. P. (1999). Personal narratives and the life story. In L. Pervin & O. John (Eds.), *Handbook of personality: Theory and research*, 2nd Ed., pp. 478-500. New York: Guilford Press.
- Maxwell, S. E., & Cole, D. A. (2007). Bias in cross-sectional analyses of longitudinal mediation. *Psychological Methods*, 12, 23-44. doi: 10.1037/1082-989X.12.1.23
- Mesquita, B., & Frijda, N.H. (1992). Cultural variations in emotions: A review. *Psychological Bulletin*, 112, 179 –204. doi: 10.1037/0033-2909.112.2.179
- Murray, S.L., Holmes, J.G., Griffin, D.W., Bellavia, G., Rose, P. (2001). the mismeasure of love: how self-doubt contaminates relationship beliefs. *Personality and Social Personality Bulletin*, 27, 423-436. doi: 10.1177/014616720127400
- Muthén, L., & Muthén, B. (2006). *Mplus User's Guide*. Muthén & Muthén, Los Angeles, CA.
- Olson, S.L, Schilling, E.M, Bates, J.E. (1999). Measurement of impulsivity: construct coherence, longitudinal stability, and relationship with externalizing problems in middle childhood and

- adolescence. *Journal of Abnormal Child Psychology*, 27, 151–165.
doi:10.1023/A:1021915615677
- Rothbart, M.K., Ahadi, S.A., & Evans, D.E. (2000). Temperament and personality: Origins and outcomes. *Journal of Personality and Social Psychology*, 78, 122-135. doi: 10.1037/00223514.78.1.122
- Rothbart, M. K., & Bates, J. E. (2006). Temperament. In W. Damon, R. Lerner, & N. Eisenberg (Eds.), *Handbook of Child Psychology: Social, Emotional, and Personality Development* Vol. 3, 6th ed., pp. 99–166. New York: Wiley.
- Russell, J. A., & Carroll, J. M. (1999). On the bipolarity of positive and negative affect. *Psychological Bulletin*, 125, 3–30. doi: 10.1037/0033-2909.125.1.3
- Saarni, C. (1999). *The development of emotional competence*. New York: The Guilford.
- Schwarzer, R. (1996). Thought control of action: Interfering self-doubts. In I. Sarason, G. Pierce, & B. Sarason (Eds.), *Cognitive Interference*. Hillsdale, NJ: Erlbaum.
- Tanaka, J.S. (1993). Multifaceted conceptions of fit in structural equation models. In K. A. Bollen & J. S. Long (Eds.), *Testing structural equation models*, pp.10–39. Newbury Park, CA:Sage.
- Taylor, Z. E., Eisenberg, N., Spinrad, T. L., & Widaman, K. F. (2013). Longitudinal relations of intrusive parenting and effortful control to ego-resiliency during early childhood. *Child Development*. Online publication. doi: 10.1111/cdev.12054
- Vecchione, M., Alessandri, G., Barbaranelli, C., Gerbino, M. (2010). Stability and change of ego-resiliency from Late adolescence to young adulthood: A multiperspective Study Using the ER89–R Scale. *Journal of Personality Assessment*, 92, 1-10.
doi:10.1080/00223891003670166
- Watson, D., & Tellegen, A. (1985). Toward a consensual structure of mood. *Psychological Bulletin*, 98, 219–235. doi: 10.1037/0033-2909.98.2.219

CHAPTER III The predictive role of Ego-Resiliency in Behavioral Problems

1. Introduction

Research findings accumulated over the years suggest that ego-resiliency is a protective factor able to counter negative life outcomes in important behavioral domains (Block & Block, 2006). Empirical studies have found that low ego-resiliency during adolescence predicted poor adjustment (Block, Block & Keyes, 1988), undermined personality maturity, predicted later internalizing and externalizing problems and depressive symptoms (Block & Gjerde, 1990; Chuang, Lamb & Hwang, 2006; Huey & Weisz, 1997; Ong, Bergerman, Bisconti & Wallace, 2006; Westenburg & Block, 1993), while high ego-resiliency in adolescence was related to adaptation and positive development (e.g. Graber, Brooks-Gunn, & Peterson, 1996).

Despite the fact that previous research has identified numerous correlates of ego-resiliency, there is a lack of empirical studies addressing the directions of influence between ego-resiliency and behavioral problems. Indeed, previous studies mostly relied on cross-sectional research (e.g., Hofer, Eisenberg & Reiser, 2010) or clinical samples (Huey & Weisz, 1997) to investigate the role of ego-

resiliency on behavioral problems. We retain that clarifying the likely direction of influence between ego-resiliency and internalizing/externalizing problems during early adulthood is a critical question. Influential theoretical models depict ego-resiliency as a relatively broad and unconditional disposition (see, Asendorpf & Denissen, 2006) that exerts a pervasive influence on the individual's ability and behavior. One may therefore expect a direct effect from ego-resiliency on several indicators of adjustment in young adulthood. This implies that improving ego-resiliency could have a beneficial effect on several adaptive outcomes. A different causal mechanism, by contrast, would bring into question the usefulness of educational practices and intervention aimed at sustaining ego-resiliency.

In this study we used three waves of data collected from a sample of early adults aged from 20 to 29 years to examine the longitudinal relations of ego-resiliency with internalizing and externalizing problems. In this study, we strove to corroborate theoretical claims positing ego-resiliency as one of the key determinants of adjustment in this taxing developmental age (Arnett, 2000).

2. Relation between Ego-Resiliency and Behavioral Problems

Across all life stages, ego-resiliency has been associated with high intellectual capacities (Block & Kremen, 1996) and social competences (Spinrad et al., 2007), high levels of culturally desirable traits (Block, 1971; Taylor, Eisenberg, Spinrad, Eggum, & Sulik, in press; Ozer & Gjerde, 1989), and low levels of undesirable traits such as neuroticism, hostility, internalizing and externalizing problems (Causadias, Salvatore & Sroufe, 2012; Chuang, Lamb & Hwang, 2006; Eisenberg et al., 2004; Hofer et al., 2010; Letzring et al., 2005). Accordingly, ego-resilient individuals (i.e., individuals high in ego-resiliency) are likely to exhibit better adjustment and higher attainment than ego-brittle individuals (i.e., individuals low in ego-resiliency; also see Robins, John, Caspi, Moffitt, & Stouthamer-Loeber, 1996) and are believed to actively shape the world and make their environment more compatible with their personality due to their ability to

cope with changing environmental circumstances (Asendorpf & van Aken, 1999; Block & Block, 2006; Caspi & Silva, 1995).

Building on previous research, cross-sectional studies have revealed that ego-resiliency was negatively related to both internalizing and externalizing problems (Huey & Weisz, 1997) indicating the consistent relevance of this personality dimension to both forms of behavior problems in the children. Brittle individuals possessed lower levels of adaptive capabilities than resilient individuals, were more likely to respond unfavourably to various environmental stressors (Block & Block, 1980) and were more likely express themselves in either externalizing (i.e. drug abuse; Block et al, 1988) or internalizing (i.e. depressive symptomatology; Block & Gjerde, 1990) directions. With increasing levels of ego-resiliency, the likelihood that a child would express impulses in an externalizing or internalizing direction appeared to be significantly reduced. Of interest, whereas ego-resiliency and behavioral problems have been established as constructs related to children's adaptive social and psychological functioning (Eisenberg, et al. 2004; Martel, et al. 2007), little is known about their relations in populations other than young children and adolescents. Therefore the years of young adulthood are important for studying relations between personality and significant life outcomes (Krueger, 1999). In particular, the transition to adulthood is when depressive personality problems emerge, seriously compromising one's ability to make good personal choices, create good interpersonal relationships (Tanner et al., 2007; Paradis, Reinherz, Giaconia, & Fitzmaurice, 2006) and work productively (Wittchen, Nelson, & Lachner, 1998), compromising future adjustment. This result is mainly true for females (Keiley et al, 2000; Verhulst, 1995). In addition, during this phase there is an average reduction in antisocial problems that usually peak in adolescence (Bongers, Koot et al, 2003; Verhulst, 1995; Keenan & Shaw, 1997; Silverthorn & Frick, 1999).

Based on literature, we tested the relation between these three constructs longitudinally, assuming that during the period of emerging adulthood ego-resiliency can be a protective factor against maladjustment outcomes, especially behavioral aspects.

3. The present study

Although the above literature demonstrates that negative relations exist between ego-resiliency and behavioral problems, researchers previously have focused primarily on children, leaving questions about the nature of these associations in adolescence. It is possible that the association between ego resiliency and internalizing/externalizing problems changes at critical transition points in development such as early adulthood.

In this study we aimed to investigate the unidirectional flow of influences stemming from ego-resiliency to externalizing and internalizing problems using three waves of data gathered during the transition from late adolescence (age 20-21) to adulthood (age 28-29), using a cross-lagged panel design (Cole & Mazwell, 2003). Whereas not expected, we also investigated the reverse longitudinal path, from behavioral problems to ego-resiliency, to test if the presence of psychopathological symptoms can strengthen or decrease ego-resiliency during early adulthood.

4. Method

4.1. Participants

The participants were from families involved in the same ongoing longitudinal research presented in Studies 1 and 2.

One hundred and forty four young adults (59.7% female) were included in the first cohort (cohort 1 – C1). They were 20 years old in 2004 (i.e. Time 1-T1), 24 years old in 2008 (i.e. Time 2-T2) and 28 years old in 2012 (i.e. Time 3-T3). One hundred and nineteen young adults (48.7% female) were included in the second cohort (cohort 2-C2). They were 21 years old in 2004 (i.e. T1), 25 years old in 2008 (i.e. T2) and 29 years old in 2012 (i.e. T3). Cohort effects were previously tested and found to be insignificant for sociodemographic and major study variables. Therefore the data from the two cohorts were combined. About half of the participants were college students at each assessment (56.3% at T1, 54.8% at T2 and 44.1% T3). Seventy-two percent reported to be working at T3, but only 43.9% had an open-ended contract (30.3% full time and 13.6% part time).

At the last assessment, 71.8% of the participants were unmarried whereas 13.6% were married and 14.5% were cohabitant. Only 6% of the participants had children.

4.1.1. Attrition and missing data analysis

For C1, data was available for 89 individuals at Time 2 and 61 individuals at Time 3. For C2, data was available for 78 individuals at Time 2 and 51 individuals at Time 3. Overall, 42.6% of the original sample remained and contributed data at the final assessment time (2012). The attrition was mainly due to the individuals' inavailability to take part in this phase of the study. In some cases, the participants were uncontactable. Analyses of variance suggested that the participants included in the final sample at the later assessment (T3) did not differ significantly from their counterparts (participants not included at the last time) in the means and the covariances of the examined variables (demographics variables, ego-resiliency, internalizing and externalizing problems), as tested by a multivariate analysis of variance and *Box-M* test for homogeneity of covariance matrices. In sum, the attrition did not seem to be systematic.

The lack of selective attrition in our data is supported by Little's test (Little & Rubin, 2002) for data missing completely at random (MCAR) as implemented in SPSS 14. This test resulted in a nonsignificant value (i.e., $\chi^2 = 35.110$, $df = 29$; $p = .20$), indicating that missingness was related to the observed values of the variables in the data set, but unrelated to unobserved missing values (Enders, 2010). Accordingly, we computed the maximum-likelihood estimates of missing data via the expectation-maximization (EM) algorithm that restored the complete data matrix and offered unbiased estimates of missing data under MCAR assumption (Enders, 2010). The final sample size for this study was 263 (119 males and 144 females).

4.2. Procedure

All the procedures used in the longitudinal study were the same as the previous studies and are described better in the previous chapters (see Chapter I and II).

4.3. Measures

Ego-Resiliency. Ego-resiliency was measured using the 10 items of the Italian version of the Ego-Resiliency –Revised 89 (Alessandri et al., 2008; Vecchione et al. 2010). This scale is a brief inventory to assess an individual’s capacity of responding flexibly to challenging and shifting circumstances. Participants were asked to indicate the degree to which they agreed with each statement on a scale ranging from 1 (*never*) to 7 (*always*). High correlations with the original measure devised by Block and Kremen (1996) have confirmed the construct validity of the scale. The psychometric properties of the instrument have been documented in a large sample of Italian respondents (Alessandri et al., 2008) and confirmed in both cross-cultural and longitudinal research (Alessandri, Vecchione, Letziring, & Caprara, 2012; Vecchione et al., 2010). Sample items include “I quickly get over and recover from being startled,” “I get over my anger at someone reasonably quickly,” and “I am more curious than most people” (alphas = .78, .77, and .73, from T1 to T3, respectively).

Behavioral problems. Behavioral problems of participants were measured with the Adult Self-Report (ASR; Achenbach, 1997). This instrument is the adult equivalent of the YSR (Young Self-Report). It is a questionnaire for adults from 18 to 59 years old that includes 123 items covering behavioral or emotional problems that occurred during the past six months. The items (0=*not true*, 1=*somewhat or sometimes true*, and 2=*very true or often true*) are designed to tap two dimensions: internalizing problems (i.e., *withdrawal, somatic complaints, anxiousness/depression*), and externalizing problems (i.e., *delinquency and aggressive behaviour*). Alpha coefficients were .92, .92 and .93 from T1 to T3 for the internalizing scale, and .88, .85 and .88 from T1 to T3 for the externalizing scale.

Control variables. The following variable was included in analyses: sex (1 = males, 0 = females).

4.4. Statistical Analyses

To estimate the hypothesized model and handle missing data, we used *Mplus 5.01* (Muthén & Muthén, 2006) with Full Information Maximum Likelihood (FIML) estimation. Compared to other methods for handling missing data, such as listwise or pairwise deletion, FIML produces more reliable estimates for parameters and model fit (Enders & Bandalos, 2001).

To evaluate model fit for autoregressive cross-lagged models, the following criteria were employed: χ^2 likelihood ratio statistic, Tucker and Lewis Index (*TLI*), Comparative Fit Index (*CFI*), and the Root Mean Square Error of Approximation (*RMSEA*) with associated confidence intervals. The significance value of chi-square is sensitive to large sample sizes and easily produces a statistically significant result (Kline, 1998). We accepted *TLI* and *CFI* values greater than or equal to .95 (Hu & Bentler, 1999) and *RMSEA* values lower than or equal to .06 (Browne & Cudeck, 1993). To test for differences in fit among nested models, we calculated the chi-square difference test ($\Delta\chi^2$; see Bollen, 1989).

Finally, with regard to autoregressive cross-lagged models, we conducted multigroup analyses by cohort. We also used sex as a control variable in the model.

5. Results

5.1. Descriptive Statistics

Table 1 presents the means and standard deviations of ego-resiliency and both behavioral problems at T1, T2, and T3 and one-way analyses of variance (ANOVA) that evaluated gender differences in the considered variables. ANOVA indicated that there were significant gender differences only for internalizing problems. Females experienced more problems such as anxiety and depression than males throughout the study.

Table 2 presents the zero-order correlations among the observed variables (i.e., ego-resiliency, internalizing and externalizing problems) for both sexes. As expected, ego-resiliency and both behavioral aspects were negatively and significantly related, both concurrently and across time.

The examined variables also proved to be highly stable over time. In addition, the correlation was stronger for females than for males.

Table 1. Mean, Standard Deviation and Sex Differences for Ego-Resiliency and Internalizing/Externalizing Problems at each of the four Assessments for Males and Females

Variable	Males		Females		Sex	
	M	SD	M	SD	F (1, 263)	Sign.
Ego-resiliency T1	4.89	.77	4.85	.74	.14	.71
Internalizing T1	.27	.23	.41	.27	21.17**	.000
Externalizing T1	.34	.26	.34	.20	.01	.92
Ego-resiliency T2	5.11	.71	4.94	.80	2.16	.14
Internalizing T2	.24	.20	.39	.27	14.61**	.000
Externalizing T2	.26	.20	.31	.18	2.93	.09
Ego-resiliency T3	5.07	.72	4.91	.67	1.48	.23
Internalizing T3	.21	.23	.36	.29	7.13**	.01
Externalizing T3	.22	.21	.29	.19	2.95	.09

Note. ** $p < .05$. T1 = variable assessed at Time 1; T2 = variable assessed at Time 2; T3 = variable assessed at Time 3. F = F ratio resulting from one-way analyses of variance; the degrees of freedom and the number of participants are within the parentheses.

Table 2. Zero-order Correlations among Measures of Ego-Resiliency and Internalizing and Externalizing Problems for Males and Females.

	Res T1	Res T2	Res T3	Int T1	Int T2	Int T3	Ext T1	Ext T2	Ext T3
Res T1	1	.60**	.57**	-.24**	-.32*	-.32**	-.22**	-.20*	-.22*
Res T2	.58**	1	.75**	-.24**	-.26**	-.45**	-.15*	-.16*	-.36**
Res T3	.58**	.72**	1	-.21*	-.20*	-.34**	-.27**	-.27*	-.37**
Int T1	-.34**	-.32**	-.43**	1	.76**	.64**	.72**	.60**	.47**
Int T2	-.20*	-.46**	-.39*	.44**	1	.78**	.52**	.64**	.41**
IntT3	-.10	-.51**	-.37**	.28*	.81**	1	.53**	.56**	.66**
Ext T1	-.16*	-.28*	-.40**	.68**	.24*	.13*	1	.73**	.65**
Ext T2	-.20*	-.33**	-.35*	.29*	.75**	.65**	.36**	1	.67**
Ext T3	-.01	-.33*	-.17	.16*	.66**	.79**	.24*	.77**	1

Note. The correlation coefficients below the diagonal are for males and the correlation coefficients above the diagonal are for females. T1 = variable assessed at Time 1; T2 = variable assessed at Time 2; T3 = variable assessed at Time 3. Res = Ego-Resilience; Int = Internalizing problems; Ext = Externalizing problems. ** $p < .01$; * $p < .05$.

5.2. Modeling Strategies

We tested our theoretical model using a three-wave mediational design. In particular, as illustrated in Figure 1, the model included (a) all the autoregressive paths (which reflect inter-individual rank order stability over time in the variables), the across-time paths from (b) ego-resiliency at a given time to internalizing problems at the subsequent time point; (c) internalizing problems at a given time to ego-resiliency at the subsequent time point; (d) ego-resiliency at a given time to externalizing problems at subsequent time point and (e) externalizing problems at a given time to ego-resiliency at a subsequent time point. In addition, all the variables were allowed to covary within time (Cole & Maxwell, 2003). Control variable (sex) was included in relation to all variables and retained if they were significant ($p < .05$). This allowed us to test the likely direction of effects among constructs because cross-lagged paths reflected across-time effects controlling for prior levels of a construct.

The models were tested within a multiple group framework. This approach allowed us to ascertain if the results were the same across the two cohort. In performing the analyses, we started by estimating the fit of an *unconstrained model*, in which all the parameters were freely estimated across cohort and time. Then we specified a *time constrained model*, in which all the parameters were constrained to be invariant across time *but not* across cohort. In this way, we could assess any difference related to specific ages by examining the strength of the associations between the two constructs (Cole & Maxwell, 2003). Finally, we estimated a *time*cohort constrained model*, in which all the parameters were constrained to be invariant across time *and* across cohorts.

Figure 1. Autoregressive cross-lagged models of the relations between ego-resiliency, internalizing and externalizing problems. The relation between factors are specified as cross-lagged effects.

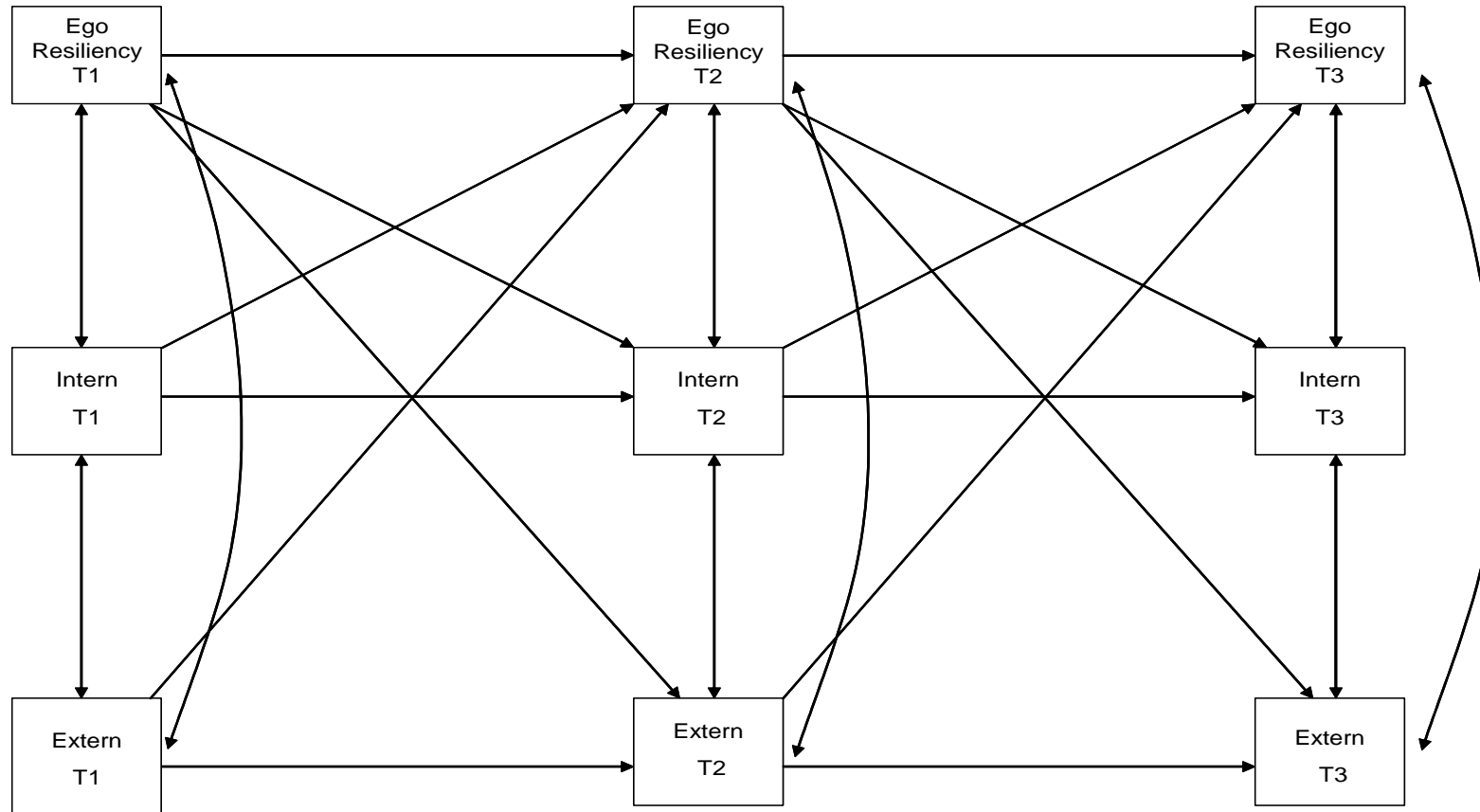

5.3. Longitudinal modeling

The fit of the *unconstrained model* was adequate: $\chi^2(26) = 35.21, p = .11$; CFI = .990; TLI = .965; RMSEA = .052 (CI 90% = .000-.092); SRMR = .048.

We then examined the invariance of parameters by constraining them to equality across time but not across groups (*time constrained model*). This allowed us to determine if there were significant differences in the effects of our constructs at different time points. However, constraining all the correlational, stability, cross-lagged and covariates paths resulted in a significant change of fit: $\Delta\chi^2(32) = 54.41, p = .01$. In this regard, we found that chi-square change was not significant ($\Delta\chi^2(28) = 33.15, p = .23$) if equality constraints by cohort were lifted from the path leading from sex to internalizing problems. All the other constraints were retained in the model. Finally, we estimated a *time*cohort constrained model*, in which all the parameters were constrained to be invariant across time *and* across cohort. In this case, we found a non-significant change of fit: $\Delta\chi^2(12) = 20.64, p = .06$.

The final model (*the time*cohort constrained*) demonstrated an adequate fit to the data: $\chi^2(66) = 88.998, p = .03$; CFI = .974; TLI = .965; RMSEA = .051 (CI 90% = .016-.077); SRMR = .071. This best-fit model is displayed in Figure 2.

5.4. Autoregressive, Cross-lagged paths and Concurrent Relations

As shown in Figure 2, the variables were highly stable across the three time points: all the examined variables at T1 significantly predicted the same variables at T2, and so on for the subsequent time points. In addition, ego-resiliency negatively predicted internalizing problems across time, while there was a tendency to significance ($p = 0.08$) for externalizing problems. Most importantly, the opposite paths linking each outcome variable to ego-resiliency were not-significant. All of these longitudinal predictions held above and beyond the stability of the variables. Each variable was also significantly associated with the other two variables within time at all three time-points.

These results supported the hypothesis that higher levels of ego-resiliency in emerging adulthood were predictive of a better psychological adjustment over time, especially in terms of lower levels of internalizing symptoms. Of importance, these effects held over time and across cohorts.

5.5. Effects of Covariates

Sex significantly and negatively predicted internalizing problems only at T1 ($\beta = -.17$, $SE = .03$, $p < .05$), with females scoring higher.

5.6. Variance Explained

The models accounted for a large proportion of variability in all the variables. Specifically, for first cohort R-squared at T2 were 39% for ego-resiliency, 53% for internalizing problems and 36% for externalizing problems; at T3, they were 68% for ego-resiliency, 51% for internalizing problems and 40% for externalizing problems; for second cohort R-squared at T2 were 47% for ego-resiliency, 53% for internalizing problems and 52% for externalizing problems; at T3, they were 46% for ego-resiliency, 59% for internalizing problems and 42% for externalizing problems.

5.7. Estimates of the Remaining Cross-lagged Paths

Finally, we ascertained if the remaining cross-lagged paths (i.e., from internalizing problems at T1 to externalizing problems at T2; from externalizing problems at T1 to internalizing problems at T2; from internalizing problems at T2 to externalizing problems at T3; and from externalizing problems at T2 to internalizing problems at T3) significantly improved the fit of the hypothesized model. As indicated by the chi-square difference test for nested models, $\Delta\chi^2(8) = 13.18$, $p = .106$, the change was not significant. The chi-square difference test was also non-significant when we tested each of these parameters one at a time.

Figure 2. Longitudinal relations between individuals' Ego-Resiliency, Internalizing and Externalizing problems assessed at T1, at T2, and T3 in the *time*group constrained model*.

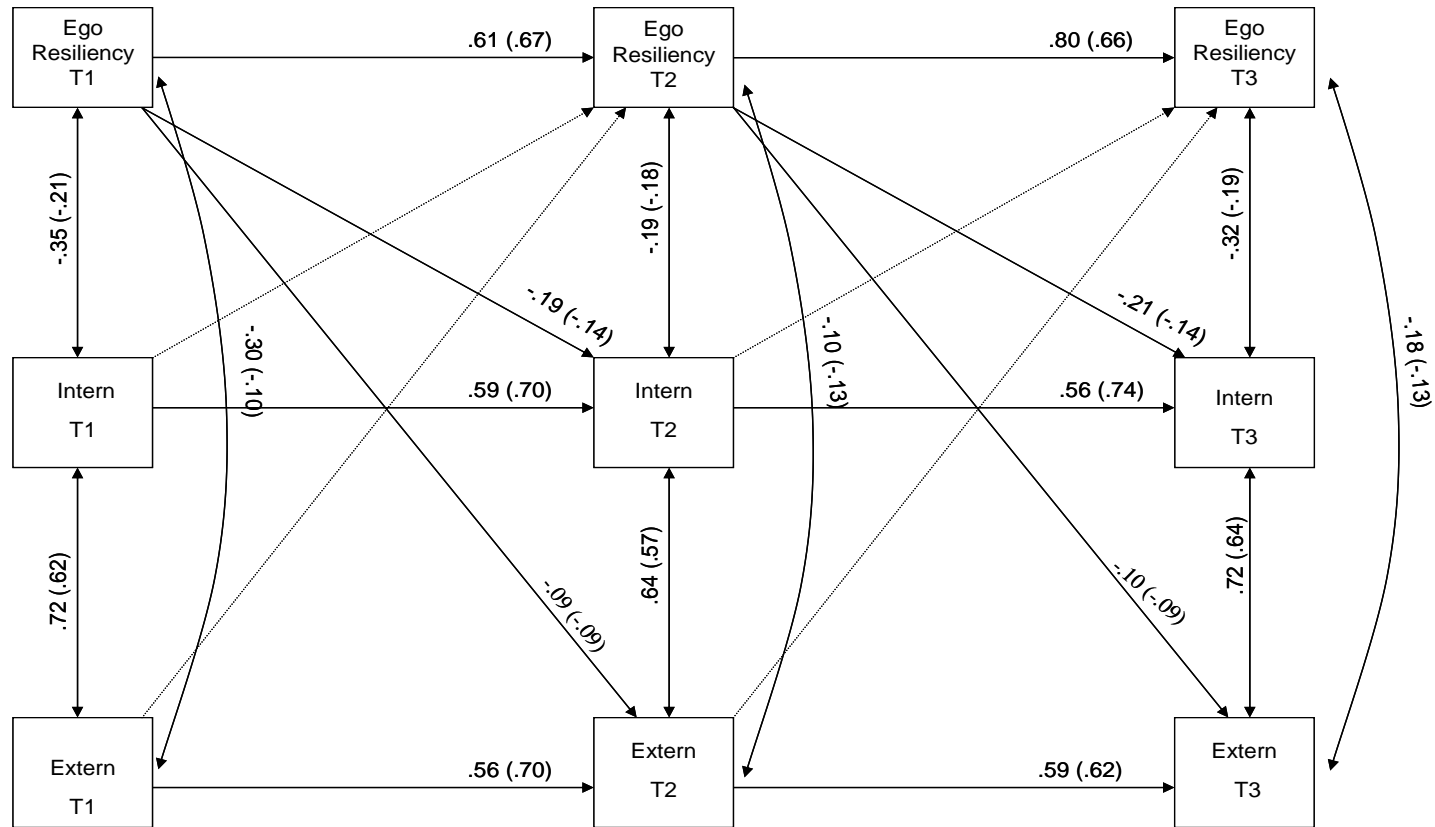

Note. Solid lines represent significant paths. Reported coefficients refer to standardized estimates for first and for second group (in parentheses), respectively. For simplicity we omitted the effects of sex. Parameters are significant beyond $p < .05$. The path from ego-resiliency to externalizing problems tended to significance ($p = .08$)

6. Discussion

Ego-resiliency has usually been considered as a stable dimension of personality that can promote individual adaptation in important psychological domains during different developmental phases (Block & Block, 2006). Yet, previous researchers have rarely focused simultaneously on the beneficial effects of ego-resilient people on relevant indicators of psychological adjustment such as depression and abuse of substance. In the present study, in order to offer a compelling picture of the role of ego-resiliency, we analyzed its effect on behavioral domain in terms of internalizing and externalizing problems. In particular, in the present study we examined the reciprocal relations between these variables during the period of early adulthood (from 20 to 29 years). We considered this developmental phase because it represents a transitional life period that requires adjustment to many psychological and environmental changes (e.g., Arnett, 2000; Graber, Brooks-Gunn, & Petersen, 1996), such as going away to college or starting a job, living independently or outside of the parental home, or moving in with a romantic partner. As argued previously (Breunlin, 1988), these experiences might disrupt the previous equilibrium of an adolescent's ecological system. Indeed, young adults are expected to become more independent and start searching for their place in society (Arnett, 2000).

As expected, results confirmed the primacy role of ego-resiliency in influencing adjustment. As it stands we were able to confirm our expectation of a significant prediction of internalizing and externalizing problems from ego-resiliency over time. Results showed that ego-resiliency had important counteracting effects particularly on internalizing behavioral problems during the early adulthood. In particular, ego-resiliency predicted lower levels of internalizing problems. These results were in part consistent with literature (Block & Gjerde, 1990). Indeed, individuals who possessed high levels of adaptive capabilities and who responded favorably to various environmental stressors (higher in ego-resiliency) were more likely to have a positive attitude towards adverse situations (Yu & Zhang, 2007), be not only less susceptible to anxiety but also successfully and positively engaged with the world (Block & Kremen, 1996; Tellegen, 1985). On

the contrary, individuals with low levels of ego-resiliency were more likely to be prone to experiencing high levels of anxiety and negative emotionality and therefore be less controlled in responding to environmental stimuli (Block & Block, 1980). They were also more likely to express both externalizing (i.e. drug abuse; Block et al, 1988) and internalizing (i.e. depressive symptomatology; Block & Gjerde, 1990) symptoms. It is noteworthy that the effect of ego-resiliency on internalizing and externalizing problems emerge despite the high stability of internalizing and externalizing problems and their high correlations

Of interest was that in the present study we found only a tendency to significance on path from ego-resiliency to externalizing problems. Within this light, the marginal significance of ego-resiliency on externalizing problems has a powerful values especially taking into account that externalizing problems decrease in adulthood. Anyway, it seems likely that the uncovered pattern of relations can be attributed to the specific time frame investigated. However, all these results were consistent with Block and Kremen's definition (1996) that considered ego-resiliency as a trait able to influence personal and social functioning in diverse phases of development (Borgers, Koot et al, 2003).

Compared to relevant prior studies (e.g., Huey & Weisz, 1997; Block & Gjerde, 1990), the present work is novel in several aspects. First, we examined the relevant relations with longitudinal data across five years rather than with cross-sectional data (e.g., Huey & Weisz, 1997). Second, we considered a community and not clinical sample. Third, we addressed the years of the transition to early adulthood, which has received little attention in the literature on externalizing and internalizing problems.

In spite of the number of strengths, we recognize some potential limitations of this study. First of all, it is necessary to test the generalizability of our findings across different populations and in cultural contexts other than Italy. Indeed, ego-resiliency and the various outcomes may show important variations across social context and cultures. In addition, although our data was longitudinal, it could not prove causality. Moreover, we only used self-reported measures for our

constructs. Since they were all based on the same method, the results were artificially inflated by shared method variance (Kline, 2010). Therefore, future research should aim to include other informant-based measures (e.g., other reports, behavioral measures).

Notwithstanding these limits, we believe that the present research will contribute to the understanding of the positive effect of ego-resiliency in predicting various important life outcomes (Block & Block, 1980). In order to increase our knowledge on this important domain, future research should examine whether ego-resiliency can influence well-being and success in other domains such as work, relationship, health, etc.

References

- Achenbach, T. M. (1997). *Manual for the young adult self-report and young adult behavior checklist*. Burlington, VT: University of Vermont Department of Psychiatry.
- Alessandri, G., Vecchio, G., Steca, P., Caprara, M. G., & Caprara, G. V. (2008). A revised version of Kremen and Block's ego-resiliency scale in an Italian Sample. *Testing, Psychometrics, Methodology in Applied Psychology*, 14, 1-19. doi: 10.1027/1015-5759/a000102
- Alessandri, G., Vecchione, M., Letziring, T., Caprara, G. V. (2012). The ego-resiliency scale revised: A cross-cultural study in Italy, Spain, and the United States. *European Journal of Psychological Assessment*, 28, 139-146. doi: 10.1027/1015-5759/a000102
- Arnett, J. J. (2000). Emerging adulthood: A theory of development from the late teens through the twenties. *American Psychologist*, 55, 469-480. doi: 10.1037/0003-066X.55.5.469
- Asendorpf, J. B., & van Aken, M. A. G. (1999). Resilient, over-controlled, and undercontrolled personality prototypes in childhood: Replicability, predictive power, and the trait-type issue. *Journal of Personality and Social Psychology*, 77, 815–832. doi: 10.1037/0022-3514.77.4.815
- Asendorpf, J. B. & Denissen, J. J. A. (2006). Predictive validity of personality types versus personality dimensions from early childhood to adulthood: Implications for the distinction between core and surface traits. *Merrill-Palmer Quarterly*, 52, 486-513. doi:10.1353/mpq.2006.0022
- Block, J. (1971). *Lives through time*. Berkeley, CA: Bancroft Book.
- Block, J. H., & Block, J. (1980). The role of ego-control and ego-resiliency in the organization of behavior. In W. A. Collins (Ed.), *Minnesota symposia on child psychology*, Vol 13, pp. 39–101. Hillsdale, NJ: Erlbaum.
- Block, J., Block, J. H., & Keyes, S. (1988). Longitudinally foretelling drug usage in adolescence: Early childhood personality and environmental precursors. *Child Development*, 59, 336–355. doi: 10.2307/1130314

- Block, J. H., & Gjerde, P. F. (1990). Depressive symptoms in late adolescence: A longitudinal perspective on personality antecedents. In J. Rolf, A. S. Masten, D. Cicchetti, K. H. Nuechterlein & S. Weintraub (Eds.), *Risk and protective factors in the development of psychopathology* (pp. 334-360). New York: Cambridge University Press.
- Block, J. H., & Kremen, A. M. (1996). IQ and ego-resiliency: Conceptual and empirical connections and separateness. *Journal of Personality and Social Psychology*, 70, 349-361. doi: 10.1006/jrpe.2001.2344
- Block, J. H., & Block, J. (2006). Venturing a 30-year longitudinal study. *American Psychologist*, 61, 315-327. doi: 10.1037/0003-066X.61.4.315
- Bollen, K.A. (1989). Structural equations with latent variables. New York: John Wiley & Sons, Inc.
- Bongers, I. L., Koot, H. M., van der Ende, J., & Verhulst, F. C. (2003). The normative development of child and adolescent problem behavior. *Journal of Abnormal Psychology*, 112, 179–192. doi:10.1037/0021-843X.112.2.179
- Breunlin, D. C. (1988). Oscillation theory and family development. In C. Falicov (Ed.), *Family transition* (pp. 133-155). New York: The Guilford Press.
- Browne, M. W. & Cudeck, R. (1993). Alternative ways of assessing model fit. In K. A. Bollen, & S. J. Long (Eds). *Testing structural equation models* (pp. 137-162). Newbery Park: Sage.
- Caprara, G. V., Scabini, E., Barbaranelli, C, Pastorelli, C, Regalia, C, & Bandura, A. (1998). Impact of adolescents' perceived self-regulatory efficacy on familial communication and antisocial conduct. *European Psychologist*, 3, 125-132. doi: 10.1027//1016-9040.3.2.125
- Caprara, G. V., Steca, P., Zelli, A., Capanna, C. (2005). A new scale for measuring adults prosocialness. *European Journal of Psychological Assessment*, 21, 77-89. doi:10.1027/1015-5759.21.1.77
- Caspi, A., & Silva, P. A. (1995). Temperamental qualities at age three predict personality traits in young adulthood: Longitudinal evidence from a birth cohort. *Child Development*, 66, 486-498. doi: 10.1111/j.1467-8624.1995.tb00885.x

- Causadias, J. M., Salvatore, J. E., & Sroufe, L. A. (2012). Early patterns of self-regulation as risk and promotive factors in development: A longitudinal study from childhood to adulthood in a high-risk sample. *International Journal of Behavioral Development*. doi:10.1177/0165025412444076
- Chuang, S. S., Lamb, M. E., & Hwang, C. P. (2006). Personality development from childhood to adolescence: A longitudinal study of ego-control and ego-resiliency in Sweden. *International Journal of Behavioral Development*, 30, 338 - 343. doi: 10.1177/0165025406072795
- Cole, D. A., & Maxwell, S. E. (2003). Testing mediational models with longitudinal data: Questions and tips in the use of structural equation modeling. *Journal of Abnormal Psychology*, 112, 558–577. doi: 10.1037/0021-843X.112.4.558
- Eisenberg, N., Spinrad, T. L., Fabes, R. A., Reiser, M., Cumberland, A., Shepard, S. A., ... Thompson, M. (2004). The relations of effortful control and impulsivity to children's resiliency and adjustment. *Child Development*, 75, 25–46.
- Enders, C. K., & Bandalos, D. L. (2001). The relative performance of full information maximum likelihood estimation for missing data in structural equation modeling. *Structural Equation Modeling*, 8, 430-457. doi: 10.1207/S15328007SEM0803
- Enders, G. (2010). *Applied missing data analysis*. New York: The Guildford press.
- Graber, J. A., Brooks-Gunn, J., & Petersen, A. C. (1996). Adolescent transitions in context. In J. A. Graber, J. Brooks-Gunn, & A. C. Petersen (Eds.), *Transitions through adolescence: Interpersonal domains and context* (pp. 369-383). Mahwah, NJ: Erlbaum.
- Keenan, K., & Shaw, D. (1997). Developmental and social influences on young girls' early problem behaviors. *Psychological Bulletin*, 121, 95–113. doi: 10.1037/0033-2909.121.1.95
- Keiley, M. K., Bates, J. E., Dodge, K. A., & Pettit, G. S. (2000). A cross-domain growth analysis: Externalizing and internalizing behaviors during 8 years of childhood. *Journal of Abnormal Child Psychology*, 28, 161–179. doi:10.1023/A:1005122814723

- Kline, R. B. (1998). *Principles and practices of structural equation modeling*. New York: Guilford.
- Kline, R. B. (2010). *Principles and practices of structural equation modeling, third edition (Methodology in the social sciences)*. New York: The Guildford press.
- Krueger, R.F. (1999). Personality traits in late adolescents predicts mental disorders in early adulthood: A prospective-epidemiological study. *Journal of Personality*, 67, 39-65. doi: 10.1111/1467-6494.00047
- Hofer, C., Eisenberg, N., & Reiser, M. (2010). The role of socialization, effortful control, and ego-resiliency in French adolescents' social functioning. *Journal of Research on Adolescence*, 20, 555-582. doi: 10.1111/j.1532-7795.2010.00650.x
- Hu, L., & Bentler, P. M. (1999). Cutoff criteria for fit indexes in covariance structure analysis: Conventional criteria versus new alternatives. *Structural Equation Modeling*, 6, 1-55. doi: 10.1080/10705519909540118
- Huey, S. J., & Weisz, J. R. (1997). Ego-control, ego-resiliency, and the five-factor model as predictors of behavioral and emotional problems in clinic-referred children and adolescents. *Journal of Abnormal Psychology*, 3, 404-415. doi: 10.1037/0021-843X.106.3.404
- Istituto Italiano di Statistica (2002). *Annuario statistico italiano 2002 [Italian yearbook of statistics 2002]*. Rome: ISTAT.
- Letzring, T. D., Block, J., & Funder, D. C. (2005). Ego-control and ego-resiliency: Generalization of self report scales based on personality descriptions from acquaintances, clinicians and the self. *Journal of Research in Personality*, 39, 395-422. doi: 10.1016/j.jrp.2004.06.003
- Little, R. J. A. & Rubin, D. B. (2002). *Statistical analysis with missing data*, 2nd edition, New York: John Wiley.
- Martel, M. M., Nigg, J. T., Wong, M. M., Fitzgerald, H. E., Jester, J. M., Puttler, L. I., ... Zucker, R. A. (2007). Childhood and adolescent resiliency, regulation, and executive functioning in relation to adolescent problems and competence in a high-risk sample. *Developmental Psychopathology*, 19(2), 541–563. doi: 10.1017/80954579407070265

- Muthén, L., & Muthén, B. (2006). *Mplus User's Guide*. Muthén & Muthén, Los Angeles, CA.
- Ong, A. D., Bergerman, C. S., Bisconti, T. L., & Wallace, K. A. (2006). Psychological resilience, positive emotions and successful adaptation in later life. *Journal of Personality and Social Psychology*, 91, 730-749. doi: 10.1037/a0024791
- Ozer, D. J., & Gjerde, P. F. (1989). Patterns of personality consistency and change from childhood through adolescence. *Journal of Personality*, 57, 483-507. doi: 10.1111/j.1467-6494.1989.tb00490.x
- Paradis, A. D., Reinherz, H. Z., Giaconia, R. M., Fitzmaurice, G. (2006). Major depression in the transition to adulthood: The impact of active and past depression on young adult functioning. *Journal of Nervous Mental Disorders*, 194(5), 318–323.
- Pastorelli, C., Caprara, G. V., Barbaranelli, C., Rola, J., Rozsa, S., & Bandura, A. (2001). The structure of children's perceived self-efficacy: A cross-national study. *European Journal of Psychological Assessment*, 17 (2), 87-97.
- Robins, R. W., John, O. P., Caspi, A., Moffitt, T. E., & Stouthamer-Loeber, M. (1996). Resilient, overcontrolled, and undercontrolled boys: Three replicable personality types. *Journal of Personality and Social Psychology*, 70, 157-171. doi: 10.1037/0022-3514.70.1.157
- Silverthorn, P., & Frick, P. J. (1999). Developmental pathways to antisocial behavior: The delayed-onset pathway in girls. *Development and Psychopathology*, 11, 101–126. doi:10.1017/S0954579499001972
- Spinrad, T. L., Eisenberg, N., Gaertner, B., Popp, T., Smith, C. L., Kupfer, A., ... & Hofer, C. (2007). Relations of maternal socialization and toddlers' effortful control to children's adjustment and social competence. *Developmental Psychology*, 43, 1170-1186. doi:10.1037/0012-1649.43.5.1170
- Tanner, J. L., Reinherz, H. Z., Beardslee, W. R., Fitzmaurice, G. M., Leis, J. A. & Berger, S. R. (2007). Change in prevalence of psychiatric disorders from ages 21 to 30 in a community sample, *Journal of Nervous and Mental Disease*, 195, 298-306.

doi:10.1097/01.nmd.0000261952.13887.6e.

- Taylor, Z. E., Eisenberg, N., Eggum-Wilkens, N. D., Sulik, M. J., & Spinrad, T. L. (in press). The relations of ego-resiliency and emotion socialization to the development of empathy and prosocial behavior across early childhood. *Emotion*. doi:10.1037/a0032894
- Tellegen A. (1985). Structures of mood and personality and their relevance to assessing anxiety, with an emphasis on self-report. In A. H. Tuma & J. Mason (Eds), *Anxiety and the Anxiety Disorders* (pp. 681-706), Hillsdale, N.J: Erlbaum.
- Vecchione, M., Alessandri, G., Barbaranelli, C., Gerbino, M. (2010). Stability and change of ego resiliency from late adolescence to young adulthood: A multiperspective study using the ER89-R scale. *Journal of Personality Assessment*, 92, 1-10. doi:10.1080/00223891003670166
- Verhulst, F. C. (1995). A review of community studies. In F. C. Verhulst, & H. M. Koot (Eds.), *The epidemiology of child and adolescent psychopathology* (pp. 146-177). London: Oxford University Press.
- Yu, X., Zhang, J. (2007). Factor analysis and psychometric evaluation of the Connor-Davidson resilience scale (CD-RISC) with Chinese people. *Social Behaviour and Personality*, 35, 19-30. doi:10.2224/sbp.2007.35.1.19
- Wittchen, H. U., Nelson, C. B., & Lachner, G. (1998). Prevalence of mental disorders and psychosocial impairment in adolescents and young adults. *Psychological Medicine*, 28, 109-126.
- Westenburg, P. M., & Block, J. (1993). Ego development and individual differences in personality. *Journal of Personality and Social Psychology*, 65, 792-800. doi: 10.1037/0022-3514.65.4.792

GENERAL CONCLUSION

The present work starts with a general analysis of the field of ego-resiliency, a marker of psychological resilience. We then shift our focus to two aspects of this construct which, in recent years, have found their way into literature and the practice of psychology and developmental psychology. The two aspects of ego-resiliency we considered were, on the one hand, its association with some indicators of psychological adjustment in adolescence and emerging adulthood and, on the other hand, the possibility of promoting ego-resiliency by fostering the development of a positive psychological trait, namely positive orientation. In particular, this work has mainly focused on an important developmental age that has been defined by Arnett (2004) as “emerging adulthood”. This is a period during which there is a strong potential for personality change. In fact one goes from being adolescent, at the mercy of his impulses, to feeling adult, with responsibilities deriving from the many life experiences that take place during this period (i.e. finishing college, starting a job, getting married, etc).

The first and the second study of this dissertation offer new insights on the relationship between ego-resiliency and on the main antecedents of this construct such as positive orientation and emotional self-efficacy beliefs. The results represent an important contribution to the design of

applied interventions aimed at fostering the development of resilience in youths. The first study in particular showed that positivity predicted ego-resiliency across time, while ego-resilience did not seem to predict positivity. These findings assign positivity an eminent role as a “dispositional” cause that promotes and sustains ego-resiliency. Subsequently, the second study indicated that self-efficacy beliefs in managing negative emotions and in expressing positive emotions were significantly associated with the development of ego-resiliency over time. The reciprocity observed between emotional self-efficacy beliefs and ego-resiliency suggests that experiencing oneself as an individual able to resourcefully adapt to changing circumstances and to environmental stressors provides the conditions for practising and further strengthening the abilities that from the basis of feeling efficacious. At the same time, emotional self-efficacy is likely to affect individuals’ ability to adapt and deal flexibly with difficult situations and enhance perseverance in the face of failure (Bandura et al., 2001). These qualities are relevant for the development of youths’ ego-resiliency. The findings obtained are therefore useful in designing interventions aimed at strengthening ego-resiliency as they suggest that even such a stable disposition may be amenable to change through appropriate experiences.

The third study that aims to understand the relationship between having many resilient qualities and successful adaptation in terms of behavioral problems has allowed us to confirm the protective role of this construct as defined by Block & Kremen (1996), as a trait that is able to influence personal and social functioning in diverse phases of development. During early adulthood, it seems that ego-resiliency has an important counteracting effect especially with regard to internalizing problems. This concurs with literature stating that during the transition from adolescence to adulthood depression or anxiety symptoms tend to increase while antisocial and delinquent problems tend to decrease with maturity. In addition, these results confirmed that individuals who possess high levels of adaptive capabilities and who respond favorably to various environmental stressors are more likely to have a positive attitude toward adverse situations (Yu & Zhang, 2007) and be less susceptible to anxiety (Block & Kremen, 1996; Tellegen, 1985). On the

contrary, individuals with low levels of ego-resiliency are more likely to be prone to experiencing high levels of anxiety, negative emotionality, and thus be less controlled in responding to environmental stimuli (Block & Block, 1980), and more likely to express both externalizing (i.e. drug abuse; Block et al, 1988) and internalizing (i.e. depressive symptomatology; Block & Gjerde, 1990) symptoms. The present work is new because it addresses the above relations during a developmental phase that has been rarely studied. In fact the previous studies were focused in early adolescence.

With regard to potential limitations of this work, first it would be desirable to test the generalizability of our findings across different populations. Second, the use of self-report data: all considered measures should take advantage of the use of more than a single informant (e.g., peer or family reports, behavioral measures). Third, it would be appropriate to study the ego-resiliency in more or less stressful life situations that take place during the years covered in the three studies. Notwithstanding these limits, this work intends to give an innovative and advanced contribution to the study of psychological resilience toward an integrated understanding of this construct, both theoretically and empirically, that can be used as an instrument to develop preventive intervention programs in various contexts. In particular, by considering resiliency as a relational construct, it would be possible to develop specific strategies for assessment and intervention, designed to support both the individual and the family in managing difficulties due to transitions at different stages of life as well as unexpected and potentially traumatic events.

References

- Arnett, J. J. (2004). *Emerging adulthood: The winding road from the late teens through the twenties*. New York: Oxford University Press.
- Bandura, A., Barbaranelli, C., Caprara, G.V., & Pastorelli, C. (2001). Self-efficacy beliefs as shapers of children's aspirations and career trajectories. *Child Development, 72*, 187–206. doi: 10.1111/1467-8624.00273
- Block, J.H., & Block, J. (1980). The role of ego-control and ego-resiliency in the organization of behavior. In W.A. Collins (Ed.), *Minnesota symposia on child psychology*, Vol 13, pp. 39–101. Hillsdale, NJ: Erlbaum.
- Block, J., Block, J. H., & Keyes, S. (1988). Longitudinally foretelling drug usage in adolescence: Early childhood personality and environmental precursors. *Child development, 336-355*. doi: 10.2307/1130314
- Block, J. H., & Gjerde, P. F. (1990). Depressive symptoms in late adolescence: A longitudinal perspective on personality antecedents. In J. Rolf, A. S. Masten, D. Cicchetti, K. H. Nuechterlein & S. Weintraub (Eds.), *Risk and protective factors in the development of psychopathology*, pp. 334-360. New York: Cambridge University Press.
- Block, J.H., & Kremen, A.M. (1996). IQ and Ego-resiliency: conceptual and empirical connections and separateness. *Journal of Personality and Social Psychology, 70*, 349-361. doi: 10.1006/jrpe.2001.2344
- Yu, X., Zhang, J. (2007). Factor analysis and psychometric evaluation of the Connor-Davidson resilience scale (CD-RISC) with Chinese people. *Social Behaviour and Personality, 35*, 19-30. doi:10.2224/sbp.2007.35.1.19
- Tellegen A. (1985). Structures of mood and personality and their relevance to assessing anxiety, with an emphasis on self-report. In A. H. Tuma & J. Mason (Eds), *Anxiety and the Anxiety Disorders* (pp. 681-706), Hillsdale, N.J: Erlbaum.

Acknowledgements

I wish to express my most sincere gratitude to my supervisor, Professor Gian Vittorio Caprara, who led me through the research world, who gave me confidence and determination, who believed in my potential not expressed yet, and who offered many motivating and stimulating experiences for my professional development.

To professor Concetta Pastorelli, for her practical and effective presence, for moments of shared humanity.

To Guido Alessandri, for his sensitivity, for his methodological and friendly advice, but, above all, for his ability to strengthen my psychological resilience when it was necessary.

To Maria Grazia Gerbino for her sensitivity and friendship, for her clear theoretical look.

I am thankful to all persons of CIRMPA, with whom we share the coffee, the close spaces of the laboratory, the reflections, but above all the friendship. Particularly, to Laura Di Giunta, Valeria Castellani and Paula Lungo Kanakri for their extreme availability and patience.

I sincerely thank to my “travel companions”: Antonio Zuffiano, Rosalba Ceravolo, Francesca Colaiaco, for the harmony, the laughter, the friendship and for their fantastic irony through which have made incredible every single day.

Finally, I would like to thank Professor Nancy Eisenberg who gave me the opportunity to visit her at Arizona State University, with whom I never imagined to work personally, for her excellent capability and preparation, for her immediacy.

THANKS TO ALL!!