

See discussions, stats, and author profiles for this publication at: <https://www.researchgate.net/publication/233814580>

Development of a HGV FEM for road safety analysis

Conference Paper · January 2004

CITATIONS

7

READS

343

3 authors:



Guido Bonin

Sapienza University of Rome

34 PUBLICATIONS 230 CITATIONS

[SEE PROFILE](#)



Giuseppe Cantisani

Sapienza University of Rome

83 PUBLICATIONS 860 CITATIONS

[SEE PROFILE](#)



Giuseppe Loprencipe

Sapienza University of Rome

137 PUBLICATIONS 1,465 CITATIONS

[SEE PROFILE](#)

Some of the authors of this publication are also working on these related projects:



Low-Cost Sensors for Road Condition Monitoring [View project](#)



Building Information Modeling (BIM): prospects for the development of Railway Infrastructure industry [View project](#)

DEVELOPMENT OF A HGV FEM FOR ROAD SAFETY ANALYSIS

Guido Bonin, Giuseppe Cantisani and Giuseppe Loprencipe

Università di Roma
"La Sapienza", Roma, Italy.

ABSTRACT

In the last years roadside safety design, in particular for passive systems, was greatly improved with the possibility to use computational mechanics.

Computational mechanics is based on the use of complex finite element codes, that allows the virtual reproduction of real world problems. Regarding roadside safety, the design phase was, until now, based on the use of simplified analysis, unable to describe accurately the complexity of vehicle impacts against safety hardware.

To build a FE model for an impact problem many elements are necessary:

- Model geometry.
- Constitutive laws of the materials.
- Links (rigid, cinematic, etc.) between bodies or part of them.
- Definition and characterization of contact surfaces.

This set of information is needed for each different body involved in the event; making the development of a complete model very much demanding, but once a part (subset) of the entire model has been accurately validated by the comparison with real experimental data, it can be used again and again in other analogous models.

Our goal was to build and validate a FE model of a Heavy Goods Vehicle (HGV).

We chose this kind of vehicle because it wasn't available and because it was useful to test the containment of the barriers, and to study the dynamic interactions between vehicle and road pavement.

In particular, this vehicle can be used to test the safety barriers according to EN 1317 standard, for the H4a class of containment. It reproduces a FIAT-IVECO F180 truck, a vehicle with 4 axles and a mass of 10.5 ton (30 with the full load).

The model (12337 elements and 11470 nodes) was built for and is ready to use with LS Dyna FE code from Livermore Software Technology Corporation.

Keywords: HGV FEM, barriers design, crash, passive safety

INTERNATIONAL RESEARCH TOPICS IN ROAD SAFETY THEMES

Road safety is a fundamental issue for the researchers dealing with vehicle and infrastructure design.

The large number of fatalities and injuries that occur every year on the roads demand special strategies including education and repression of the users' wrong behavior, road and automotive technology.

The European Community planned to reduce the number of injuries and fatalities in all the Member States by 40% in 2010. Recently the plan was updated and the target reduction is now 50%.

Road accidents are complex phenomena, with one or more impacts, that cause damage to the vehicle's passengers, because of the high acceleration and shocks to the sensible parts of the body. In these impacts many physical elements interact: the road, the vehicle, the roadside protection devices and other "external" elements (trees, poles, structures, etc.).

In the road safety analyses it is common to separate the "active safety" (the possibility to avoid road accidents) and "passive safety" (aimed to the reduction of the effects of an accident). Regarding the passive safety, road and vehicle researchers and designers try to propose solutions able to lower the effect of impacts (vehicle to vehicle or vehicle with other objects around the road), to reduce the injuries to the users.

In particular, researchers in automotive engineering try to create highly deformable and energy absorbing vehicle structures, but maintaining intact and avoiding all the intrusions in the central part. There are also auxiliary passive safety devices (like Airbags) to protect, during the impact, the vital parts from the collision with interior parts.

Researchers in infrastructure engineering focus their efforts in the safety performance of the road sides, to keep the vehicle in the carriageway and dissipating the impact energy. In this sense, the most interesting devices are the road restraint systems (or safety barriers). The results carried out in the last decades influenced the road standards, design and construction.

It is clear that there is a real interest in developing a common approach for vehicle and infrastructures: the analysis of impact phenomena and more in general the dynamic interactions among vehicle, road and road side elements. In this sense the most interesting possibilities were offered in the last years from the use of computational mechanics, which gives the possibility to virtually reproduce events that, due to their complexity, cannot be analyzed with standard traditional physical-mathematical methods. Besides, the development of computers gave a great impulse to the research, because it became possible to build and examine virtual models more and more complex, that have a good correlation with the real experiences.

In this paper is presented the development of a finite element model of a Heavy Goods Vehicle (HGV or lorry) that is an object of great interest in road safety research. The vehicle object of the study it is a very common heavy truck in Europe and it is very important because it is one of the vehicle used for the very high containment safety barriers acceptance test and there were no FE model available.

PRINCIPLES AND UTILITY OF COMPUTATIONAL MECHANICS FOR ROADSIDE SAFETY DESIGN

The study of complex dynamic events, like impacts, usually does not have a complete and satisfactory solution in the conventional theoretical models. This is because of the geometric and structural complexity of the single bodies and of the whole system, for the various and complex interactions.

For all these reasons, a good knowledge of impacts requires the executions of expensive real world tests. This reduces the possibilities of studying something really innovative and thus the possibility to raise the passive safety: the enhancements of devices are slow, because only little changes are introduced with a new design and test step.

Nowadays, and also in the foreseeable future, it will always be necessary to have a final full scale laboratory test, but it is only the final acceptance test, the end of a new design process. It is necessary to make a preliminary selection, to choose the devices to test in full scale. These preliminary analyses can be done in various ways, with more or less accurate procedures, but it is possible to use numerical methods and the applications of computational mechanics.

Computational mechanics is based on the use of complex finite element codes, that allows the virtual reproduction of real world problems. Regarding roadside safety, the design phase was, until now, based on the use of simplified analysis, unable to describe accurately the complexity of vehicle impacts against safety hardware.

To build a FE model for an impact problem many elements are necessary:

- Model geometry.
- Constitutive laws of the materials.
- Links (rigid, cinematic, etc.) between bodies or part of them.
- Definition and characterization of contact surfaces.

This set of information is needed for each different body involved in the event; making the development of a complete model very much demanding.

These data allow to build a system to study a generic complex physical phenomenon (e.g.: impact) tracking the evolution of dynamic and structural parameters in the space and time domain, in all the defined points of the geometry and in all the time steps of the simulation process.

The event to study can be defined also by other means, like the motion laws, particular restraints, action of force fields, etc.. This permits also to modify the simulation conditions and to obtain important possibilities of comparison, varying one or more variable parameter involved in the test.

Still, to be able to obtain a good reproduction with these experimental tools it is necessary that every component of the model and the whole model are validated by means of the comparison with real experimental data.

Because the system is composed by single bodies and each body is composed by several parts, once a part (subset) of the entire model has been accurately validated, it can be used again and again in other analogous models.

The limit that remains to the computational mechanics applications, apart from the validation and calibration (that sometimes require specific laboratory tests or additional measurements on full scale tests), are the resources and the time to perform the calculation of the simulation itself. The great development of computer hardware and software in the last years helped to solve many problems, but also showed new needs and new frontiers for the analysis.

DEVELOPMENT OF A NEW FE MODEL OF HGV

We present the development process of a new model, useful for the computational mechanics applications in roadside safety design. Our goal was to build and validate a FE model of an Heavy Goods Vehicle (HGV), starting from the previous simplified models, performed by our research team.

The model was built for and is ready to use with LS Dyna FE code, from Livermore Software Technology Corporation (LSTC). This software is widely used for road safety analyses, because it was recommended by the U.S. Federal Highway Administration (FHWA) for research on roadside safety.

It is characterized by:

- use of Lagrangian, Eulerian or mixed Lagrangian-Eulerian formulation;
- spatial discretization with isoparametric elements;
- explicit integration in time domain;
- database of more than 200 material models;
- possibility to include joints to reproduce machinery;
- contact surfaces;
- one, two, three dimensional and discrete elements.

There are some LS-DYNA roadside hardware and vehicle models ready for use available in a database sponsored by FHWA and National Highway Traffic Safety Administration (NHTSA), on the National Crash Analysis Center (NCAC) website. The FE code has a huge database of more than 200 material models

The reproduced vehicle

The European road restraint system acceptance standard (EN1317) classifies safety barriers on the basis of the lateral kinetic energy of the heavy vehicle full scale crash test; EN1317 requires that every safety barrier must be evaluated with two full scale crash test (light and heavy vehicle), performed in a laboratory, with certain procedures and with a particular vehicle. The maximum level is named Very high containment (H4) and it is divided in two sub classes: H4a (test with single unit truck, mass 30,000 kg) and H4b (test with articulated truck, mass 38,000 kg).

The division of this class in two subclasses is because the heaviest vehicle are the articulated vehicles, but in many cases the impact with the lower mass single unit truck, that is more rigid, proved to be the most severe for the barrier.

It is also to consider that in many states (like in Italy) the single unit trucks are more common than articulated vehicles.

For all these reasons there are many installations of H4a safety barriers, so there is a real need for design and testing tools in that class.

The truck for the H4a test has to be a 30,000 kg mass vehicle, single unit (rigid), with 4 axles and some other geometric requirements, like total dimensions, position of Center of Gravity etc.

As mentioned, there is a vehicle database for the safety devices research, but there is currently no available vehicle in this class. Since there are no other sources the only solution was to build a new vehicle model.

The vehicle reproduced as a Finite Element model was a FIAT IVECO F180NC, that was very common in Italy in the past and was used many times in the H4a (very high containment level) acceptance test. The availability of a good number of test reports and the possibility to measure the real vehicle helped the decision to choose this particular model. It is a single unit heavy truck, homologated for a maximum total weight of 32 ton, with an open bin.

This kind of vehicle is also interesting for the dynamic interaction with the road: due to the particular axles configuration and the total weight per axle it can be used for other phenomena, like the decay of road pavement structures and other road element.

Description of the vehicle

The vehicle used for all the measurements (see Figure 1) was built in 1984, but it was considered good because this vehicle was still popular in the 90's and the newer models have the same behavior when impacting a safety barrier: the impact of these large truck is characterized by their mass and main geometry, more than other details.

The vehicle has a net weight of 10.5 ton. The vehicle has 4 axles, the first two are steering axles and the third axle has twin wheels. In the current revision of the model the steering mechanism is not reproduced. This feature will be eventually be included in a further version. The lack of a functional steering mechanism can cause the simulation to miss something of the post-impact cinematic with some barriers, but in many real tests with roadside barriers the front wheel is detached, thus eliminating the need for a steering mechanism.

The vehicle chassis is essentially based on two large longitudinal and several minor transversal beams, plus the front driver's cabin, with the massive and rigid engine below.

The suspension system is based on leaf springs.

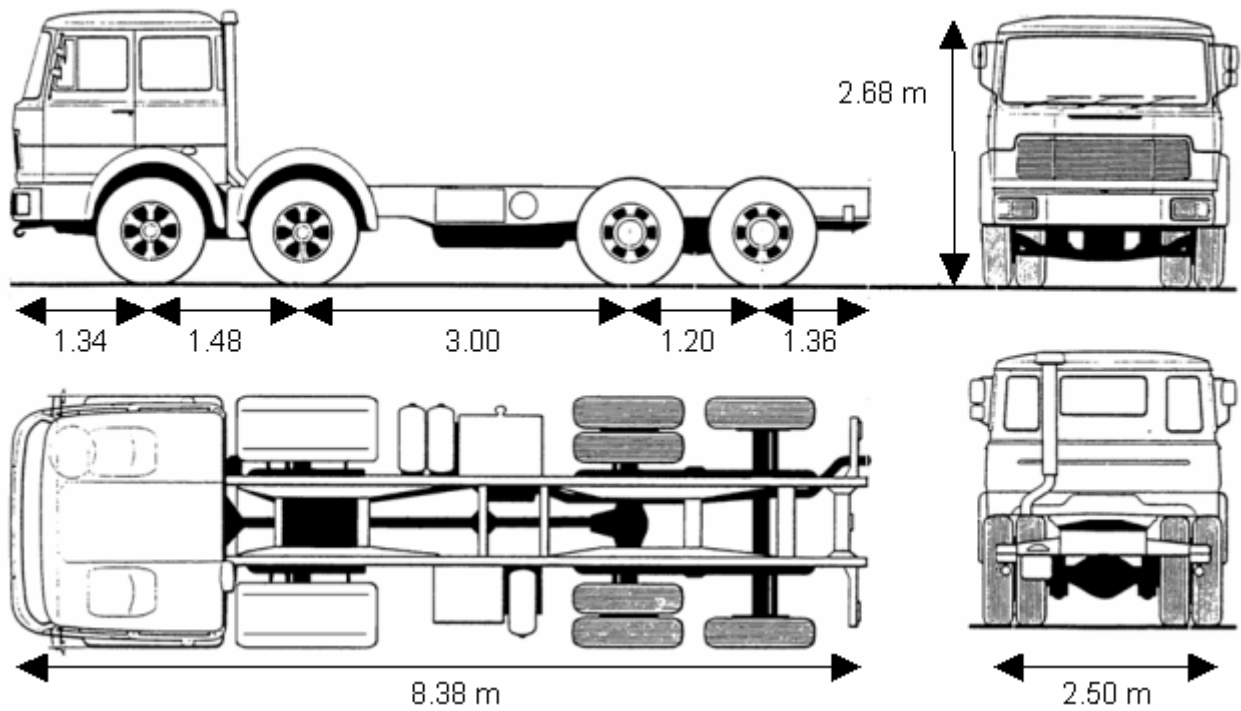

Figure 11. Dimensions of the original vehicle (FIAT IVECO F180NC).

Description of the model

The model (12337 elements and 11470 nodes) was built to use with LS DYNA FE code from Livermore Software Technology Corporation.

The main dimensions of the HGV model are shown in Figure 2.

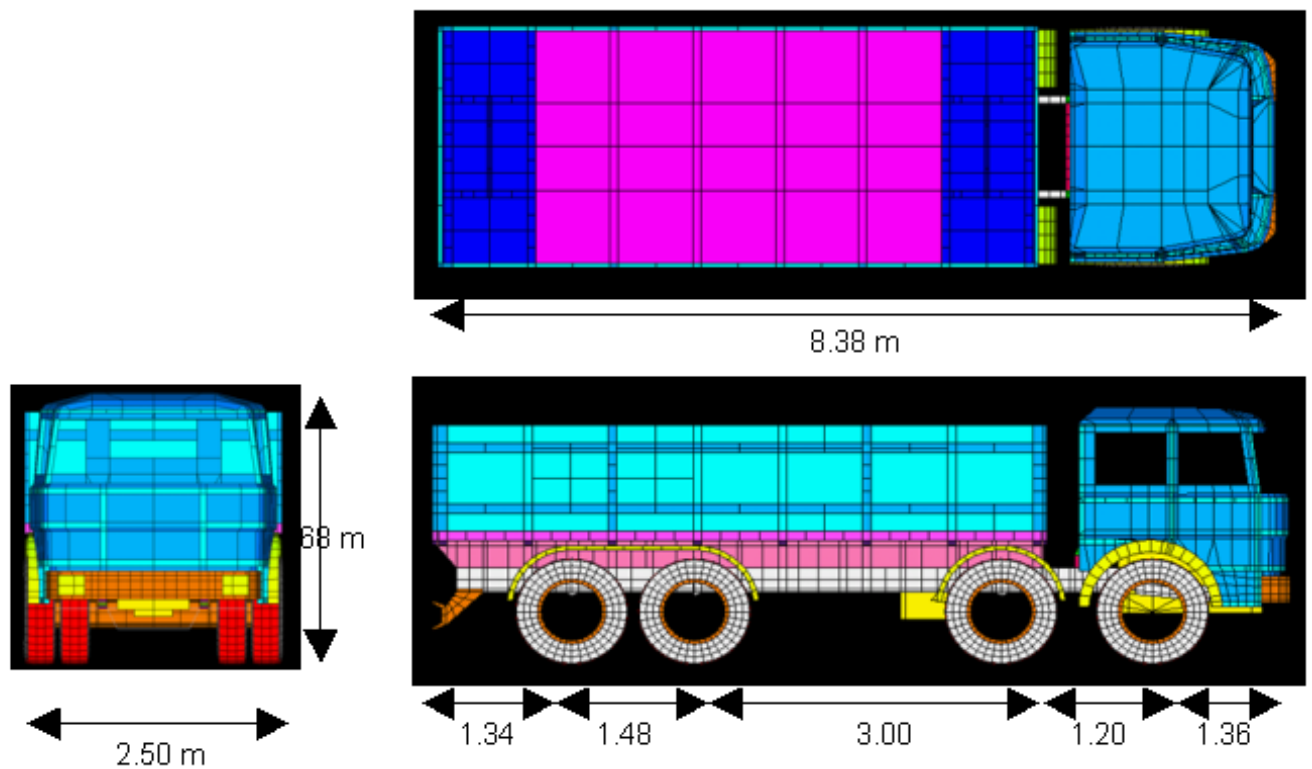

Figure 2. Finite element model of the heavy vehicle.

The model is divided into parts, necessary when the type of finite element or material is different and useful to divide logically two regions in some cases.

The main part of the chassis is built with 4 or (when needed by geometry) 3 nodes shell element, Belytschko-Tsay formulation and thickness according to the measured values. Some parts (like the engine and the load) are modeled with 8 nodes solid element, single integration point, and rigid material: these parts are not supposed to deform significantly and this is a good way to reduce calculation times.

In the next figures (3, 4 and 5) the vehicle model is represented, showing the loaded and unloaded vehicle, the vehicle layout and structure.

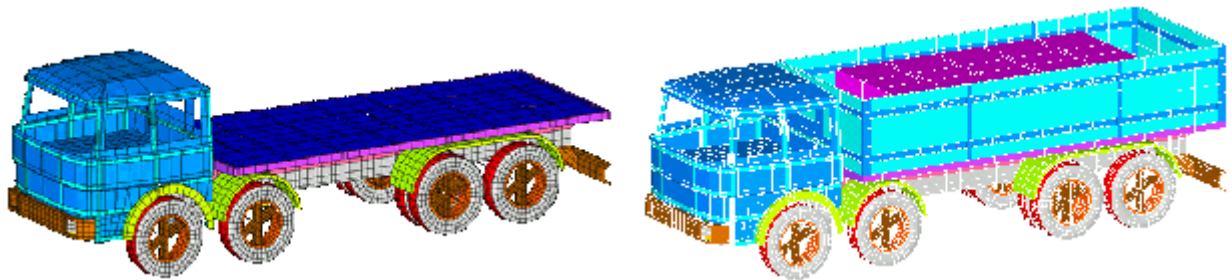

Figure 3. FE model of the heavy vehicle unloaded (10,560 kg) and loaded (30,000 kg).

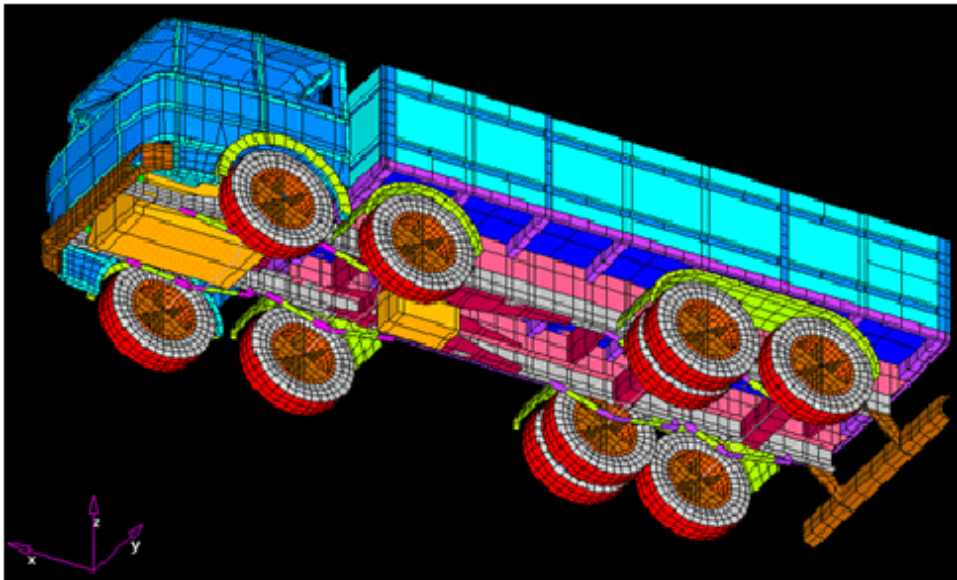

Figure 4. Bottom view of the FE model.

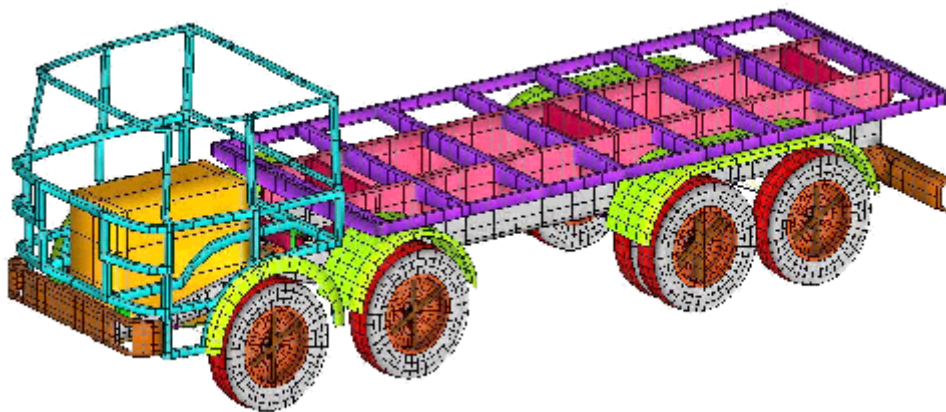

Figure 5. Chassis of the FE model.

The axles are modeled with beam elements, Belytschko-Schwer tubular beam with cross-section integration formulation.

There are some discrete elements, to reproduce correctly the suspension system, that act like a discrete simple linear damper or spring (see Figure 6).

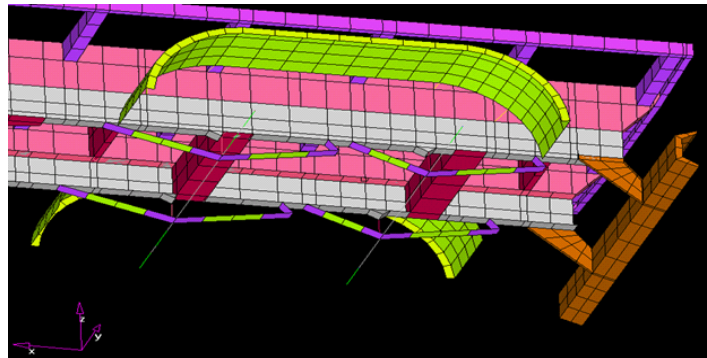

Figure 6. Detail of the rear axles and suspension system.

The wheels are connected to the axles via a revolution joint, to reproduce correctly their rotation.

Model validation

After the model completion, it was validated, (see Figure 7 and 8) with the comparison between real crash tests where the actual F180NC was used as a test vehicle and the virtual test.

One of these, that gave to the model the final validation, was done in the year 2000 in a European laboratory and was the acceptance test of a steel bridge barrier (class H4a).

The test conditions were:

- vehicle impact speed 66.5 km/h
- impact angle 20°
- tested vehicle mass 30,250 kg

It was necessary, in this case, to accurately model the barrier, the road surface, the connection to the bridge beam and all the important details, like the material models.

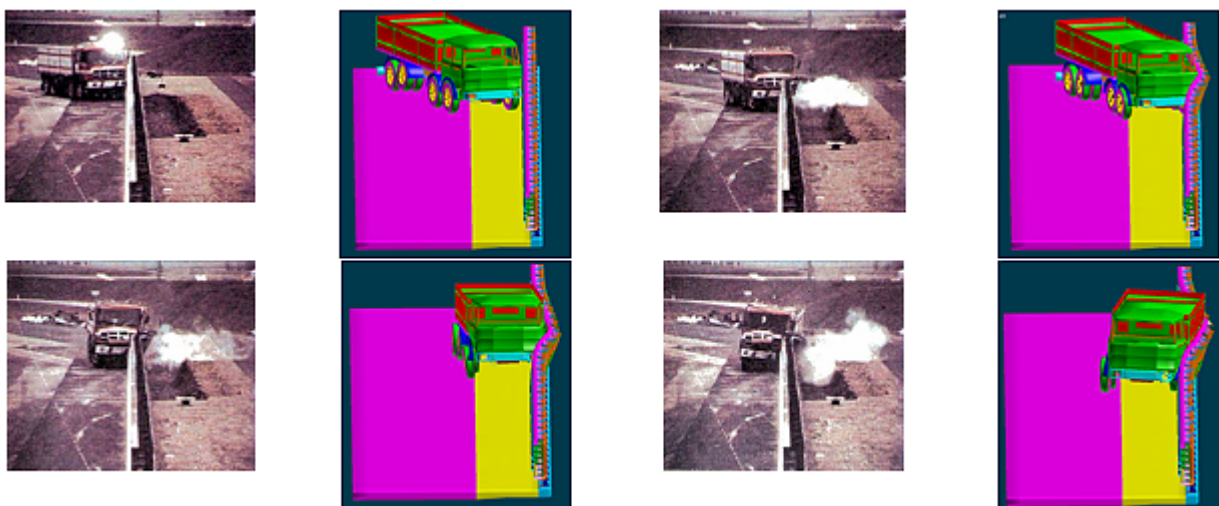

Figure 7. Validation of the heavy vehicle with a steel bridge barrier.

The model has been considered validated when, after several virtual test and model refinements, the following results were achieved:

- correct reproduction of the kinematics and dynamics of the test, in particular post impact velocity and trajectory, length of the barrier deformed by the impact);
- good correlation between residual deformation of the vehicle and barrier, real and virtual.

Regarding the second point, some differences between the real and virtual barrier deformation (the virtual test gave lower deformations) were attributed partly to the model accuracy, but mainly to the load disconnection in the real test. The vehicle deformation, considered globally, has a good accordance with the real event.



Figure 8. Validation of the heavy vehicle model with a reinforced concrete barrier.

APPLICATIONS AND FUTURE DEVELOPMENTS

After the model validation, it was used widely in our researches. These researches are about passive safety of restraint system, the dynamic effect of vehicle – road interaction (pavement, structures and surrounding elements).

Many of these researches were presented in meetings and seminars, so this paper gives only a short resume of these experiences, to testify the versatility and the capabilities of this model.

Simulation of impact on bridge barriers

Many cases were analyzed, with the barrier mounted at different levels over the road surface.

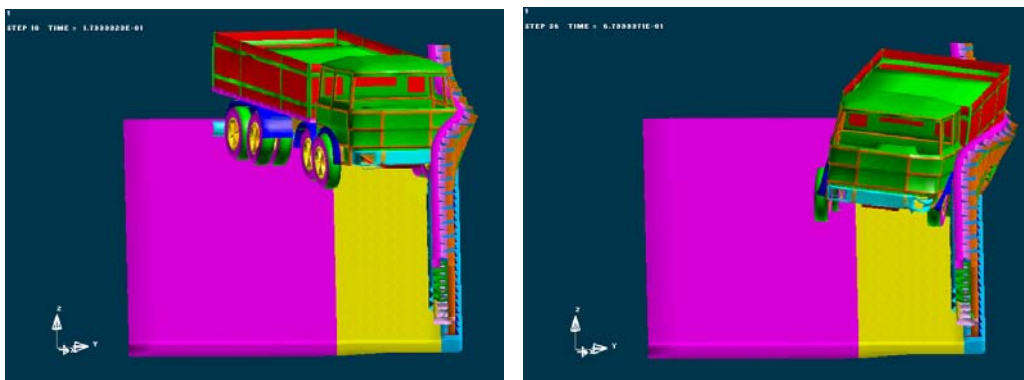

Figure 9. Shots from the simulation of HGV to steel bridge barrier impact.

The model was used to evaluate the actions (shear forces and bending moments) transferred by the barrier to the bridge deck when impacted by the heavy vehicle (see Bonin G., Ranzo A., 2004).

Simulation of impact with rigid barriers (reinforced concrete) with short element length

The research started from an existing RC barrier with New Jersey profile, trying to reduce the severity on light vehicles by using smaller elements (length 2 m versus the original 6 m design).



Figure 10. Shots from the simulation of HGV to reinforced concrete barrier impact.

This research pointed out that the short element RC barrier is able to contain and redirect adequately the heavy vehicle; the new design moreover has a better behaviour respect to the reduction of the occupant risk when the barrier is impacted by a light vehicle (see Bonin G., Cantisani G., Loprencipe G., 2004).

Simulation of impact with earth reinforced barriers

The research aimed to define a new barrier technology with the use of a natural granular material, contained by geo textiles layers and steel grids. This new kind of barrier is currently under development, because showed good containment capabilities, but high impact severity with the light vehicles. It can be useful where it is easy to find granular material and for the possibility to cover the whole barrier with a grass layer (see Bonin G., Cantisani G., Loprencipe G., 2004).

Effects of the dynamic interaction with the road unevenness

Starting from the preliminary FE models of road pavements (concrete and asphalt pavement), necessary for this study, we used our vehicle model to evaluate the dynamic actions on the pavement in presence of a local road unevenness. The layers of pavement has been modeled with different elastic characteristics. Since the dynamic actions are developed in very brief time and usually the stresses does not exceed the elastic limit, in the preliminary model FE we used the elastic constitutive law, also for the flexible pavements. To reproduce the real cases in urban situations, various pavement structures have been chosen for the analysis (see Bonin G., Cantisani G., Loprencipe G., 2004).

Effects of the dynamic interaction with bridge expansion joints

The problem of the dynamic interactions between Bridge Expansion Joints (BEJ) and the HGV has been studied with a 3D FE model. The model allows to determine, varying the parameters of the test vehicle (load, dimensions and speed), joint unevenness dimensions (amplitude and wavelength) and pavement modulus, the stresses and deformations on joint and each pavement layer due to dynamic actions generated by vehicle motion. The model allows also to determine the accelerations on the vehicle, to verify the Ride Quality of the given uneven pavement, with geometric dimensions A, B, C, D, H (see Figure 11 and Bonin G., Loprencipe G., Ranzo A., 2002).

Actually there are other experimentations under development, to enhance the proposed research and to find new applications. In particular the vehicle model is being upgraded with a complete steering mechanism on the two front axles, useful in some impact simulations.

The heavy truck has been also used by other international research teams, to analyze vehicle to barrier and vehicle to vehicle impacts (see Atahan Ali O. et al., 2003).

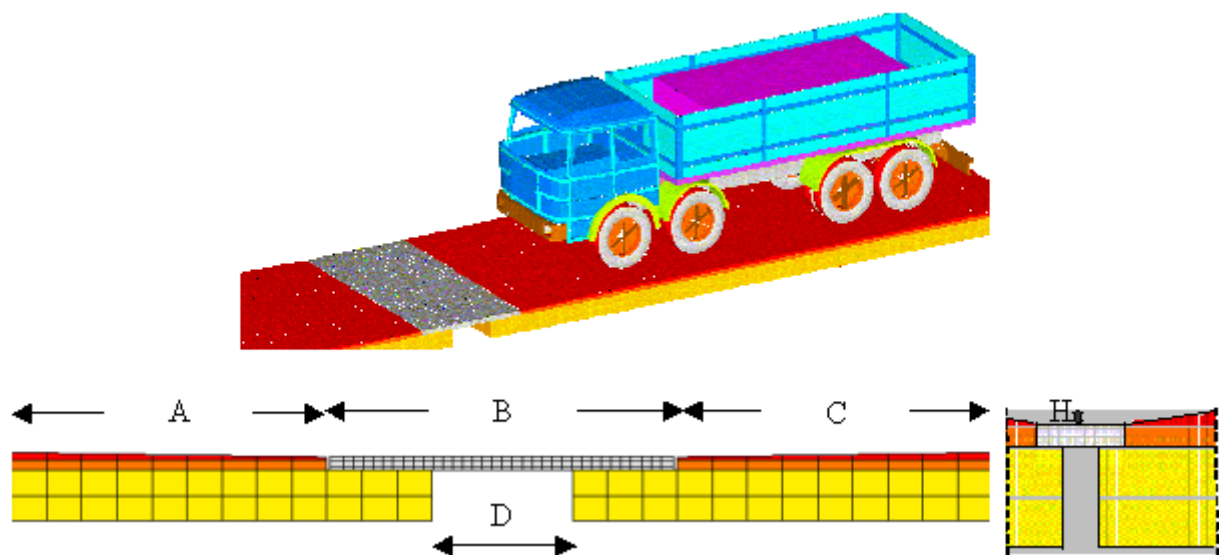

Figure 11. Computational mechanics model (up). Pavement and BEJ model (detail of BEJ zone) (down).

CONCLUSIONS

The characteristics of the HGV FE model, developed and validated using LS-DYNA FE code have been presented in this paper. The model is versatile, was used for many applications and showed good potential for research involving road passive safety and road structure analysis.

The vehicle is suitable for the simulation of EN1317 safety barrier acceptance test, H4a containment level (TB71 test); this test level is very important because is probably the most demanding for a safety barrier and these kind of vehicle are representative of the most common heavy vehicle.

The great interest about this model is confirmed by the requests of other international research teams, that received the model and used it for their studies.

The vehicle model is continuously upgraded with the evidence from the various virtual tests performed and refined on the basis of new laboratory full scale data. The next major upgrades will be the introduction of the steering mechanism in the two front axles and the improvement of suspension system model.

REFERENCES

1. Atahan Ali O., Abhishek S Joshi, Moustafa El-Gindy, A Rear-End Protection Device For Heavy Vehicles, Proceedings of IMECE'03 ASME International Mechanical Engineering Congress and Exposition, 2003, Washington D.C.
2. Bonin G., Cantisani G., Loprencipe G., Computational 3D model of vehicle's crash on passive safety systems, Proceedings of 8th International Symposium on Heavy Vehicle Weights and Dimensions, South Africa March 14-18 2004.
3. Bonin G., Loprencipe G., Ranzo A., Traffic dynamic effects on bridge joint, Proceedings of the IABMAS 2002 – First International Conference on Bridge Maintenance, Safety and Management, Barcelona, 2002.
4. Bonin G., Ranzo A., Dynamic actions on bridge slabs due to heavy vehicle impact on roadside barriers, Proceedings of the 83rd Transportation Research Board annual meeting, Washington D.C. January 11-15 2004.
5. EN 1317-1 - Road restraint systems – Part 1: terminology and general criteria for test methods, April 1998.
6. EN 1317-2 - Road restraint systems – Part 2: performance classes, impact test acceptance criteria and test methods for safety barriers, April 1998.
7. Hallquist J. O., Ls-Dyna Theoretical manual. Livermore Software Technology Corporation, 1998.

8. NCHRP REPORT 350, Recommended procedures for the safety performance evaluation of highway features, TRC-NRC, 1993, (USA).
9. Ray M.H., Repeatability of full scale tests and criteria for validating simulations results, TRB, 1996.
10. Zienkiewicz O.C, Taylor R.L., The finite element method - 5th ed., Butterworth Heinemann, 2000.