



Contents lists available at ScienceDirect

## Nuclear Inst. and Methods in Physics Research, A

journal homepage: [www.elsevier.com/locate/nima](http://www.elsevier.com/locate/nima)

## MariX, an advanced MHz-class repetition rate X-ray source for linear regime time-resolved spectroscopy and photon scattering

L. Serafini<sup>1</sup>, A. Bacci<sup>1</sup>, A. Bellandi<sup>2</sup>, M. Bertucci<sup>1</sup>, M. Bolognesi<sup>3</sup>, A. Bosotti<sup>1</sup>, F. Broggi<sup>1</sup>, R. Calandrino<sup>4</sup>, F. Camera<sup>3,1</sup>, F. Canella<sup>3</sup>, S. Capra<sup>3,1</sup>, P. Cardarelli<sup>5,6</sup>, M. Carrara<sup>7</sup>, K. Cassou<sup>8</sup>, A. Castoldi<sup>9,1</sup>, R. Castriconi<sup>4</sup>, G.M. Cattaneo<sup>4</sup>, S. Cialdi<sup>3,1</sup>, A. Cianchi<sup>10</sup>, N. Coluccelli<sup>9,11</sup>, C. Curatolo<sup>12</sup>, A. Del Vecchio<sup>4</sup>, S. Di Mitri<sup>13</sup>, I. Drebot<sup>1</sup>, K. Dupraz<sup>8</sup>, A. Esposito<sup>14</sup>, L. Faillace<sup>1</sup>, M. Ferrario<sup>14</sup>, C. Fiorini<sup>9,1</sup>, G. Galzerano<sup>11,9</sup>, M. Gambaccini<sup>5,6</sup>, G. Ghiringhelli<sup>9</sup>, D. Giannotti<sup>1</sup>, D. Giove<sup>1</sup>, F. Groppi<sup>3,1</sup>, C. Guazzoni<sup>9,1</sup>, P. Laporta<sup>9,11</sup>, S. Leoni<sup>3,1</sup>, A. Loria<sup>4</sup>, P. Mangili<sup>4</sup>, A. Martens<sup>8</sup>, T. Mazza<sup>15</sup>, Z. Mazzotta<sup>16</sup>, C. Meroni<sup>1</sup>, G. Mettievier<sup>17</sup>, P. Michelato<sup>1</sup>, L. Monaco<sup>1</sup>, S. Morante<sup>10</sup>, M. Moretti Sala<sup>9</sup>, D. Nutarelli<sup>8</sup>, S. Olivares<sup>3,1</sup>, G. Onida<sup>3</sup>, M. Opromolla<sup>3,1</sup>, C. Pagani<sup>3,1</sup>, R. Paparella<sup>1</sup>, M.G.A. Paris<sup>3,1</sup>, B. Paroli<sup>3,1</sup>, G. Paternò<sup>6</sup>, C. Paulin<sup>3</sup>, L. Perini<sup>3,1</sup>, M. Petrarca<sup>18</sup>, V. Petrillo<sup>3,1,\*</sup>, E. Pinotti<sup>9</sup>, P. Piseri<sup>3,1</sup>, M.A.C. Potenza<sup>3</sup>, F. Prezl<sup>1</sup>, A. Pullia<sup>3,1</sup>, E. Puppini<sup>9,1</sup>, F. Ragusa<sup>3,1</sup>, R. Ramponi<sup>9,11,1</sup>, M. Romè<sup>3,1</sup>, M. Rossetti Conti<sup>1</sup>, A.R. Rossi<sup>1</sup>, L. Rossi<sup>19</sup>, M. Ruijter<sup>18,1</sup>, P. Russo<sup>17</sup>, S. Samsam<sup>20,1</sup>, A. Sarno<sup>17</sup>, D. Sertore<sup>1</sup>, M. Sorbi<sup>3,1</sup>, B. Spataro<sup>14</sup>, M. Statera<sup>1</sup>, F. Stellato<sup>10</sup>, E. Suerra<sup>3,1</sup>, A. Tagliaferri<sup>9</sup>, A. Taibi<sup>5,6</sup>, V. Torri<sup>1</sup>, G. Turchetti<sup>21</sup>, C. Vaccarezza<sup>14</sup>, R. Valdagni<sup>22</sup>, A. Vanzulli<sup>3,23</sup>, F. Zomer<sup>8</sup>, G. Rossi<sup>3</sup>

<sup>1</sup> INFN - Sezione di Milano, Via Celoria 16, 20133, Milano and LASA, Via F. Cervi 201, 20090 Segrate (MI), Italy

<sup>2</sup> DESY, Notkestrasse 85, 22603 Hamburg, Germany

<sup>3</sup> Università degli Studi di Milano, Via Festa del Perdono 7, 20100 Milano, Italy

<sup>4</sup> Istituto di Ricovero e Cura a Carattere Scientifico Ospedale San Raffaele, Via Olgettina 60, 20132 Milano, Italy

<sup>5</sup> Università di Ferrara, Via Saragat, 1 44122 Ferrara, Italy

<sup>6</sup> INFN - Sezione di Ferrara, Via Saragat, 1 44122 Ferrara, Italy

<sup>7</sup> Istituto Nazionale dei Tumori, Via Giacomo Venezian, 1 - 20133 Milano, Italy

<sup>8</sup> LAL, Univ. Paris-Sud, CNRS/IN2P3, Université Paris-Saclay, 91898 Orsay, France

<sup>9</sup> Politecnico di Milano, Piazza Leonardo da Vinci, 32 20133 Milano, Italy

<sup>10</sup> Università degli Studi di Roma Tor Vergata and INFN, Via della Ricerca Scientifica, 1 00133 Roma, Italy

<sup>11</sup> Istituto di Fotonica e Nanotecnologie, CNR, Piazza Leonardo da Vinci, 32 20133 Milano, Italy

<sup>12</sup> INFN - Sezione di Padova, Via Marzolo, 8 - 35131 Padova, Italy

<sup>13</sup> Elettra - Sincrotrone Trieste, 34149 Basovizza, Trieste, Italy

<sup>14</sup> INFN - Laboratori Nazionali di Frascati, Via Enrico Fermi, 40 00044 Frascati (RM), Italy

<sup>15</sup> European X-ray Free Electron Laser Facility GmbH, Holzkoppel, 4 - 22869 Schenefeld, Germany

<sup>16</sup> ARCNL, Advanced Research Center for Nano-Lithography, EUV Group, 106 Science Park, 1098xg Amsterdam, The Netherlands

<sup>17</sup> Università degli Studi di Napoli 'Federico II', Dipartimento di Fisica 'E. Pancini' and INFN Sez. Napoli, Via Cintia, 80126, Napoli, Italy

<sup>18</sup> Università degli Studi di Roma 'La Sapienza' and INFN, Piazzale Aldo Moro, 5 - 00185 Roma, Italy

<sup>19</sup> CERN - Accelerator & Technology Sector, Esplanade des Particules, 1 - 1217 Meyrin, Switzerland. On leave from Università Degli Studi di Milano.

<sup>20</sup> Faculty of Sciences, Mohammed V University, Rabat, Morocco

<sup>21</sup> Alma Mater Studiorum - Università di Bologna, Dipartimento di Fisica e Astronomia, via Irnerio, 46 40126 Bologna, Italy

<sup>22</sup> Istituto Nazionale dei Tumori, Via Giacomo Venezian, 1 - 20133, Milano, Italy and Università degli Studi di Milano, Dipartimento di Oncologia ed Emato-oncologia, Via S. Sofia, 9/1 - 20122 Milano, Italy

<sup>23</sup> ASST Grande Ospedale Metropolitano Niguarda, Piazza Ospedale Maggiore, 3 - 20162 Milano, Italy

\* Corresponding author at: Università degli Studi di Milano, Via Festa del Perdono 7, 20100 Milano, Italy.  
E-mail address: [Petrillo@mi.infn.it](mailto:Petrillo@mi.infn.it) (V. Petrillo).

<https://doi.org/10.1016/j.nima.2019.03.096>

Received 11 February 2019; Received in revised form 25 March 2019; Accepted 31 March 2019

Available online 3 April 2019

0168-9002/© 2019 Elsevier B.V. All rights reserved.

## ARTICLE INFO

## Keywords:

Linear accelerators  
Free-electron lasers

## ABSTRACT

The need of a fs-scale pulsed, high repetition rate, X-ray source for time-resolved fine analysis of matter (spectroscopy and photon scattering) in the linear response regime is addressed by the conceptual design of a facility called MariX (Multi-disciplinary Advanced Research Infrastructure for the generation and application of X-rays) outperforming current X-ray sources for the declared scope. MariX is based on the original design of a two-pass two-way superconducting linear electron accelerator, equipped with an arc compressor, to be operated in CW mode (1 MHz). MariX provides FEL emission in the range 0.2–8 keV with  $10^8$  photons per pulse ideally suited for photoelectric effect and inelastic X-ray scattering experiments. The accelerator complex includes an early stage that supports an advanced inverse Compton source of very high-flux hard X-rays of energies up to 180 keV that is well adapted for large area radiological imaging, realizing a broad science programme and serving a multidisciplinary user community, covering fundamental science of matter and application to life sciences, including health at preclinical and clinical level.

## 1. Introduction

Analytical Research Infrastructures (ARIs) based on electron accelerators are at the basis of Photon Science that describes the multi-disciplinary implementation of fine analysis of matter, extending from the life sciences to materials science and physics. Currently two main types of X-ray sources are supporting the ARIs: synchrotron radiation sources based on low-emittance electron storage rings and Free Electron Lasers (FELs) based on linear electron accelerators (Linacs) and self-amplification of spontaneous emission (SASE). Pioneering FEL sources have been operated at Stanford University (LCLS) since 2009 [1] and at Spring-8 (SACLA) since 2011 [2], three X-ray FELs have recently started operation in Europe (EU-XFEL [3] and SwissFEL [4]) and in Korea (Pohang [5]) and novel constructions are underway worldwide: Shanghai [6], LCLS-II [7], MaRIE [8]. All these sources provide ultra-bright pulses of 10–100 fs duration with the intrinsic time jitter and intensity fluctuation from pulse to pulse determined by the SASE process. Two FEL emitting in the VUV-Soft-X rays are also operational in Europe, FLASH in Hamburg [9] and FERMI in Trieste [10]. FERMI is the only existing seeded FEL, i.e. the only FEL-type amplifier of a Ti:Sa seed pulse with negligible time jitter and minor pulse to pulse intensity fluctuations: it operates at up to 50 Hz. The FEL sources provide extremely brilliant pulses, exceeding by more than 9 orders of magnitude the peak brilliance of the fourth generation storage rings, and reaching more than  $10^{12}$  photons per pulse of <100 fs duration. These flashes of UV and X-ray radiation can be used in experiments to probe matter in a highly excited state, dominated by non-linear response, or to probe before destroying individual objects, like macromolecules (proteins) ideally replacing crystallography with single object imaging. Pump and probe experiments are made possible by sequentially exciting with tunable optical or IR lasers and subsequently probing with the FEL pulse at finely tuned 10–100 fs-scale delays, or inverting the experiments by pumping with FEL X-rays and probing with ultra-short optical pulses from lasers or High Harmonic Generation (HHG) sources in the VUV. Up to now, much of the success of FEL-based experiments has been in the study of the internal structure or ordering of materials (solids, molecules, atoms). This is due to the inherent efficiency of those experiments, which are often compatible with single pulse detection. On the contrary spectroscopic probes, suitable to study magnetic and electronic structures, are more demanding in terms of average photon flux on the sample, and are thus harder to implement at low repetition rates.

Time resolution of 10–100 fs has emerged as a need of fine analysis also in spectroscopy, that, on the other hand, requires photon excitation density to remain instantaneously within the limit of linear response. The observation of the competition between transient configurations of excited matter (e.g. photo-excited by tunable fs laser pulses) can serve the understanding of the ground state of complex matter, like materials whose properties are driven by high electron correlation

that is reflected in a spectrum of quasi-particle excitations, that determines the order parameters in matter like magnetism, ferroelectricity, superconductivity orbital order and more.

This study of transient and metastable states of matter can be ideally performed with ultra-short soft and hard X-ray pulses used to probe the electronic and magnetic structure after an initial pump has perturbed the ground state.

Currently this time domain is covered by fs laser optical spectroscopy as well as by photoelectric effect spectroscopy as excited by 10–100 fs laser driven HHG sources reaching energies of the order of 0.1 keV and repetition rates of several 100 kHz in the best cases. Further development of laser based sources is expected, but adequate intensities (number of photons per pulse) and repetition rates (number of pulses per second) can be realized today only by electron-accelerator based FELs.

Pump probe photoemission experiments of high scientific impact in atomic, molecular, nanoparticle and solid state physics ideally require a source of ultra-short photon pulses (order 10 fs) with about  $10^8$  photons/pulse to remain, according to photoionization cross sections, in the linear or near-linear response regime that allows spectroscopy to be interpreted within perturbative approaches, and repetition rates as high as possible (MHz range) for collecting adequate statistics in short times. MHz repetition rates are adequate to pump-probe experiments as ultra-short IR or tunable HHG pump sources can be employed to prepare the excited state and microsecond intervals between subsequent experiments are generally sufficient to reproduce the initial ground state of the sample.

Currently available FEL sources are far from being ideal for spectroscopy as the number of photons per pulse exceeds by 2–4 orders of magnitude that compatible with the linear response regime: severe attenuation of the pulses is, therefore, required for e.g. photoemission or X-ray absorption spectroscopy (XAS) and X-ray Magnetic circular dichroism (XMCD) experiments and this wastes an astounding fraction of the operating energy of the FEL. The warm Linacs are limited to few tens of Hz repetition rate, up to 100/120 Hz, which is definitely non ideal for collecting adequate statistics in high resolution spectroscopy. The EU-XFEL generates 2700 micropulses at 4.5 MHz in 10 macropulses per second: this is also non ideal as both attenuation is needed and the repetition rate of the micropulses is so high that it overruns the present capabilities of detectors and of possible pump-probe set-up operation. SASE fluctuations pose severe limitations to the use of FELs in X-ray spectroscopy. True seeding, as successfully done by FERMI, should be ideally extended to X-ray energies.

There is clearly the scientific need of a novel type of source that would provide 10 fs pulses of  $10^8$  photons at 1–2 MHz, bridging the gap between the most advanced SR and the current FEL sources. The former are aiming, in the future years, at few-ps pulses at up to 500 MHz (current pulses are in the few tens of ps range) i.e.  $(5 \times 10^8)$  pulses/s with typically  $10^5$ – $10^6$  photons/pulse; the latter are yielding 10–100 fs pulses at  $10^1$ – $10^4$  pulses/s with  $10^{12}$  photons/pulse. This evident gap in

**Table 1**  
Electron beam and laser of BriXS.

Electron beam energy	MeV	100	Laser pulse energy	mJ	7.5
Bunch charge	pC	200	Laser wavelength	nm	1030
Normalized emittance	mm mrad	1.2	Laser pulse length	ps	2
Relative energy spread	%	1.6	Laser spot size, x	$\mu\text{m}$	40
Bunch length	$\mu\text{m}$	400	Laser spot size, y	$\mu\text{m}$	80
Focal spot size	$\mu\text{m}$	20	Collision angle	deg	7

timing resolution and average photon flux can be filled by the source proposed here, that has been conceived for this very scope.

HHG sources have been developed in laboratories as well as in pioneering user facilities, with 100 fs range pulses of  $10^7$  photons/pulse at some  $10^5$  pulses/s, but are currently limited at energies below 100 eV. Shorter, sub-fs pulses are generated by HHG, but at kHz repetition rate at most. Higher photon energies have been demonstrated but currently with a low number of photons per pulse, which is unsuitable for fine analysis experiments.

Here we outline some elements of scientific case in advanced photon science, and the results issued from the conceptual design of an electron accelerator complex at the core of a novel facility called MariX (Multi-disciplinary Advanced Research Infrastructure for the generation and application of X-rays). The MariX source will provide tailored ultra-short pulses of optimal intensity and repetition rate delivered to a multi-instrument suite (beamlines) for research in many diverse science domains and applications.

The MariX accelerator complex includes a two-pass FEL with arc compressor for high brilliance X-ray pulses and an advanced inverse Compton source (ICS) of very high X-ray energy (up to 180 keV).

The desired pulse structure, intensity, repetition rate, reduced jitter and potential implementation of true seeding are addressed by this conceptual design study that has been carried out by a broad collaborative effort led by the Milan Section of INFN and Dipartimento di Fisica of Università di Milano, with contributions from Dipartimento di Fisica of Politecnico di Milano and other Universities and Research Institutes, in the framework of the design of a green-field new science campus in the outskirts of Milano. Besides tailoring the FEL and ICS sources for science, the environment of a science campus has also played a role in optimizing footprint and logistics obtaining an overall original configuration where all key operational buildings for the source services and experimental hall are located next to each other, thanks to the two-way operation of the superconducting Linac accelerator.

The design of the machine has been therefore conceptualized according to the following guidelines: (a) the overall footprint of the infrastructure has been minimized. (b) The performance of the source has been optimized in terms of versatility, operational easiness, quality of the radiation. (c) The resulting X-ray source is filling a science gap that is not addressed by the existing or planned photon sources. (d) The proposed technologies and techniques are within the limits of the state of the art or just beyond it, in order to balance risks and competitiveness.

Hereafter we first describe the machine layout. Then, we will discuss the nominal parameters. Final comments will be presented in the conclusions.

## 2. Machine layout

MariX is a multi-purpose infrastructure constituted by two different X-ray sources exploiting different sections of the accelerator chain – an Inverse Compton Scattering source and a Free-Electron Laser – with properties that contribute to define the next generation X-ray sources tailored to spectroscopy and imaging. Ultrabright, coherent ultrashort photon pulses of energy between 200 eV and 8 keV will be produced by the FEL at 1–2 MHz, and intense X-ray beams of energy up to 180 keV will be generated by the ICS section at up to 100 MHz. The compactness of the design of accelerator and undulators (less than 500

m long) greatly reduces the footprint of the complex for the benefit of its integration in highly urbanized areas or university campuses. On the contrary the X-ray FEL accelerators in operation (e.g. EuXFEL [3]) or under construction (e.g. LCLS-II [7]) are few km long, with key services and experimental halls at the opposite ends. Ultrahigh flux and compact construction in our design are consequent to the use of Super-Conducting Linear Accelerators (SC-Linacs) supporting the Continuous-Wave mode (CW) for delivering high brightness FEL-grade electron beams. By exploiting the specific capability of the SC Radiofrequency cavities of accelerating in both directions, the electron beam can double its energy after being re-injected into the accelerator itself. The innovative MariX layout is illustrated in Fig. 1.

The MariX early electron beam acceleration section includes an energy recovery scheme based on a modified folded push-pull CW-SC twin Linac ensemble (ERL1 and ERL2). The system allows sustaining MW-class beam power with just about one hundred kW active power dissipation/consumption and is exploited for a Bright and Compact X-ray Source (BriXS). The two CW 100 MHz 100 MeV electron beams are delivered at the ICS collision points, for scattering the photons of optical laser pulses in two specular Fabry-Pérot cavities (marked as FP1 and FP2 in the bottom part of Fig. 1). While feeding hard X-ray beamlines for imaging purposes, BriXS constitutes the injector for the downstream FEL.

The second block of the MariX accelerator complex is the two-pass two-way Linac (Linac1 in Fig. 1) equipped with an arc compressor (AC) [11,12] similar to a conventional Double Bending Achromat (DBA) magnetic lattice of a storage ring (e.g. Elettra-like [13]). The arc compressor is composed by 14 DBA sections, 10 with positive and 4 with negative curvature radius for a smooth matching to the Linac. The electron beam, leaving the Linac after being accelerated once, is re-injected after passing through the arc compressor so to get boosted twice in energy in the second pass. Referring to the position of the elements of the line in Fig. 1, the first pass is left-to-right and the second pass right-to-left. At the same time, the dispersive strength of the ring, combined with a suitable electron energy longitudinal chirp, permits the arc to act as compressor with compression factors of the order of 100, thus preparing an ultra-short and high-current electron beam suitable for FEL operation. Furthermore, the complete rotation of the longitudinal phase space during the compression The FEL electron beam, after a second short Linac (Linac2, at the left side of Fig. 1) devoted to fine energy tuning, reaches a maximum 3.8 GeV energy, thus allowing the FEL to radiate up to 8 keV actually operating only a 1.5 GeV Linac (that also includes the BriXS ERL delivering the initial 0.1 GeV injection energy). A high harmonic cavity and a dedicated transfer line are foreseen between Linac1 and the arc for energy chirping and optimizing the matching of the electron beam to the compressor. The variable gap undulators UliX1 (with period  $\lambda_w = 2.8$  cm and maximum undulator parameter  $a_w = 2.5$ , generating radiation from 200 eV to 4 keV) and UliX2 ( $\lambda_w = 1.2$  cm and maximum undulator parameter  $a_w = 0.65$ , delivering 2–8 keV) with their matching lines complete the device. The short period undulator has parameters not far from the state of the art. An important characteristics of the complex is that the FEL and ICS experimental halls are contiguous opening to a possible mutual interaction. Fig. 2 gives an artistic rendering of the buildings hosting the infrastructure (upper window: projected view, bottom window: perspective view).

## 3. Expected performance

The nominal beam parameters and the expected ICS radiation characteristics are summarized respectively in Table 1 and in Table 2.

These results have been obtained by start-to-end simulations performed with a chain of codes: Astra [15] and T-step [16] for the injector, Elegant [17] for the Linacs and passive lines, CAIN [18] for the ICS.

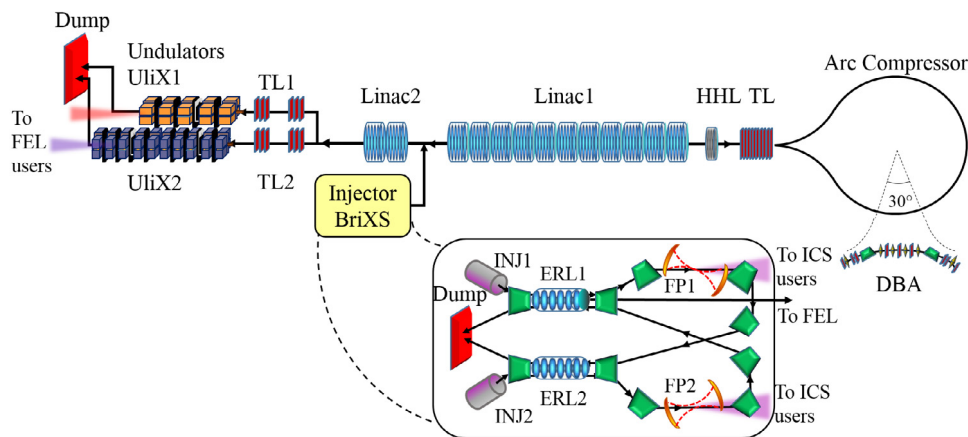

Fig. 1. Conceptual lay-out for MariX, based on a two-pass CW Super-Conducting CW GeV-class Linac driven by a folded push-pull Energy Recovery 100 MeV Linac.

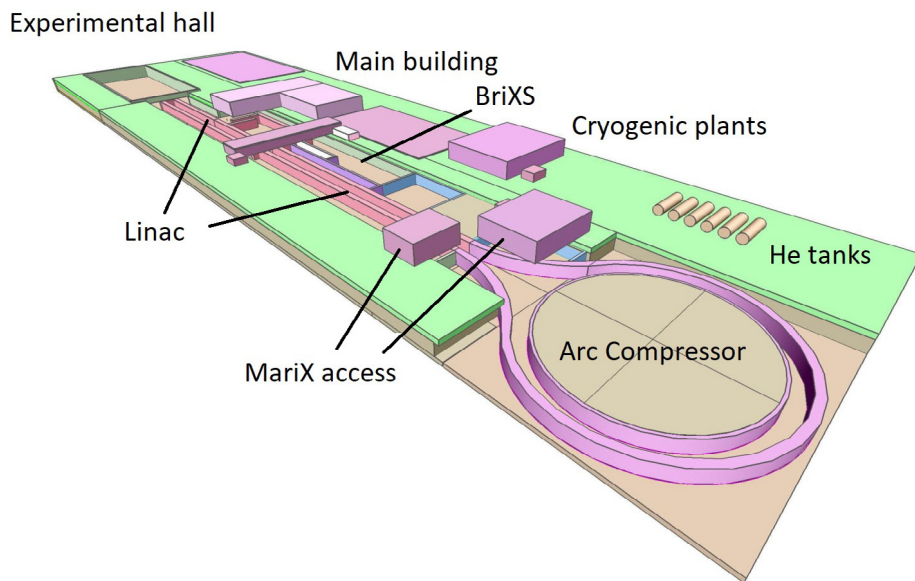
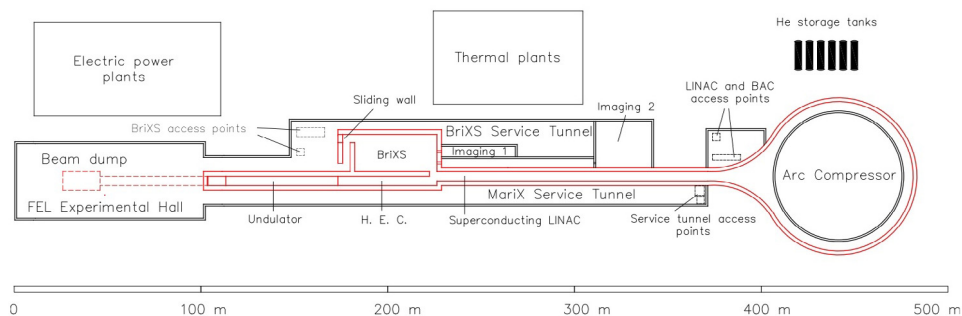

Fig. 2. Schematic representation of the buildings hosting the infrastructure. Upper window: projected view, bottom window: perspective view.

Table 2

BriXS radiation characteristics, \$ = Photons/s/mm<sup>2</sup>/mrad<sup>2</sup>/bw(%).

Photon energy	keV	20–180	FWHM photon spot size z = 100 m	cm	4–40
Bandwidth (bw)	%	1–10	Peak brilliance	\$	10 <sup>18</sup> –10 <sup>19</sup>
Photon/shot within FWHM bw	10 <sup>5</sup>	0.05–1	Radiation pulse length	ps	0.7–1.5
Photon/s within FWHM bw	10 <sup>13</sup>	0.05–1	Linear/circular polarization	%	99
Source size	μm	20	Repetition rate	MHz	100
Source divergence	mrad	1–6	Pulse-to-pulse separation	ns	10

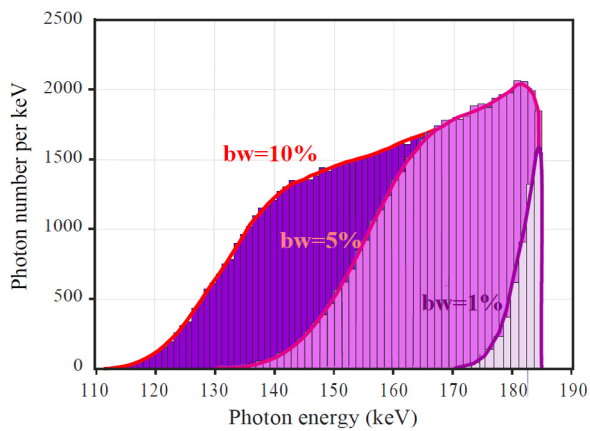

Fig. 3. Inverse Compton Scattering spectra. Photon yield as function of the photon energy. Collimation angles respectively 0.6, 2.1, 3.3 mrad for increasing bandwidths.

Table 3

Electron beam and undulator for MariX FEL.

Electron beam energy	GeV	1.6–3.8	Relative energy spread	$10^{-4}$	4–2
Charge	pC	8–50	Pulse duration	fs	2.5–16
Current	kA	1.5–1.8	Undulator period	cm	1.2–2.8
Normalized emittance	mm mrad	0.4–0.6	Undulator length	m	30–60

The concept of the ICS high-flux Compton Source is to enable advanced radiological imaging applications to be conducted with monochromatic X-rays. These applications range from higher sensitivity in mammography to higher contrast in edge enhancement base radio-imaging with phase contrast, to selective radio-therapy with Auger electrons triggered inside tumoral cells by mono-chromatic photon beams, and are made possible only when the flux of the ICS source reaches  $10^{13}$  photons/s as foreseen in MariX/BriXS, with an expected bandwidth of 1%–10% (see Table 2). Fig. 3 presents the collimated spectrum of the Compton radiation produced in one single interaction between laser and electron beam with parameters as those listed in Table 1. Cases relevant to different collimation angles and bandwidths are presented.

Beam nominal values and radiation characteristics for the MariX FEL are summarized respectively in Tables 3 and 4. The FEL source is tailored for time-resolved spectroscopies with coherent X-rays providing individual pulses not exceeding the linear response regime and space charge effects. This implies  $10^8$  photons per 10 fs-long pulses

Table 4

MariX FEL characteristics,  $\$ = \text{Photons/s/mm}^2/\text{mrad}^2/\text{bw}(\%)$ .

Undulator		UliX1	UliX2
Photon energy	keV	0.12–1.5	1.5–8
Radiation wavelength	Å	100–8	8–1.5
Photon/shot	$10^{11}$	17–1.2	2.4–0.025
Bandwidth	0.1%	2.1–0.7	2.3–3
Pulse length	fs	3–10	1–7
Pulse divergence	μrad	6–50	16–45
Photon/s	$10^{17}$	17–1.2	2.4–0.025
Average brilliance	$10^{23}$ $\$$	0.86–14	3.5–0.37

which is at most 3–4 orders of magnitude lower than the individual peak intensity of the current X-FELs. The 4–5 orders of magnitude gain in repetition rate provided by MariX, e.g. at 1–2 MHz, restores the high average flux of the most advanced synchrotron sources, whilst having ultrashort pulses suitable for time resolved pump-probe methods in optical, photoelectric effect and inelastic X scattering experiments. With the current FEL technology, a  $10^3$ – $10^4$  attenuation of X-ray beams must be applied (as at e.g. SACLA), in order to measure an undistorted, non energy-shifted core level spectrum. The statistics of these measurements is limited, by the 30–50 Hz operation, to a  $10^5$  lower time integrated flux per second with respect to MariX. High longitudinal coherence will enable pump-probe methods at 10–100 fs accuracy and with high statistics.

In the wavelength range between 2 and 5 Å (5–2 keV), the simulations of the MariX FEL forecast, at the exit of the undulator, either  $10^{10}$ – $10^{11}$  photons per shot with a repetition rate of 1 MHz in SASE mode or  $10^9$ – $10^{10}$  photons per shot in single spike SASE mode and in cascaded seeded configuration. These evaluations exceed by one or two orders of magnitude the target value of  $10^8$  set by the scientific case. They are, however, the result of tight optimizations along the whole beam and photon lines and do not take into account any degradation due to errors, misalignments or jitters. It is moreover necessary to account for a further safety margin in the number of photons because of the transport radiation losses between the undulator exit and the user's stations in the experimental hutch. Considering that all these depletion factors produce a decrease in the photon number by one or two orders of magnitude, MariX will be therefore capable to satisfy the requested FEL photon beam parameters expected by the envisaged experiments. A further innovation is a truly coherent photon beam at 100 KHz, that can be obtained with the cascaded High Gain Harmonics Generation (HGHG) fresh bunch technique [19]. Precision timing measurements will actually benefit from this option, as the SASE intrinsic pulse-to-pulse jitter, as well as the reduced pulse-to-pulse intensity fluctuations,

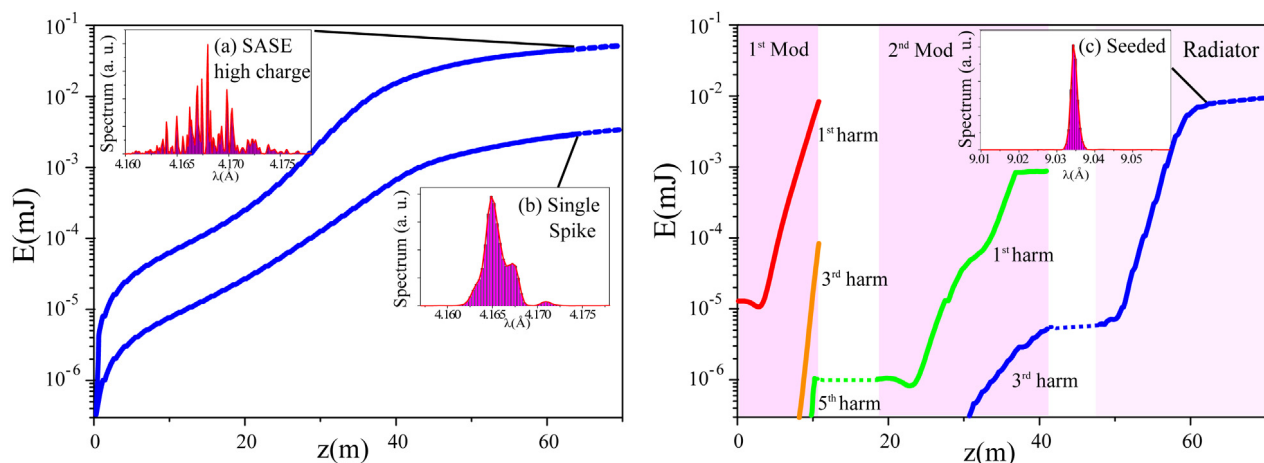
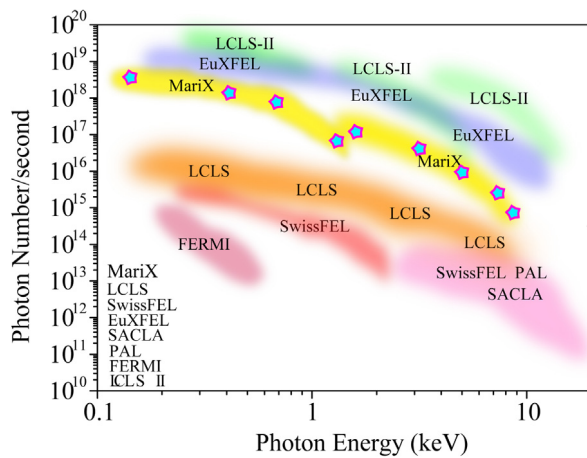

Fig. 4. FEL radiation energy vs undulator position and spectra (in the boxes) extracted at 60 m. Left window: (a) SASE case obtained in UliX2 with  $Q = 50$  pC. (b) SASE single spike, same parameters as (a), but  $Q = 8$  pC. Right window: (c) Seeded cascaded fresh-bunch case. First modulator (1st Mod) with 5 cm period. Second modulator (2nd Mod) with 2.8 cm period. Radiator with 1.2 cm period. The FEL simulations have been performed with GENESIS 1.3 [14].



**Fig. 5.** The expected performances of MariX Free Electron Laser (yellow area), in terms of photon flux as a function of the photon energy in the 0.2–8 keV anticipated dynamic range, showing performances above present FELs driven by normal conducting Linacs, second only to the anticipated performances of LCLS-II and EuXFEL. (For interpretation of the references to color in this figure legend, the reader is referred to the web version of this article.)

will be substantially eliminated, thus approaching, at hard X-ray energies, the unique performance of FERMI. Typical FEL spectra for linear spectroscopy applications are presented in Fig. 4. Case (a) has been obtained with UliX2 and the largest possible charge (50 pC) at 4.17 Å and presents SASE spectral fluctuations. Case (b) is an example of SASE single spike mode [20], with improved coherence, obtained in the same condition as case (a), but with lower charge (8 pC). True coherence and pulse stability can be achieved with a segmented undulator, by means of cascaded fresh-bunch seeding technique. The relatively low value of electron energy permits to limit the detrimental effect of the shot noise on the seeded emission. Other effects affecting the emission quality that could arise during the beam transport, like the microbunching instability or coherent synchrotron radiation (CSR) can be taken under control by the insertion of a Laser Heater downstream of the cathode or of a collimator upstream of the undulator. The seed is about 12 nJ at 13.7 nm radiation and can be generated by HHG in gas [21] or with a dedicated FEL oscillator [22]. In the example shown in Fig. 4 (case c), performed at  $\lambda = 9$ , three undulator modules (with periods respectively 5 cm, 2.8 cm and 1.2 cm) are foreseen.

Such source will fill in the XAS/XMCD (with polarization control from quarterwavelength blades or undulators) and bulk photoemission to become highly efficient probes of matter at the nanoscale but in bulk environments, like buried interfaces of interest in materials science, in-vivo biological samples or catalysers at work. The novel source will therefore create absolutely novel conditions for experiments that cannot be performed satisfactorily at the present and foreseen sources based on storage rings or SASE-FEL. The anticipated performances of MariX Free Electron Laser are well beyond the state of the art of presently FELs in operation, and in the trailing edge of EuXFEL and of the US future superconducting FEL project of reference (LCLS-II) as illustrated in Fig. 5.

#### 4. Conclusions

A new generation accelerator complex is at the core of the MariX facility dedicated and optimized to ultrafast coherent-X-ray spectroscopy

and inelastic photon scattering, and to highly penetrating X-ray imaging of mesoscopic and macroscopic samples. Such facility will be intrinsically multi-user and multidisciplinary as of the research performed and science output. The Conceptual Design Report is available for download at the address <http://www.fisica.unimi.it/ecm/home/ricerca/marix>.

#### Acknowledgments

Useful comments by M. Altarelli, A. Gallo, A. Ghigo, L. Giannessi, J. Hastings and A. Variola are gratefully acknowledged. One of the authors, S. Samsam, is supported by a ICTP fellowship, Italy under the TRIL program.

#### References

- [1] P. Emma, R. Akre, et al., First lasing and operation of an ångstrom-wavelength free-electron laser, *Nat. Photon.* 4 (2010) 641.
- [2] Tetsuya Ishikawa, Hideki Aoyagi, et al., A compact X-ray free-electron laser emitting in the sub-ångström region, *Nat. Photon.* 6 (2012) 540.
- [3] H. Weise, W. Decking, Commissioning and first kasing of the European XFEL, in: *Proceedings FEL2017, MOC03*, 2017.
- [4] C.J. Milne, SwissFEL: The swiss X-ray free electron laser, *Appl. Sci.* 7 (2017) 720.
- [5] In Soo Ko, Heung-Sik Kang, et al., Construction and commissioning of PAL-XFEL facility, *Appl. Sci.* 7 (5) (2017) 479; H.S. Kang, et al., Hard X-ray FEL lasing through BBA and radiation spectrum analysis, in: *Proceedings of IPAC2017, JACoW*, 2017.
- [6] D. Wang, SXFEL team, Soft X-ray free-electron laser at SINAP, in: *Proceedings of IPAC2016 TUZA01*, 2016.
- [7] T. Raubenheimer, LCLS-II-HE FEL facility overview, 2016, [https://portal.slac.stanford.edu/sites/conf\\_public/lclsiihe2016/Documents/160926%20LCLS-II-HE%20Raubenheimer.pdf](https://portal.slac.stanford.edu/sites/conf_public/lclsiihe2016/Documents/160926%20LCLS-II-HE%20Raubenheimer.pdf).
- [8] <https://www.lanl.gov/science-innovation/science-facilities/marie/index.php>.
- [9] B. Faatz, S. Schreiber, et al., First lasing of FLASH2 at DESY, *Synchrotron Radiat. News* 27 (2014) 37.
- [10] E. Allaria, R. Appio, et al., Highly coherent and stable pulses from the FERMI seeded free-electron laser in the extreme ultraviolet, *Nat. Photon.* 6 (2012) 699; E. Allaria, et al., Two-stage seeded soft-x-ray free-electron laser, *Nat. Photon.* 7 (2013) 913–918.
- [11] S. Di Mitri, M. Cornacchia, Transverse emittance-preserving arc compressor for high brightness electron beam-based light sources and colliders, *Europhys. Lett.* 109 (2015) 62002; S. Di Mitri, Feasibility study of a periodic arc compressor in the presence of coherent synchrotron radiation, *Nucl. Instrum. Methods Phys. Res. A* 806 (2016) 184.
- [12] M. Placidi, et al., Compact FEL-driven inverse Compton scattering gamma-ray source, *Nucl. Instrum. Methods Phys. Res. A* 855 (2017) 5560. <https://www.elettra.trieste.it/lightsources/elettra>.
- [13] S. Reiche, GENESIS 1.3: a fully 3D time-dependent FEL simulation code, *Nucl. Instrum. Methods Phys. Res. A* 429 (1999) 243.
- [14] K. Floettmann, ASTRA: A space charge tracking algorithm. URL: <http://www.desy.de/~mpyflo/>.
- [15] L.M. Young, J. Billen, PARMELA-code, Tech. Rep. LA-UR-96-1835, 1998, Revised May 4.
- [16] M. Borland, et al., Elegant, Tech. Rep. LS-287, ANL, Argonne, IL, 2000.
- [17] P. Chen, et al., CAIN: Conglomerat d'ABEL et d'Interactions Non-lineaire, *Nucl. Instrum. Methods Phys. Res. A* 355 (1995) 107.
- [18] I. Ben-Zvi, K.M. Yang, L.H. Yu, The fresh-bunch technique in FELs, *Nucl. Instrum. Methods Phys. Res. A* 318 (1992) 726.
- [19] J. Rosenzweig, et al., *Nucl. Instrum. Methods Phys. Res. A* 593 (2008) 39.
- [20] E.J. Takahashi, et al., High-order harmonic generation by an ultrafast infrared pulse, *IEEE J. Sel. Top. Quantum Electron.* 10 (2004) 1315; G. Lambert, et al., *New J. Phys.* 11 (2009) 083033.
- [21] G. Dattoli, E. Di Palma, A. Petralia, Free electron laser oscillator efficiency, *Opt. Commun.* 425 (2018) 29; A. Kai Li, Jiawei Yan, Chao Feng, Meng Zhang, Haixiao Deng, High brightness fully coherent X-ray amplifier seeded by a free-electron laser oscillator, *Phys. Rev. Accel. Beams* 21 (2017) 040702.