

Abu Tbeirah Excavations I. Area 1

Last Phase and Building A – Phase 1

edited by
Licia Romano and Franco D'Agostino

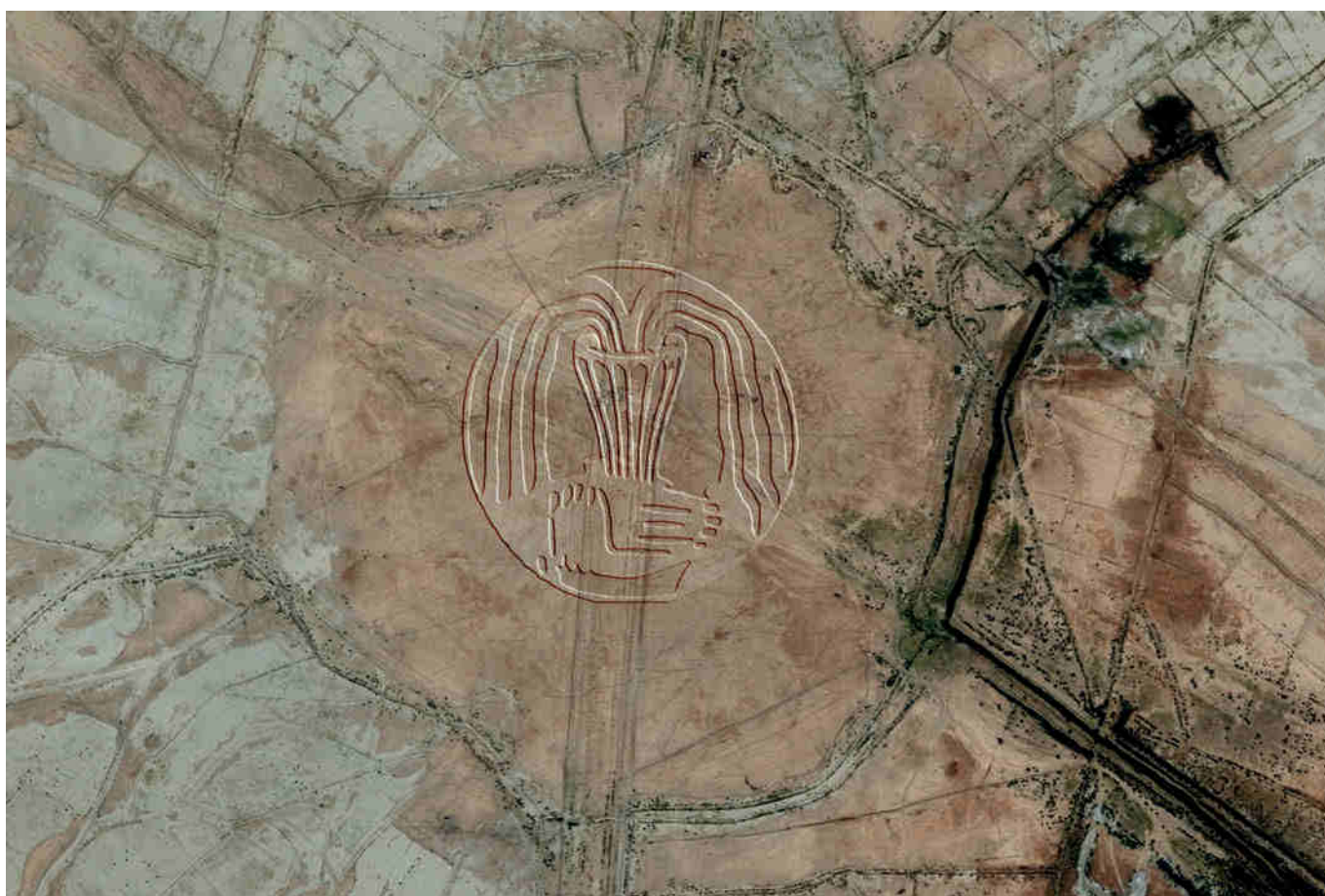

Collana Materiali e documenti 44

Abu Tbeirah
Excavations I. Area 1
Last Phase and Building A – Phase 1

edited by
Licia Romano and Franco D'Agostino



SAPIENZA
UNIVERSITÀ EDITRICE
2019



STATE BOARD FOR ANTIQUITIES
& HERITAGE, IRAQ

Copyright © 2019

Sapienza Università Editrice
Piazzale Aldo Moro 5 – 00185 Roma

www.editricesapienza.it
editrice.sapienza@uniroma1.it

Iscrizione Registro Operatori Comunicazione n. 11420

ISBN 978-88-9377-108-5

DOI 10.13.133-9788893771085

Pubblicato giugno 2019



Quest'opera è distribuita
con licenza Creative Commons 3.0
diffusa in modalità *open access*.

*This book is dedicated to Amir Doshi,
whose friendship is the pillar
of our work at Abu Tbeirah*

Table of Contents

1. Foreword (F. D’Agostino - L. Romano)	1	5.3 Results	54
1.1 Registering Systems	5	5.3.1 Archaeological Sites	54
1.2 Acknowledgments	5	5.3.2 Palaeochannels	54
1.3 Members of the Excavation Campaigns at Abu Tbeirah	7	5.3.3 “Hollow Ways”	54
2. Let’s Dig It! The Story of Abu Tbeirah in the Vicinity of Ur (A. Hamdani)	9	5.3.4 Grooves	54
3. Geology and Palaeoenvironment of Nasiriyah Area/Southern Mesopotamia (S. Milli - L. Forti)	19	5.3.5 Crevasse Splays	54
3.1 Geomorphology	21	5.4 Conclusions	54
3.2 Geological Setting	23	References	57
3.3 The Quaternary Deposits	24	6. Abu Tbeirah and Area 1 in the Second Half of the 3 rd Mill. BC (L. Romano)	59
3.4 The Holocene Stratigraphy and Sedimentology of the Southern Mesopotamian Plain	26	6.1 Abu Tbeirah: Overview of the Site	61
3.5 Stratigraphy of the Nasiriyah Sector	31	6.1.1 Post-Depositional Alterations and Taphonomic Agents	64
References	33	6.2 Cemetery and Other Activities	66
4. Palaeoenvironment, Climate and Land Use in Southern Mesopotamia/Nasiriyah Area (A. Celant - D. Magri)	39	6.2.1 Cemetery or Sub-Pavimental Burials?	66
4.1 The Mesopotamian Palaeoenvironment	41	6.2.2 Abu Tbeirah’s Burial Practices	68
4.2 The 4.2 ka BP Event	43	6.2.3 Insights into the ED III - Akk. Funerary Practices	72
4.3 The Abu Tbeirah Plant Remains: Preliminary Insights	45	6.3 Building A	76
References	46	6.3.1 Building Techniques and Materials	77
5. The Environment and Landscape Archaeology of the Abu Tbeirah Region (J. Jotheri)	49	6.3.2 Plan, Circulation System and Natural Lighting	78
5.1 Introduction	51	6.3.3 Fire Installations and Artificial Illumination of the Building	79
5.2 Methodology	53	6.3.4 Sub-Pavement Graves	81
5.2.1 Remote Sensing	53	6.3.5 Dog (Ritual?) Deposition	82
5.2.2 Groundtruthing	53	6.3.6 Rooms Function(s) and Building A Household	83

6.4	Area 1: Towards an Abandonment Time-Line	84	8.2	Room 2	196
6.5	Future Perspectives	86	8.3	Room 3	205
	References	87	8.4	Room 4	206
7.	Area 1: Cemetery and Other Activities (L. Romano - A.K. Ghanim)	93	8.5	Room 5	214
7.1	Mc-fXIII1-4	95	8.6	Room 6	220
7.1.1	Other Activities	95	8.7	Room 7	222
7.1.2	Grave 1	109	8.8	Room 8	225
7.1.3	Grave 2	112	8.9	Room 9	231
7.1.4	Grave 3	114	8.1	Room 10	236
7.1.5	Grave 6	116	8.11	Room 11	238
7.1.6	Grave 11	122	8.12	Room 12	243
7.2	MdXIII5+6+MeXIII5	126	8.13	Room 13	245
7.2.1	Grave 15	126	8.14	Room 14-15	250
7.2.2	Grave 16	133	8.15	Room 16	258
7.2.3	Other Activities	141	8.16	Room 17+19+21	262
7.3	Mb-cXIII5	158	8.17	Room 18	266
7.3.1	Grave 22	158	8.18	Room 20	268
7.4	Mb-dXIII6-7	165	8.19	Room 22	269
7.4.1	Other Activities	165	8.20	Room 23	271
7.4.2	Grave 17	169	8.21	Building A North-Western Outside	277
7.4.3	MdXIII7	173	9.	Micro-Debris Analysis of Building A - Phase 1 Room 23 (S. Cereda)	311
7.5	MdXIII6+MeXIII5+6	174	9.1	Introduction	313
7.5.1	Other Activities	174	9.2	Use of Space and Microscopic Record	313
7.6	MfXIII3-5	179	9.3	Data Acquisition and Processing	314
7.6.1	Other Activities	179	9.4	Results of Micro-Debris Analysis	315
7.6.2	Grave 21	179	9.5	Discussion of Results and Interpretation of Room 23	318
7.6.3	Grave 23	181	9.6	Conclusions	320
7.7	Mg-hXIII5-4	182		References	322
7.7.1	Grave 24	182	10.	Area 1 Pottery - Part 1: A Preliminary Assessment on Typology, Technology and Use (L. Romano - M. Zingale)	323
8.	Building A - Phase 1 (L. Romano - T. al-Hosseini)	189	10.1	Introduction	325
8.1	Room 1	191	10.2	Methodology	326

10.3	Typology	327	12.2.1	Description of the Burials and Preliminary Osteological Information	393
10.3.1	Open Shapes	327	12.3	Sub Pavimental Graves of Building A - Phase 1	398
10.3.2	Closed Shapes	335	12.3.1	Description of the Burials	398
10.3.3	Miscellaneous Vessels	339	12.4	Preliminary Osteological Notes	401
10.3.4	List of Pottery Vessels Considered in the Envelopes	341	12.5	The Isotopic Investigation	402
10.4	Shaping and Manufacturing Process	342	12.5.1	Stable Carbon and Nitrogen Isotopes	402
10.4.1	Insights into the Production of the Main Pottery Shapes	342	12.5.2	Strontium Isotopes Ratio	404
10.4.2	Surface Treatments and Decorations	355	12.6	Concluding Remarks	404
10.5	Use and Re-Use	360		References	405
10.6	Conclusions	362	13.	Faunal Remains (F. Alhaique)	419
	References	365	13.0	General Introduction	421
11.	Area 1 Pottery - Part 2: Clay, Fabrics and Firing Technology (G. Festa - V. Forte - L. Romano)	371	13.1	Area 1 Cemetery and Latest Activities	421
11.1	Introduction	373	13.1.1	Introduction	421
11.2	Mesopotamian Clay Sources	373	13.1.2	Grave 1	422
11.3	Macroscopic Classification of Ceramic Pastes	375	13.1.3	Grave 2	422
11.3.1	Selected Fragments	376	13.1.4	Grave 3	422
11.4	Neutron Investigations: Results and Discussion	378	13.1.5	Grave 6	422
11.4.1	Neutron Diffraction	378	13.1.6	Grave 11	422
11.4.2	Neutron Resonance Capture Analysis	379	13.1.7	Grave 15	422
11.4.3	Classification of the Samples on the Basis of the ND and NRCA	379	13.1.8	Grave 16	422
11.4.4	Autoptic V/S Neutron Classification	382	13.1.9	Grave 17	423
11.5	Insights into the Clay Selection and Firing Process	383	13.1.10	Grave 21	423
	References	385	13.1.11	Grave 22	423
12.	The Human Remains (M.A. Tafuri)	389	13.1.14	Grave 25	424
12.1	Introduction	391	13.1.15	Pit Under Graves 15 and 16 (MdXIII5+6+MeXIII5)	424
12.2	Area 1 Cemetery	393	13.1.16	Mc-f XIII 1-4	425
			13.1.17	MdXIII6+MeXIII5+6	425
			13.1.18	Mb-dXIII6-7	426
			13.1.19	Discussion - Cemetery and Latest Activities	426
			13.2	Area 1 Building A - Phase 1	426

13.2.1	Introduction	426	14.3	Raw Materials	442
13.2.2	Room 1	428	14.3.1	Artifacts Patination	443
13.2.3	Room 2	429	14.3.2	Preliminary Data About Chert Petrography	444
13.2.4	Room 3	429	14.3.3	Chert Availability in Southern Mesopotamia	444
13.2.5	Room 4	429	14.4	Blade Production	445
13.2.6	Room 5	429	14.4.1	Knapping Technique	446
13.2.7	Room 6	430	14.4.2	Technical Blades	447
13.2.8	Room 7	430	14.5	Sickle Production	447
13.2.9	Room 8	430	14.5.1	Retouch	447
13.2.10	Room 9	430	14.5.2	The Sickle Fragment from Building A - Room 23	448
13.2.11	Room 10	430	14.6	Conclusions	450
13.2.12	Room 11	430		References	451
13.2.13	Room 12	431	15.	Chipped Stone Artifacts: Use Wear Analysis (D. D'Errico)	455
13.2.14	Room 13	431	15.1	Introduction	457
13.2.15	Room 14 and Room 15	431	15.2	Results from Building A - Phase 1 Chert Tools	458
13.2.16	Room 16	432	15.3	The Sickle Elements of the Bitumen Handle AbT.15.114 (Building A - Phase 1 - Room 23)	459
13.2.17	Rooms 17+19+21	432	15.4	Conclusions	460
13.2.18	Room 18	432		References	462
13.2.19	Room 20	432	16.	Abu Tbeirah: A Philological and Epigraphic Point of View (F. D'Agostino - A. Greco)	463
13.2.20	Room 22	432	16.1	Premise	465
13.2.21	Room 23	433	16.2	The Water System of Abu Tbeirah	465
13.2.22	Outside Building A North-Western Side	433	16.3	Literary Compositions Describing Routes in the Proximity of Ur	467
13.2.23	Discussion - Building A - Phase 1	434	16.4	Cities in the Vicinity of Ur	468
13.3	Conclusion - Faunal Remains from Area 1	435	16.4.1	Enegir	469
	References	437	16.4.2	Kiabrig	470
14.	Chipped Stone Artifacts: Technological Analysis (D. Moscone)	439			
14.1	Introduction	441			
14.2	Composition of the Lithic Assemblage	441			

16.4.3	Ĝešbanda	471
16.4.4	Ga'eš	472
16.4.5	Aššu/Eššu	473
16.5	Conclusions	473
	Appendix. Fragments of Tablets and Inscribed Bricks from AbT	474
	References	476

CHAPTER 8

BUILDING A - PHASE 1



CHAPTER 8 BUILDING A - PHASE 1

Licia Romano
Sapienza University of Rome
Department “Institute of Oriental Studies”
licia.romano@uniroma1.it

Taher al Hosseini
Manager of Dhi-Qar Province
Iraqi State Board of Antiquities and Heritage
tahiralhossany1989@gmail.com

8.1 ROOM 1 [LR]¹

The first phase of occupation in Room 1 was characterized by a beaten earth floor (US 49) and a circular fireplace (US 48; -0.12 m).

The Room was filled by a stratum (US 53) of compact clay soil with small pieces of reed-mat and traces of ashes in the area near the fireplace.²

On the pavement several objects connected with food preparation were found: two grindstones (AbT.12.116-117) and a multi-functional stone tool (AbT.12.112). Moreover, along the north-eastern wall a big dish was found *in situ* (AbT.12.53.17), laying upside-down with several fish-bones under it (see Figs 8.1-2 and Fig. 13.9).³ The pottery found on the floor includes a beaker (AbT.12.53.16) along the south-east wall, near the stone tool.

The pavement was cut by a pit (US 62-63; elevation of the edge of the cut -0.17 m; elevation of the bottom of the pit -0.3 m), filled by a sandy-clay soil and fragments of mud-bricks, containing one almost entire burnt mud-brick and a grindstone.⁴



Fig. 8.1 Room 1 as seen from north-east.

¹ § 8 is written by L. Romano. We acknowledge the fundamental help of Taher al Hosseini in the excavation of Abu Tbeirah. In the catalogue of the finds of each context the abbreviation “[SC]” indicates that the description was written by Stefano Caruso. The references quoted in the text are reported at the end of § 6. See §§ 12-13 for the detailed analyses and description of the human and faunal remains.

² The filling contained several pottery fragments mostly belonging to drinking vessels (at least 7 beakers and 6 conical bowls), the bases of a ring and a convex jars, a wall fragment with an impressed ridge and coarse pottery fragments of the same big vessel (vat?). In most of the cases the fragments were mixed to the soil, hence it was difficult to ascertain if they were in primary or secondary deposition. The findings on the pavement were highlighted on the plan (Fig. 8.2).

³ In the earlier phase of the same room another fireplace was found surrounded by some post-holes: these post-holes could be related to a sort of wooden structure similar to those in the marshes used for cooking fish (D’Agostino *et al.* 2013: 75-76).

⁴ D’Agostino *et al.* 2013: 79-80.

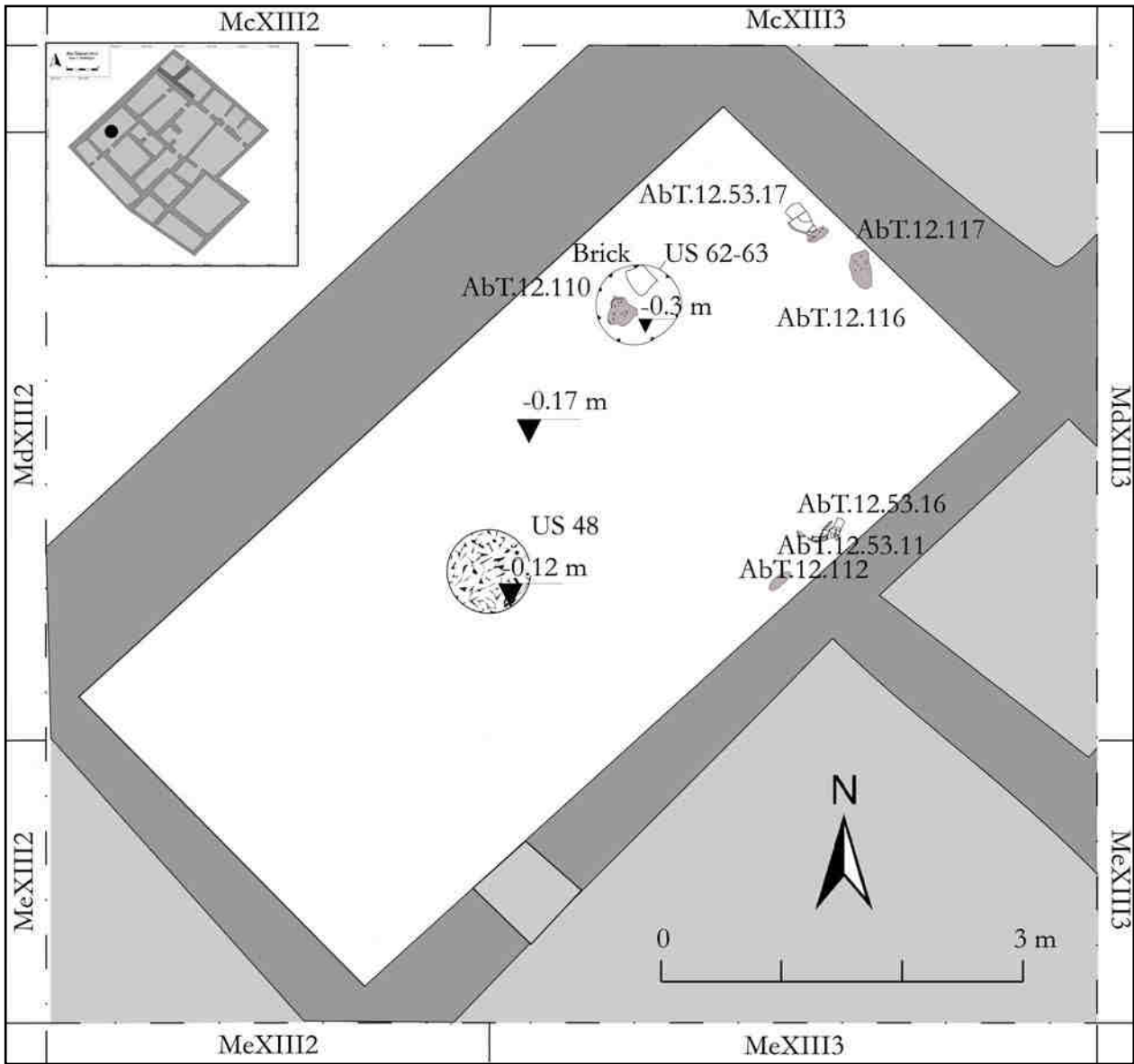

Fig. 8.2 Room 1 plan.

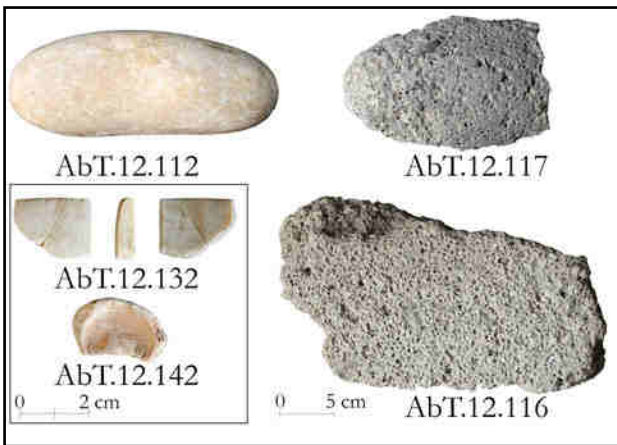

Fig. 8.3 US 53 objects.

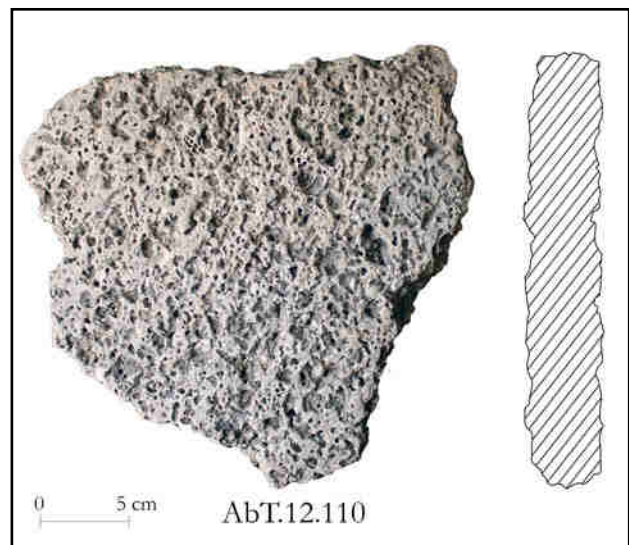

Fig. 8.4 US 63 objects.

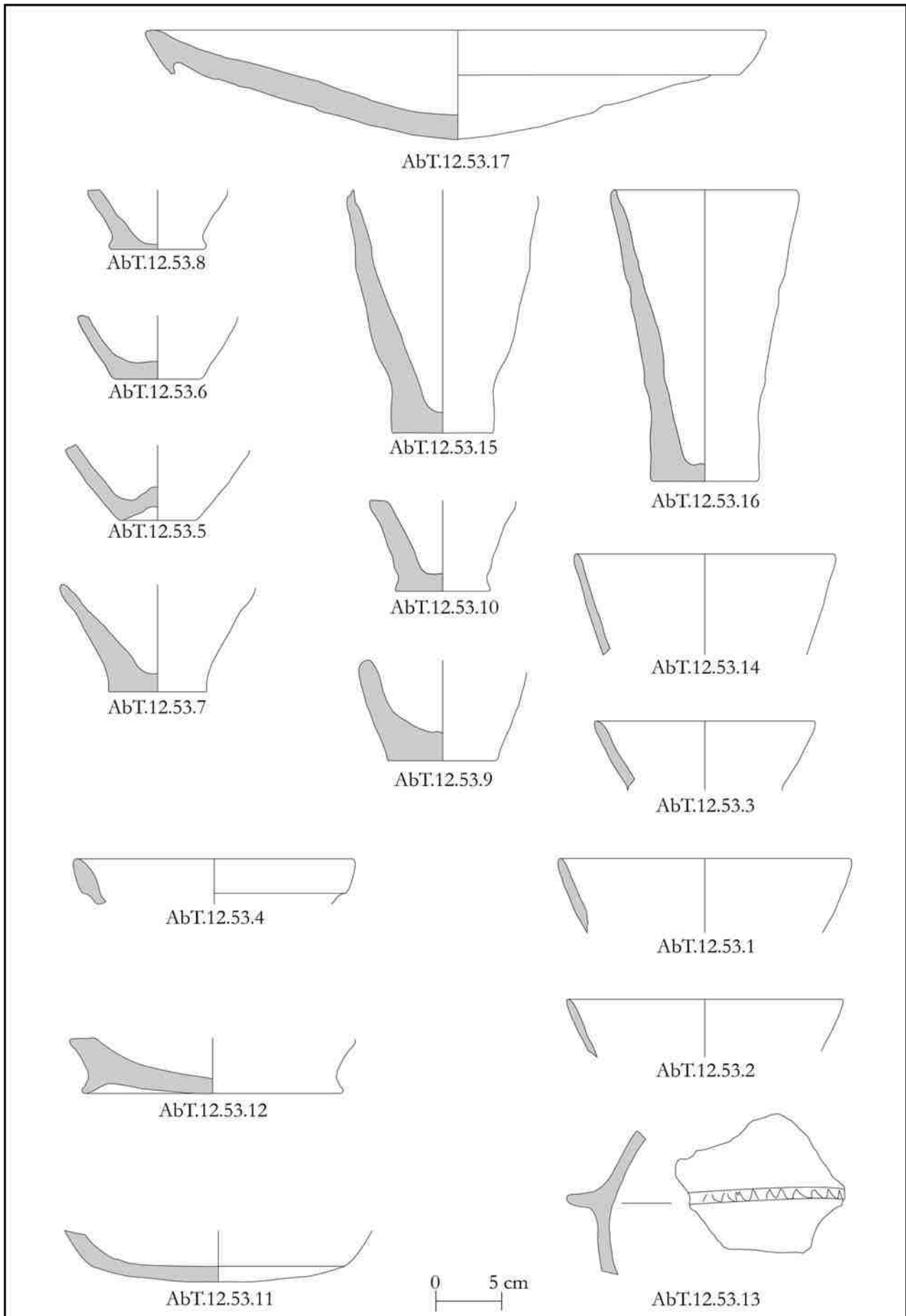

Fig. 8.5 US 53 pottery.

Catalogue of US 53 Finds

*Objects***AbT.12.112 - Fig. 8.3**

Description: hammer-stone with traces of use both on a lateral side and on the bottom surface. One of the sides is shaped by use. Traces of bitumen. [SC]
Dimensions: 1.5x22x8 cm.

AbT.12.116 - Fig. 8.3

Description: fragment of a grindstone.
Dimensions: 15.5x32x7 cm.

AbT.12.117 - Fig. 8.3

Description: half basalt grindstone.
Dimensions: 7.5x12.1x3.8 cm.

AbT.12.132 - Fig. 8.3

Description: fragment of a white marble stone vessel with indented decoration on the rim.
Dimensions: 1.7x2.2x0.4 cm.

AbT.12.142 - Fig. 8.3

Description: fragment of a pure clay object (no impression preserved).
Dimensions: 2.6x1.77x0.73 cm.

Catalogue of US 63 Finds

*Objects***AbT.12.110 - Fig. 8.4**

Description: grindstone fragment.
Dimensions: 25.5x25x3.8 cm.

*Pottery***AbT.12.53.1 - Fig. 8.5**

Dimensions: rim diam.: 16.6 cm; rim th.: 0.6 cm; wall th.: 0.8 cm.
Clay: outer, inner and fabric colour: 7.5YR 6/6 (reddish yellow); sand inclusions; medium-low firing temperature.
Description: drinking vessel rim.

AbT.12.53.2 - Fig. 8.5

Dimensions: rim th.: 0.6 cm; rim diam.: 15.6 cm; wall th.: 0.6 cm.
Clay: outer and inner colour: 2.5Y 7/3 (pale brown); fabric colour: 7.5YR 5/4 (brown); sand inclusions; medium-high firing temperature.
Description: drinking vessel rim.

AbT.12.53.3 - Fig. 8.5

Dimensions: rim diam.: 12.6 cm; rim th.: 0.7 cm; wall th.: 0.6 cm.

Clay: outer, inner and fabric colour: 2.5Y 7/3 (pale brown); sand inclusions; medium firing temperature.
Description: drinking vessel rim.

AbT.12.53.4 - Fig. 8.5

Dimensions: rim diam.: 17 cm; rim th.: 1 cm.
Clay: outer, inner and fabric colour: 2.5Y 7/3 (pale brown); sand inclusions; medium-high firing temperature.
Description: triangular rim jar.

AbT.12.53.5 - Fig. 8.5

Dimensions: wall th.: 0.7 cm; base diam.: 4.5 cm; base th.: 1.1 cm.
Clay: outer, inner and fabric colour: 5YR 5/6 (yellowish red); sand inclusions; medium-low firing temperature.
Description: conical bowl base.

AbT.12.53.6 - Fig. 8.5

Dimensions: wall th.: 0.8 cm; base diam.: 5 cm; base th.: 1 cm.
Clay: outer, inner and fabric colour: 5YR 5/6 (yellowish red); sand inclusions; medium-low firing temperature.
Description: conical bowl base.

AbT.12.53.7 - Fig. 8.5

Dimensions: wall th.: 0.8 cm; base diam.: 5.5 cm; base th.: 0.8 cm.

Clay: outer, inner and fabric colour: 5YR 5/4 (reddish brown); sand inclusions; medium-low firing temperature.

Description: conical bowl base.

AbT.12.53.8 - Fig. 8.5

Dimensions: wall th.: 0.75 cm; base diam.: 5 cm; base th.: 0.5 cm.

Clay: outer, inner and fabric colour: 5YR 5/4 (reddish brown); sand inclusions; medium-high firing temperature.

Description: conical bowl base.

AbT.12.53.9 - Fig. 8.5

Dimensions: wall th.: 1.3 cm; base diam.: 6.5 cm.

Clay: outer colour: 10YR 6/3 (pale brown); inner and fabric colour: 5YR 4/4 (reddish brown); sand inclusions; medium firing temperature.

Description: beaker base.

AbT.12.53.10 - Fig. 8.5

Dimensions: wall th.: 1 cm; base diam.: 5.5 cm; base th.: 0.3 cm.

Clay: outer, inner and fabric colour: 7.5YR 4/4 (brown); sand inclusions; medium firing temperature.

Description: beaker base.

AbT.12.53.11 - Fig. 8.5

Dimensions: wall th.: 1 cm; base diam.: 14.6 cm; base th.: 0.8 cm.

Clay: outer colour: 2.5Y 7/3 (pale brown); inner and fabric colour: 7.5YR 6/4 (light brown); sand inclusions; medium-high firing temperature.

Description: convex base.

AbT.12.53.12 - Fig. 8.5

Dimensions: base diam.: 14.6 cm; base th.: 1 cm.

Clay: outer colour: 2.5Y 7/3 (pale brown); inner and fabric colour: 5YR 5/6 (yellowish red); sand inclusions; medium-high firing temperature.

Description: ring base.

AbT.12.53.13 - Fig. 8.5

Dimensions: wall th.: 0.85 cm.

Clay: outer, inner and fabric colour: 5Y 7/3 (pale yellow); sand inclusions; medium firing temperature.

Description: wall with notched ridge.

AbT.12.53.14 - Fig. 8.5

Dimensions: rim diam.: 14.1 cm; rim th.: 0.4 cm; wall th.: 0.6 cm.

Clay: outer and inner colour: 10YR 8/2 (very pale brown); fabric colour: 7.5YR

6/4 (light brown); sand inclusions; medium-high firing temperature.

Description: drinking vessel rim.

AbT.12.53.15 - Fig. 8.5

Dimensions: wall th.: 0.85 cm; base diam.: 6 cm; base th.: 1.2 cm.

Clay: outer, inner and fabric colour: 5YR 4/4 (reddish brown); sand inclusions; medium firing temperature.

Description: beaker base.

AbT.12.53.16 - Fig. 8.5

Dimensions: rim diam.: 11 cm; rim th.: 0.5 cm; wall th.: 0.75 cm; base diam.: 6 cm; base th.: 1 cm; h.: 16 cm.

Clay: outer, inner and fabric colour: 5YR 5/6 (yellowish red); sand inclusions; medium firing temperature.

Description: beaker.

AbT.12.53.17 - Fig. 8.5

Dimensions: rim diam.: 35.4 cm; rim th.: 2; wall th.: 1.35 cm; base diam.: 16.2 cm; base th.: 1.4 cm.

Clay: outer and inner colour: 7.5YR 8/2 (pinkish white); fabric colour: 5YR 5/6 (yellowish red); sand inclusions; medium-high firing temperature.

Description: shallow plate with triangular rim and convex base. Fish bones found under it.

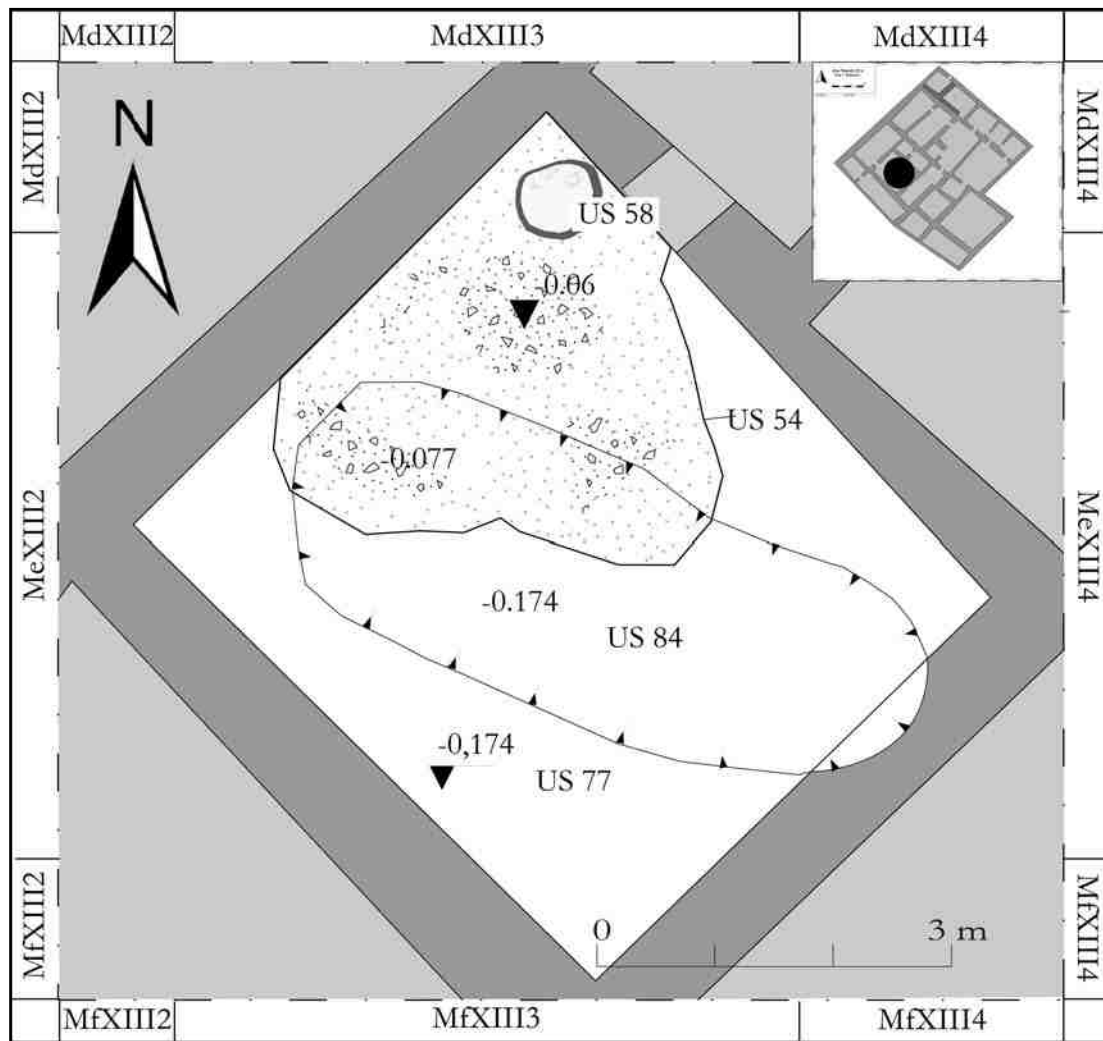

Fig. 8.6 Room 2 plan.

8.2 ROOM 2 [LR]

Room 2 last phase of occupation (Fig. 8.6) was partially excavated during the 2nd excavation campaign and completed in 2015. On the basis of the satellite imagery it was interpreted as a big courtyard⁵ but the 2015 excavations revealed an open space, though of significantly reduced dimensions. However, thanks to 2015 excavations the stratigraphy of the Room was verified and better defined. The Room was filled by an accumulation stratum (US 52) cut by several modern activities. This stratum covered the evidences of use of the Room: a tannur (US 58; Figs 8.7-8) was located in the north corner and surrounded by a heap of soil

mixed with a big quantity of ashes and elements connected to the use of the fire installation (US 54). The tannur was built partially by excavating the soil of the Room (or it was reused by digging deeper, the bottom, and repaired/rebuilt several times),⁶ using pottery fragments (mainly walls of jars) to reinforce the external walls. Four beakers (US 51) were found inside the tannur. Near the fire installation a sort of little passage along the north-east wall was closed with some mud-bricks of a lighter colour during this phase of occupation of the building.

The ground surface and the filling of Room 2 (US 77=400) were cut by a later pit (US 84=397; US 101=398).

⁵ See D'Agostino *et al.* 2013: 76. Apparently the satellite imagery showed here a big open space (white area compared to the darker traces left by the presence of the mud-brick structures): later activities on the area (probably an encampment) evened and compacted the surface easing the salt accumulation.

⁶ See for comparison Crafword 1981: 108-109.



Fig. 8.7 US 54 and the tannur US 58 before excavation.



Fig. 8.8 Tannur photographed in the Iraqi Marshes during 2013.



Fig. 8.9 US 52 objects.



Fig. 8.10 US 54 objects.

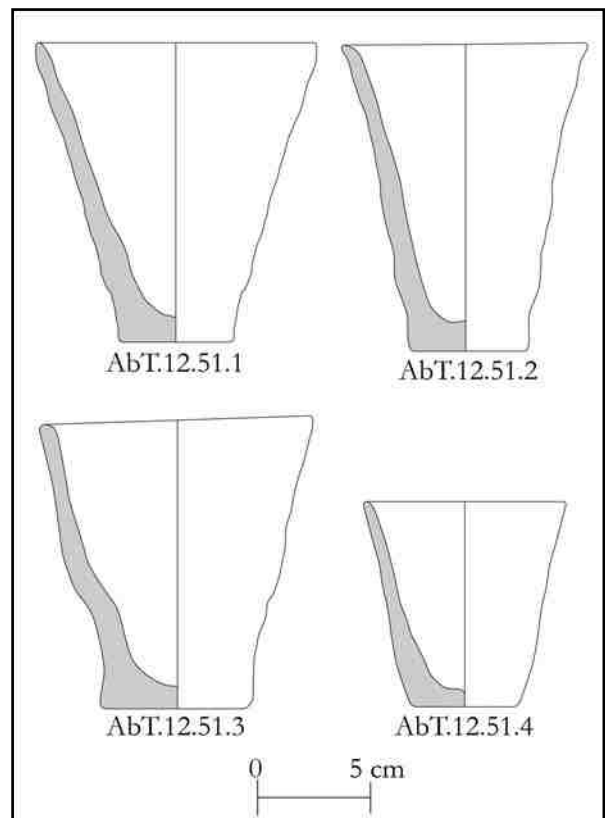

Fig. 8.11 US 51 pottery.

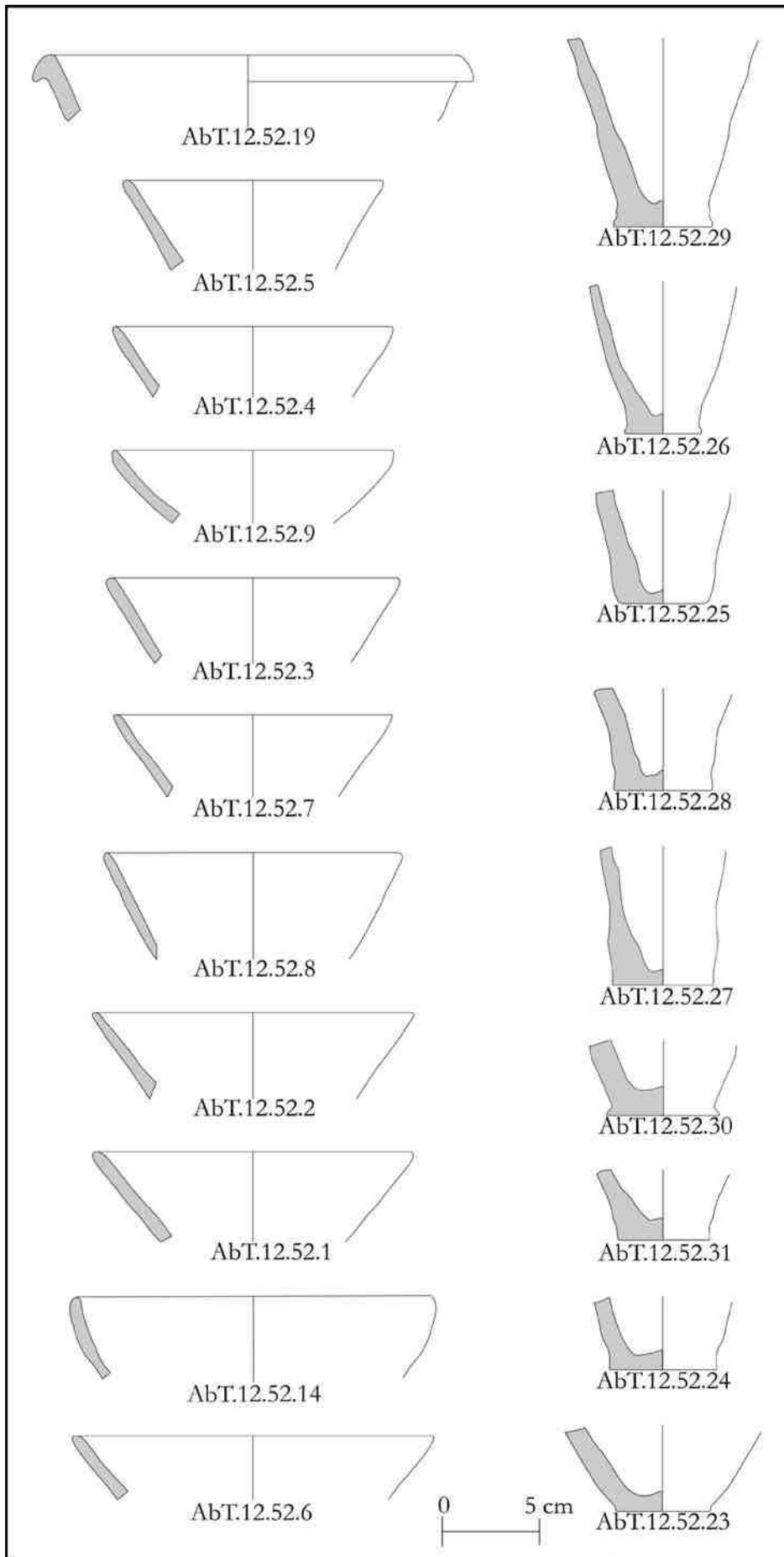

Fig. 8.12 US 52 pottery: open shapes.

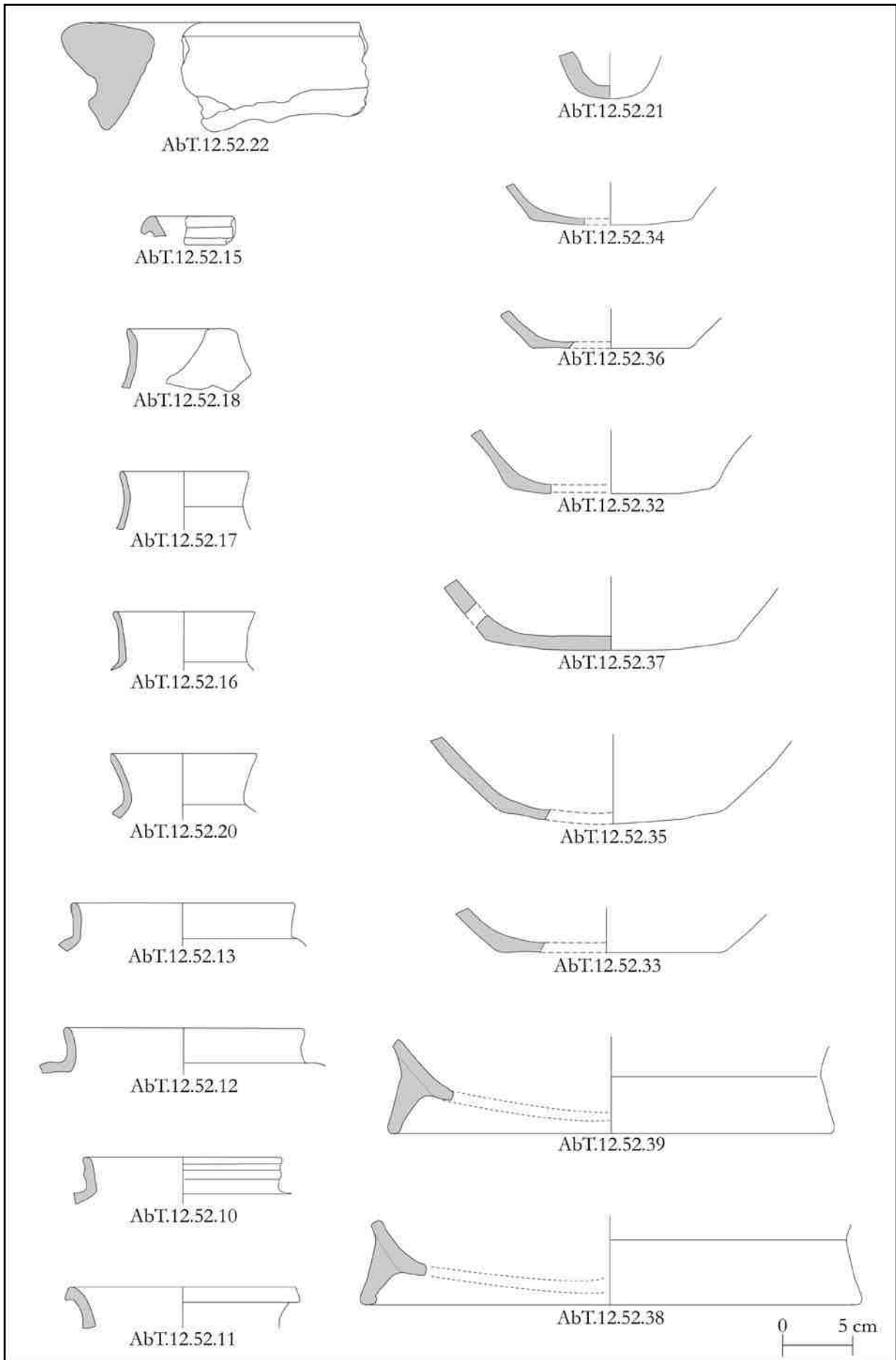

Fig. 8.13 US 52 pottery: closed shapes.

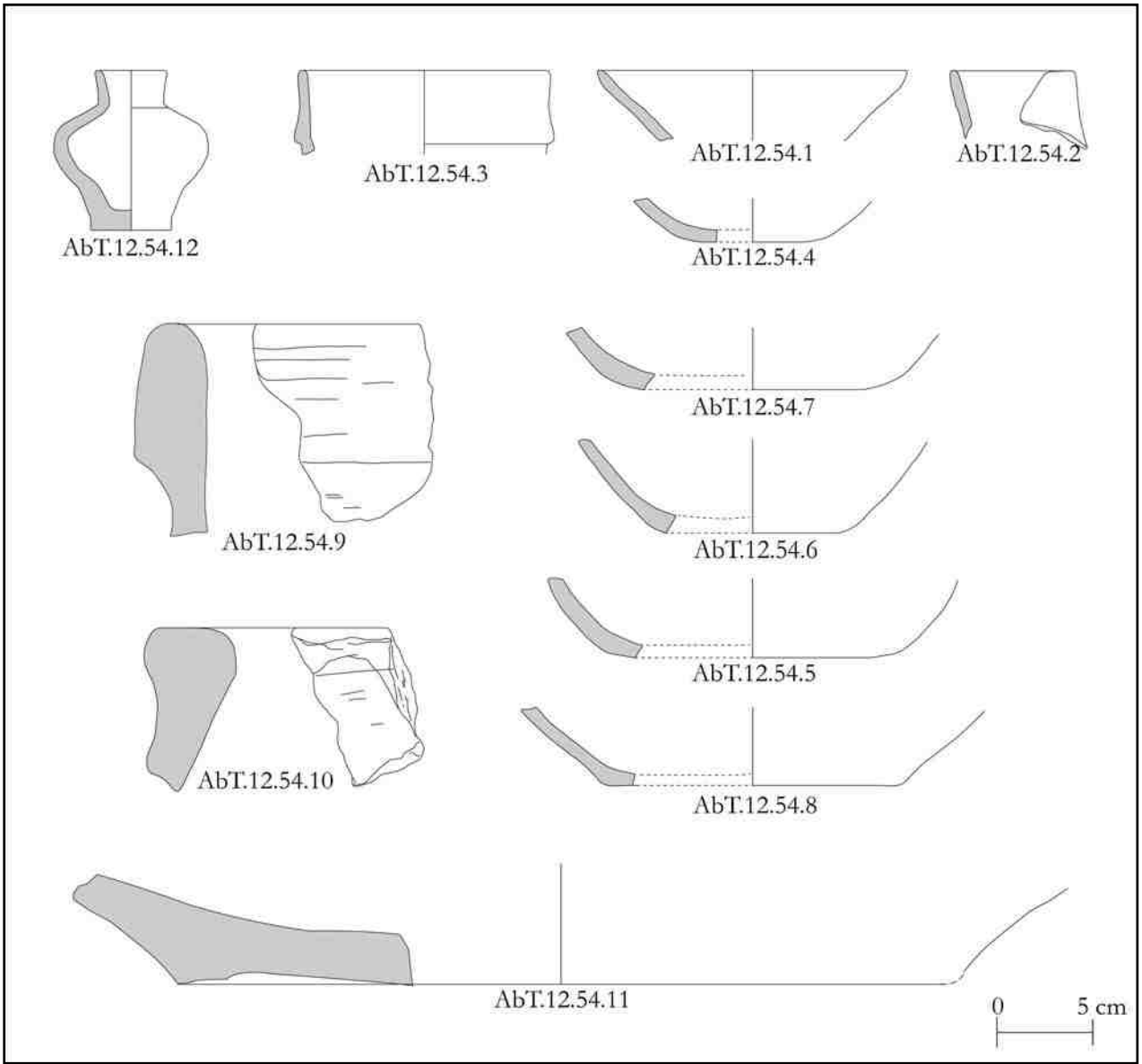

Fig. 8.14 US 54 pottery.

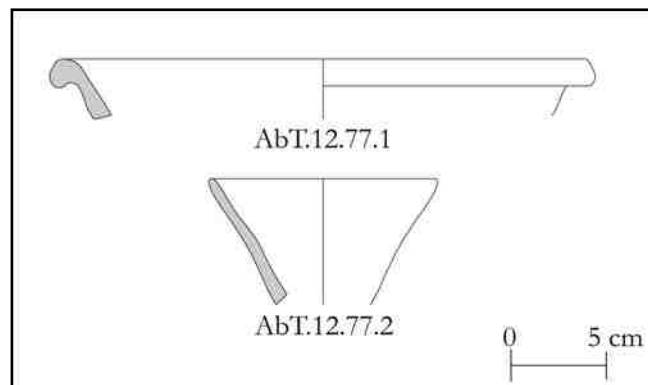

Fig. 8.15 US 77 pottery.

Catalogue of US 51 Finds

*Pottery***AbT.12.51.1 - Fig. 8.11**

Dimensions: rim diam.: 12.2 cm; rim th.: 0.6 cm; wall th.: 0.8 cm; base diam.: 5 cm; base th.: 1.2 cm; h.: 13.1 cm.

Clay: outer, inner and fabric colour: 10YR 8/3 (very pale brown); sand inclusions; medium-high firing temperature.

Description: beaker.

AbT.12.51.2 - Fig. 8.11

Dimensions: rim diam.: 10.6 cm; rim th.: 0.65 cm; wall th.: 0.75 cm; base diam.: 5.2 cm; base th.: 1.3 cm; h.: 13.5 cm.

Clay: outer, inner and fabric colour: 2.5Y 5/2 (greyish brown); sand inclusions; medium-high firing temperature.

Description: beaker.

AbT.12.51.3 - Fig. 8.11

Dimensions: rim diam.: 11.8 cm; rim th.: 0.8 cm; wall th.: 1.1 cm; base diam.: 6.2 cm; base th.: 1 cm; h.: 12.7 cm.

Clay: outer, inner and fabric colour: 2.5YR 4/4 (reddish brown); sand inclusions; high firing temperature.

Description: beaker.

AbT.12.51.4 - Fig. 8.11

Dimensions: rim diam.: 9 cm; rim th.: 0.35 cm; wall th.: 0.4 cm; base diam.: 4 cm; base th.: 0.6 cm; h.: 9 cm.

Clay: outer, inner and fabric colour: 5YR 5/3 (reddish brown); sand inclusions; medium firing temperature.

Description: beaker.

Catalogue of US 52 Finds

*Objects***AbT.12.135 - Fig. 8.9**

Description: chert blade.

Dimensions: 1.6x7.9x1.4 cm.

AbT.12.136 - Fig. 8.9

Description: red stone tool (hammer-stone?).

Dimensions: 10.5x4.5x19 cm

AbT.12.143 - Fig. 8.9

Description: chert sickle element.

Dimensions: 1.4x3.7x0.3 cm.

*Pottery***AbT.12.52.1 - Fig. 8.12**

Dimensions: rim diam.: 16 cm; rim th.: 0.7 cm; wall th.: 0.75 cm.

Clay: outer, inner and fabric colour: 5YR 6/6 (reddish yellow); sand inclusions; medium firing temperature.

Description: drinking vessel rim.

AbT.12.52.2 - Fig. 8.12

Dimensions: rim diam.: 16 cm; rim th.: 0.7 cm; wall th.: 0.8 cm.

Clay: outer colour: 10YR 8/3 (very pale brown); inner and fabric colour: 2.5YR 5/6 (red); sand inclusions; medium firing temperature.

Description: drinking vessel rim.

AbT.12.52.3 - Fig. 8.12

Dimensions: rim diam.: 14.5 cm; rim th.: 0.8 cm; wall th.: 0.8 cm.

Clay: outer colour: 7.5YR 8/3 (pink); inner and fabric colour: 5YR 5/6 (yellowish red); sand inclusions; medium firing temperature.

Description: drinking vessel rim.

AbT.12.52.4 - Fig. 8.12

Dimensions: rim diam.: 15 cm; rim th.: 0.6 cm; wall th.: 0.7 cm.

Clay: outer colour: 2.5Y 8/2 (pale brown); inner and fabric colour: 2.5YR 5/6 (red); sand inclusions; medium firing temperature.

Description: drinking vessel rim.

AbT.12.52.5 - Fig. 8.12

Dimensions: rim diam.: 13 cm; rim th.: 0.7 cm; wall th.: 0.8 cm.

Clay: outer colour: 10YR 8/2 (very pale brown); inner and fabric colour: 2.5YR 5/6 (red); sand inclusions; medium firing temperature.

Description: drinking vessel rim.

AbT.12.52.6 - Fig. 8.12

Dimensions: rim diam.: 18 cm; rim th.: 0.7 cm; wall th.: 0.7 cm.

Clay: outer colour: 10YR 8/2 (very pale brown); inner and fabric colour: 5YR 5/4 (reddish brown); sand inclusions; medium firing temperature.

Description: drinking vessel rim.

AbT.12.52.7 - Fig. 8.12

Dimensions: rim diam.: 14 cm; rim th.: 0.6 cm; wall th.: 0.7 cm.

Clay: outer and inner colour: 10YR 8/2 (very pale brown); fabric colour: 2.5YR

5/6 (red); sand inclusions; medium firing temperature.

Description: drinking vessel rim.

AbT.12.52.8 - Fig. 8.12

Dimensions: rim diam.: 15 cm; rim th.: 0.7 cm; wall th.: 0.6 cm.

Clay: outer colour: 10YR 8/2 (very pale brown); inner and fabric colour: 2.5YR 5/6 (red); sand inclusions; medium firing temperature.

Description: drinking vessel rim.

AbT.12.52.9 - Fig. 8.12

Dimensions: rim diam.: 14 cm; rim th.: 0.7 cm; wall th.: 0.6 cm.

Clay: outer colour: 10YR 8/2 (very pale brown); inner and fabric colour: 5YR 6/6 (reddish yellow); sand inclusions; medium-high firing temperature.

Description: drinking vessel rim.

AbT.12.52.10 - Fig. 8.13

Dimensions: rim diam.: 14 cm; rim th.: 0.6 cm; wall th.: 0.7 cm.

Clay: outer and inner colour: 2.5Y 8/2 (pale brown); fabric colour: 10YR 5/4 (yellowish brown); sand inclusions; medium-high firing temperature.

Description: double-ridged rim jar.

AbT.12.52.11 - Fig. 8.13

Dimensions: rim diam.: 16 cm; rim th.: 1.4 cm; wall th.: 0.7 cm.

Clay: outer, inner and fabric colour: 2.5Y 8/3 (pale brown); sand inclusions; medium-high firing temperature.

Description: triangular rim jar.

AbT.12.52.12 - Fig. 8.13

Dimensions: rim diam.: 17 cm; rim th.: 0.7 cm; wall th.: 0.8 cm.

Clay: outer and inner colour: 2.5Y 8/2 (pale brown); fabric colour: 5YR 6/4 (light reddish brown); sand inclusions; medium-high firing temperature.

Description: plain rim jar.

AbT.12.52.13 - Fig. 8.13

Dimensions: rim diam.: 16 cm; rim th.: 0.7 cm; wall th.: 0.7 cm.

Clay: outer colour: 2.5Y 8/2 (pale brown); inner and fabric colour: 5YR 5/4 (reddish brown); sand and vegetal inclusions; medium firing temperature.

Description: plain rim jar.

AbT.12.52.14 - Fig. 8.12

Dimensions: rim diam.: 18 cm; rim th.: 0.6 cm; wall th.: 0.5 cm.

Clay: outer colour: 7.5YR 8/3 (pink); inner and fabric colour: 5YR 5/4 (reddish brown); sand inclusions; medium firing temperature.
Description: drinking vessel rim.

AbT.12.52.15 - Fig. 8.13

Dimensions: rim diam.: n.d.; rim th.: 1.8 cm; wall th.: 0.8 cm.
Clay: outer and inner colour: 5YR 8/2 (pinkish white); fabric colour: 5YR 6/4 (light reddish brown); sand inclusions; medium firing temperature.
Description: triangular rim of a jar.

AbT.12.52.16 - Fig. 8.13

Dimensions: rim diam.: 10 cm; rim th.: 0.5 cm; wall th.: 0.6 cm.
Clay: outer and inner colour: 5YR 8/2 (pinkish white); fabric colour: 2.5YR 6/6 (light red); sand inclusions; medium firing temperature.
Description: plain rim jar.

AbT.12.52.17 - Fig. 8.13

Dimensions: rim diam.: 9 cm; rim th.: 0.5 cm.
Clay: outer, inner and fabric colour: 2.5YR 4/6 (red); sand inclusions; medium-high firing temperature.
Description: plain rim jar.

AbT.12.52.18 - Fig. 8.13

Dimensions: rim diam.: n.d.; rim th.: 0.6 cm.
Clay: outer colour: 10YR 8/2 (very pale brown); inner and fabric colour: 2.5YR 5/4 (reddish brown); sand inclusions; medium firing temperature.
Description: plain rim jar.

AbT.12.52.19 - Fig. 8.12

Dimensions: rim diam.: 21 cm; rim th.: 1.6 cm; wall th.: 1 cm.
Clay: outer and inner colour: 2.5Y 8/2 (pale brown); fabric colour: 5YR 5/6 (yellowish red); sand inclusions; medium-high firing temperature.
Description: triangular rim bowl.

AbT.12.52.20 - Fig. 8.13

Dimensions: rim diam.: 10 cm; rim th.: 0.5 cm; wall th.: 0.7 cm.
Clay: outer, inner and fabric colour: 5Y 6/3 (pale olive); sand inclusions; medium firing temperature.
Description: plain rim jar.

AbT.12.52.21 - Fig. 8.13

Dimensions: wall th.: 0.6 cm; base diam.: 5.4 cm; base th.: 0.6 cm.

Clay: outer colour: 2.5Y 8/3 (pale brown); inner and fabric colour: 7.5YR 8/4 (pink); sand inclusions; medium firing temperature.
Description: rounded base of a small jar.

AbT.12.52.22 - Fig. 8.13

Dimensions: rim diam.: 52 cm; rim th.: 6.2 cm; wall th.: 2,2 cm.
Clay: outer, inner and fabric colour: 5Y 8/3 (pale yellow); sand and vegetal inclusions; low firing temperature.
Description: triangular rim vat.

AbT.12.52.23 - Fig. 8.12

Dimensions: base diam.: 4.5 cm; base th.: 0.9 cm.
Clay: outer, inner and fabric colour: 5YR 5/4 (reddish brown); sand inclusions; medium-low firing temperature.
Description: conical bowl base.

AbT.12.52.24 - Fig. 8.12

Dimensions: wall th.: 0.6 cm; base diam.: 5.5 cm; base th.: 1 cm.
Clay: outer, inner and fabric colour: 5YR 5/4 (reddish brown); sand inclusions; medium firing temperature.
Description: drinking vessel base.

AbT.12.52.25 - Fig. 8.12

Dimensions: base diam.: 4.4 cm; base th.: 0.7 cm.
Clay: outer, inner and fabric colour: 7.5YR 6/4 (light brown); sand inclusions; medium firing temperature.
Description: beaker base.

AbT.12.52.26 - Fig. 8.12

Dimensions: wall th.: 0.4 cm; base diam.: 4 cm; base th.: 1 cm.
Clay: outer, inner and fabric colour: 10YR 8/3 (very pale brown); sand inclusions; medium-low firing temperature.
Description: beaker base.

AbT.12.52.27 - Fig. 8.12

Dimensions: wall th.: 0.6 cm; base diam.: 5 cm; base th.: 0.9 cm.
Clay: outer, inner and fabric colour: 7.5YR 4/4 (brown); sand inclusions; medium firing temperature.
Description: beaker base.

AbT.12.52.28 - Fig. 8.12

Dimensions: rim diam.: 12.2 cm; rim th.: 0.6 cm; wall th.: 0.8 cm; base diam.: 5 cm; base th.: 1.2 cm; h.: 13.1 cm.
Clay: outer colour: 2.5Y 8/2 (pale brown); inner and fabric colour: 7.5YR 6/4 (light brown); sand inclusions; medium firing temperature.
Description: beaker base.

AbT.12.52.29 - Fig. 8.12

Dimensions: wall th.: 0.6 cm; base diam.: 5 cm; base th.: 1.3 cm.
Clay: outer colour: 2.5Y 8/2 (pale brown); inner and fabric colour: 5YR 5/4 (reddish brown); sand inclusions; medium firing temperature.
Description: beaker base.

AbT.12.52.30 - Fig. 8.12

Dimensions: wall th.: 1.4 cm; base diam.: 5.5 cm; base th.: 1.2 cm.
Clay: outer, inner and fabric colour: 5YR 4/3 (reddish brown); sand inclusions; medium-low firing temperature.
Description: drinking vessel base.

AbT.12.52.31 - Fig. 8.12

Dimensions: wall th.: 0.8 cm; base diam.: 4.5 cm; base th.: 1 cm.
Clay: outer, inner and fabric colour: 5YR 4/33 (reddish brown); sand inclusions; medium-low firing temperature.
Description: drinking vessel base.

AbT.12.52.32 - Fig. 8.13

Dimensions: rim th.: 0.6 cm; wall th.: 0.6 cm; base diam.: 15 cm; base th.: 0.8 cm.
Clay: outer colour: 10YR 8/2 (very pale brown); inner and fabric colour: 5YR 5/4 (reddish brown); sand inclusions; medium-high firing temperature.
Description: flat base.

AbT.12.52.33 - Fig. 8.13

Dimensions: wall th.: 0.8 cm; base diam.: 16 cm; base th.: 0.9 cm.
Clay: outer, inner and fabric colour: 5Y 7/3 (pale yellow); sand inclusions; medium firing temperature.
Description: flat base.

AbT.12.52.34 - Fig. 8.13

Dimensions: wall th.: 0.5 cm; base diam.: 11.5 cm; base th.: 0.6 cm.
Clay: outer, inner and fabric colour: 2.5YR 4/4 (reddish brown); sand inclusions; medium firing temperature.
Description: flat base.

AbT.12.52.35 - Fig. 8.13

Dimensions: wall th.: 0.8 cm; base diam.: 17 cm; base th.: 0.8 cm.
Clay: outer, inner and fabric colour: 10YR 8/3 (very pale brown); sand inclusions; medium firing temperature.
Description: convex base.

AbT.12.52.36 - Fig. 8.13

Dimensions: wall th.: 0.7 cm; base diam.: 11 cm; base th.: 0.7 cm.
Clay: outer, inner and fabric colour: 10YR 7/3 (very pale brown); sand and vegetal inclusions; medium firing temperature.
Description: flat base.

AbT.12.52.37 - Fig. 8.13

Dimensions: wall th.: 0.8 cm; base diam.: 18 cm; base th.: 1 cm.
Clay: outer colour: 2.5Y 8/3 (pale brown); inner and fabric colour: 5YR 5/4 (reddish brown); sand and vegetal inclusions; medium firing temperature.
Description: slightly convex base with a hole near the base (1.1 cm diam.).

AbT.12.52.38 - Fig. 8.13

Dimensions: wall th.: 0.6 cm; base diam.: 35.6 cm; base th.: 0.9 cm.
Clay: outer, inner and fabric colour: 7.5YR 6/4 (light brown); sand inclusions; medium firing temperature.
Description: ring base.

AbT.12.52.39 - Fig. 8.13

Dimensions: wall th.: 0.8 cm; base diam.: 32 cm; base th.: 0.9 cm.
Clay: outer, inner and fabric colour: 10YR 6/4 (light yellowish brown); sand inclusions; medium firing temperature.
Description: ring base.

Catalogue of US 54 Finds

*Objects***AbT.12.137 - Fig. 8.10**

Description: copper alloy point.
Dimensions: 1.1x0.6 cm.

AbT.12.138 - Fig. 8.10

Description: unidentified burnt clay object. It has the shape of a "V", like the legs of an animal figurine. However, both the dimensions and the absence of fracture seems to deny this interpretation.
Dimensions: 1.24x1.21x0.4 cm.

AbT.12.139 - Fig. 8.10

Description: little grey stone pebble.
Dimensions: 1.x1x0.9 cm; weight 1 gr.

*Pottery***AbT.12.54.1 - Fig. 8.14**

Dimensions: rim diam.: 16 cm; rim th.: 0.7 cm; wall th.: 0.7 cm.
Clay: outer and inner colour: 10YR 8/3 (very pale brown); fabric colour: 5YR 6/6 (reddish yellow); sand inclusions; medium-high firing temperature.
Description: drinking vessel rim.

AbT.12.54.2 - Fig. 8.14

Dimensions: rim diam.: n.d.; rim th.: 0.6 cm.
Clay: outer, inner and fabric colour: 2.5Y 8/3 (pale brown); sand inclusions; medium-high firing temperature.
Description: plain rim jar.

AbT.12.54.3 - Fig. 8.14

Dimensions: rim diam.: 13 cm; rim th.: 0.6 cm.
Clay: outer colour: 2.5Y 8/3 (pale brown); inner and fabric colour: 7.5YR 6/4 (light brown); sand inclusions; medium-high firing temperature.
Description: band rim jar.

AbT.12.54.4 - Fig. 8.14

Dimensions: wall th.: 0.6 cm; base diam.: 8 cm; base th.: 0.7 cm.
Clay: outer, inner and fabric colour: 7.5YR 5/4 (brown); sand inclusions; medium-high firing temperature.
Description: flat base.

AbT.12.54.5 - Fig. 8.14

Dimensions: wall th.: 0.7 cm; base diam.: 15.8 cm; base th.: 0.9 cm.
Clay: outer, inner colour: 5Y 7/3 (pale yellow); inner and fabric colour: 5Y 6/4 (pale olive); sand inclusions; medium firing temperature.
Description: flat base.

AbT.12.54.6 - Fig. 8.14

Dimensions: wall th.: 0.5 cm; base diam.: 11 cm; base th.: 0.9 cm.
Clay: outer colour: 5Y 7/3 (pale yellow); fabric colour: 5Y 6/3 (pale olive); sand inclusions; medium-high firing temperature.
Description: flat base.

AbT.12.54.7 - Fig. 8.14

Dimensions: wall th.: 0.8 cm; base diam.: 15 cm; base th.: 1 cm.
Clay: outer, inner and fabric colour: 7.5YR 4/4 (brown); sand inclusions; medium firing temperature.
Description: flat base.

AbT.12.54.8 - Fig. 8.14

Dimensions: wall th.: 0.7 cm; base diam.: 15 cm; base th.: 0.5 cm.
Clay: outer, inner and fabric colour: 7.5YR 6/3 (light brown); sand inclusions; medium firing temperature.
Description: flat base.

AbT.12.54.9 - Fig. 8.14

Dimensions: rim diam.: 56 cm; rim th.: 3.5 cm; wall th.: 1.9 cm.
Clay: outer, inner and fabric colour: 10YR 8/3 (very pale brown); sand and vegetal inclusions; medium firing temperature.
Description: band rim of a vat/jar.

AbT.12.54.10 - Fig. 8.14

Dimensions: rim diam.: n.d.; rim th.: 4.8 cm; wall th.: 2.8 cm.
Clay: outer, inner and fabric colour: 5Y 5/3 (olive); sand and vegetal inclusions; medium-low firing temperature.
Description: triangular rim vat.

AbT.12.54.11 - Fig. 8.14

Dimensions: wall th.: 1.75 cm; base diam.: 40 cm; base th.: 1.9 cm.
Clay: outer, inner and fabric colour: 5Y 5/3 (olive); sand and vegetal inclusions; medium firing temperature.
Description: almost flat base covered with bitumen.

AbT.12.54.12 - Fig. 8.14

Dimensions: rim diam.: 4 cm; rim th.: 0.5 cm; wall th.: 0.5 cm; base diam.: 4 cm; base th.: 0.8 cm; h.: 8.4 cm.
Clay: outer, inner and fabric colour: 5YR 5/6 (yellowish red); sand inclusions; medium firing temperature.
Description: miniaturistic plain rim jar.

Catalogue of US 77 Finds

*Pottery***AbT.12.77.1 - Fig. 8.15**

Dimensions: rim diam.: 28 cm; rim th.: 1.7 cm; wall th.: 0.9 cm.

Clay: outer, inner and fabric colour:
5YR 4/4 (reddish brown); sand
inclusions; medium firing temperature.
Description: out-turned rim bowl.

AbT.12.77.2 - Fig. 8.15

Dimensions: rim diam.: 12 cm; rim th.:
0.6 cm; wall th.: 0.8 cm.

Clay: outer, inner and fabric colour:
5YR 6/6 (reddish yellow); sand
inclusions; medium firing temperature.
Description: drinking vessel rim.

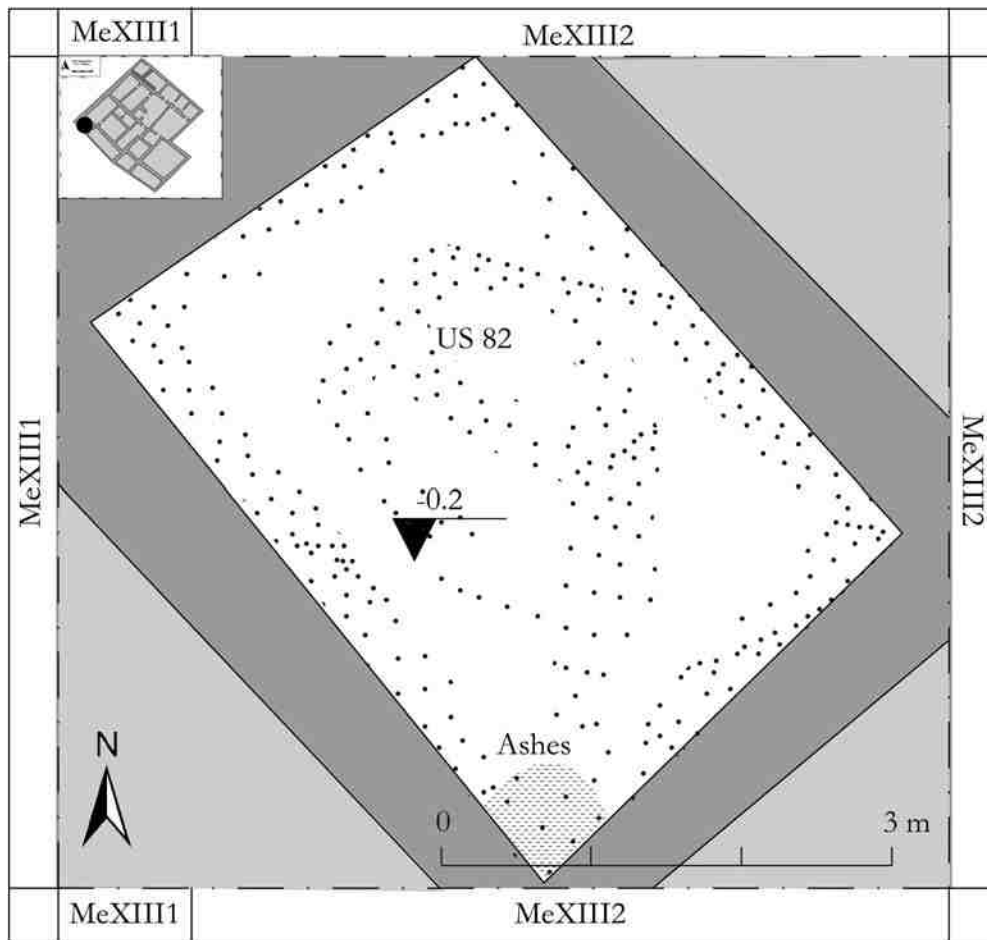

Fig. 8.16 Room 3 plan.

8.3 ROOM 3 [LR]

It was impossible to identify a clear distinction between the filling and a ground-surface in Room 3 (Fig. 8.16). On the basis of the elevation (-0.19) US 82 is the only one that can be attributed to the phase of the Building. This US, an horizontal light yellowish brown silty-clay stratum with some ashy lens in the southern corner was however almost completely empty.

Catalogue of US 82 Finds

Objects

AbT.12.157 - Fig. 8.17

Description: grey stone pebble.

Dimensions: 4.5x3x0.8 cm; weight 15 gr.



Fig. 8.17 US 82 objects.

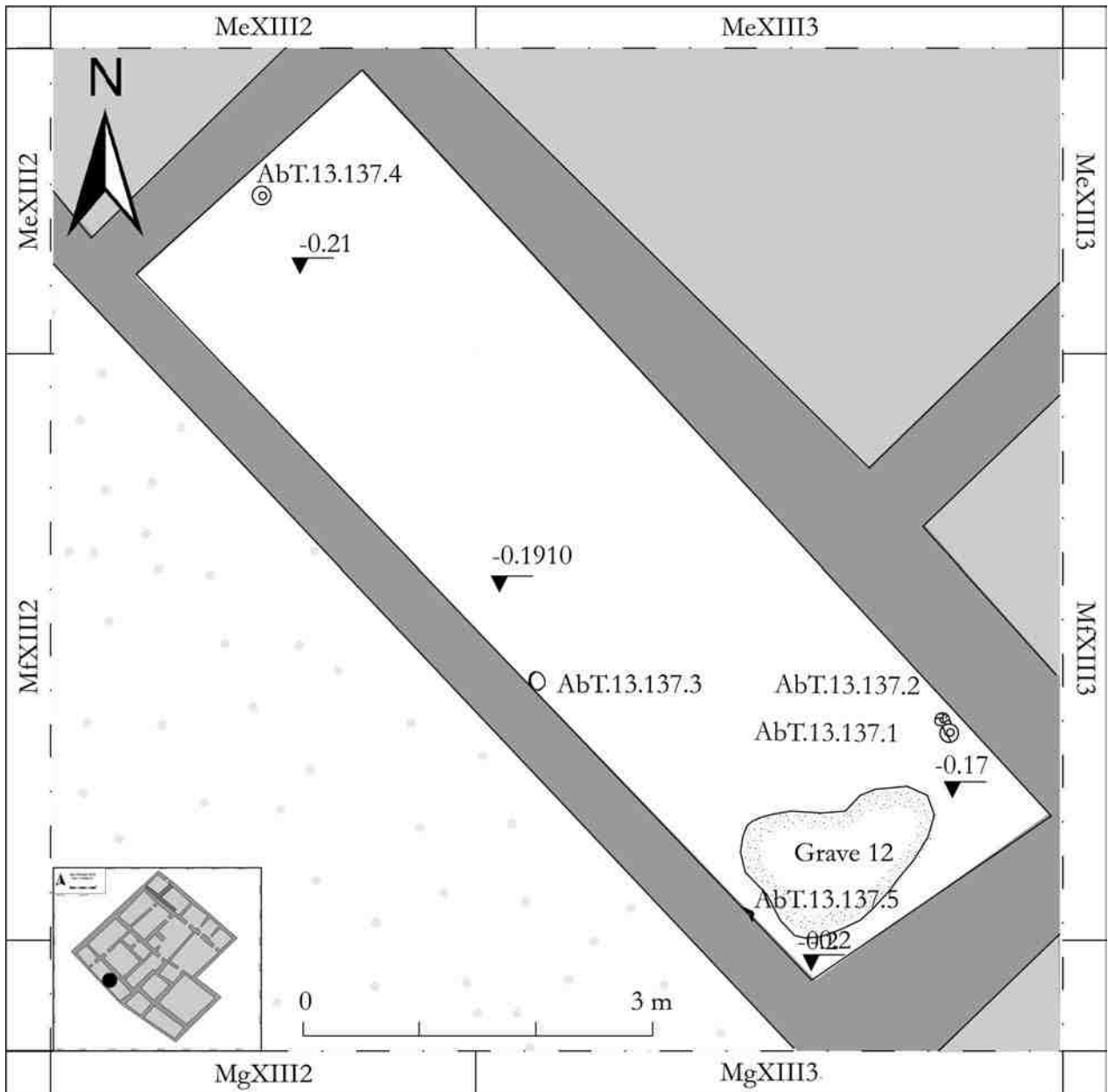

Fig. 8.18 Room 4 plan.

8.4 ROOM 4 [LR]

The excavation of Room 4 (Fig. 8.18) was hampered by the not clear distinction among the identified strata. The filling of the Room, cut by Graves 1, 6 and 11,⁷ consisted in a clay stratum (US 126) with collapsed mud-brick fragments, probably pertaining to the structure. In the filling a piece of a bitumen ingot covered by reed-mat was found, sloping down in the soil. The pottery fragments discovered in the filling mostly belong, as usual, to drinking vessels, though fragments of jars were also recovered. No pavement was clearly

identified but the ground-surface (US 202) was hypothesized *a posteriori* at the elevation of -0.2 m, in correspondence with some “foundation bowls” discovered in the Room. The conical bowls were placed along the north-west (AbT.13.137.4), south-west (AbT.13.137.3 and AbT.13.137.5) and north-east walls (AbT.13.137.1 and AbT.13.137.2). The presence of the conical bowls in the middle of the north-west wall might suggest that there was no door here (while there is a passage towards Room 3 in the earlier phase of the Building). Under the pavement a grave (Grave 12, skeleton US 145, equipment US 144, cut US 149) of a female adult of 20-30 years of age was discovered (Figs 8.19-

⁷ See §§ 7.1.2, 5-6.

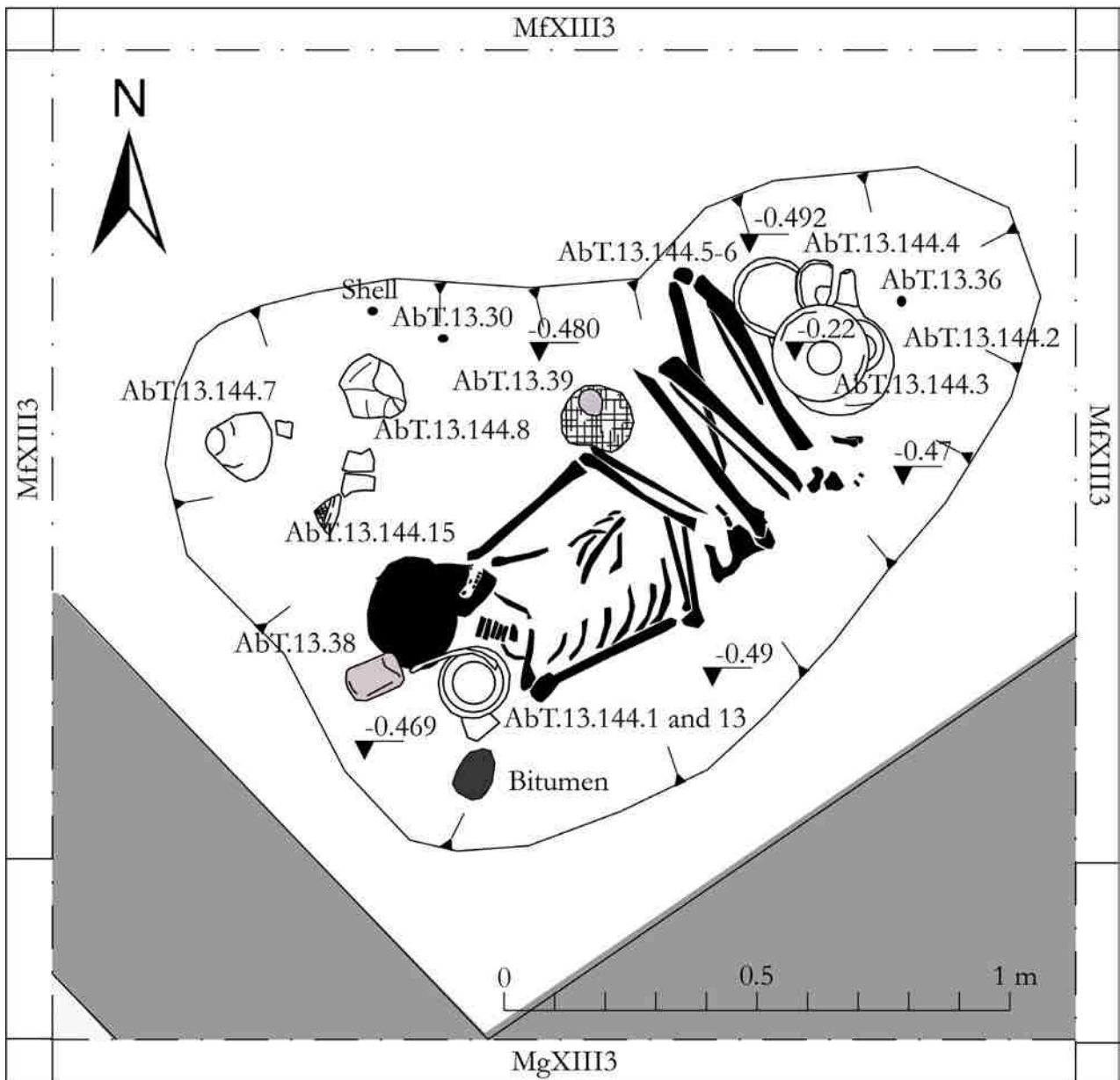

Fig. 8.19 Room 4. Grave 12 plan.

20). The woman was in a semi-flexed position, with the head towards west and looking north, the legs bent, and the arms crossed on the pelvis. The equipment was made up of several stone pestles, a fragment of an alabaster vessel and a bivalve shell with cosmetic paste found inside a small reed basket near the left side of the woman. A copper alloy ring was discovered on the pelvis during the laboratory excavation.

The pottery assemblage deposited near the body consisted of 3 beakers, 8 conical bowls, fragments of a stemmed-dish, a small jar with a globular body, and a spouted jar.⁸ The grave was cut immediately under the pavement at the elevation of -0.29 m and reached the depth of -0.49 m ca.

⁸ D'Agostino *et al.* 2015: 214. The other finds collected in the backfill but probably in secondary deposition.



Fig. 8.20 Room 4. Grave 12.



Fig. 8.21 US 126 objects.

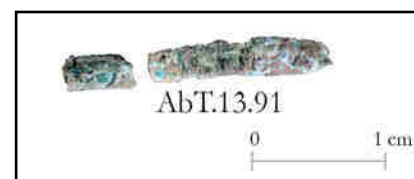

Fig. 8.22 US 145 objects.

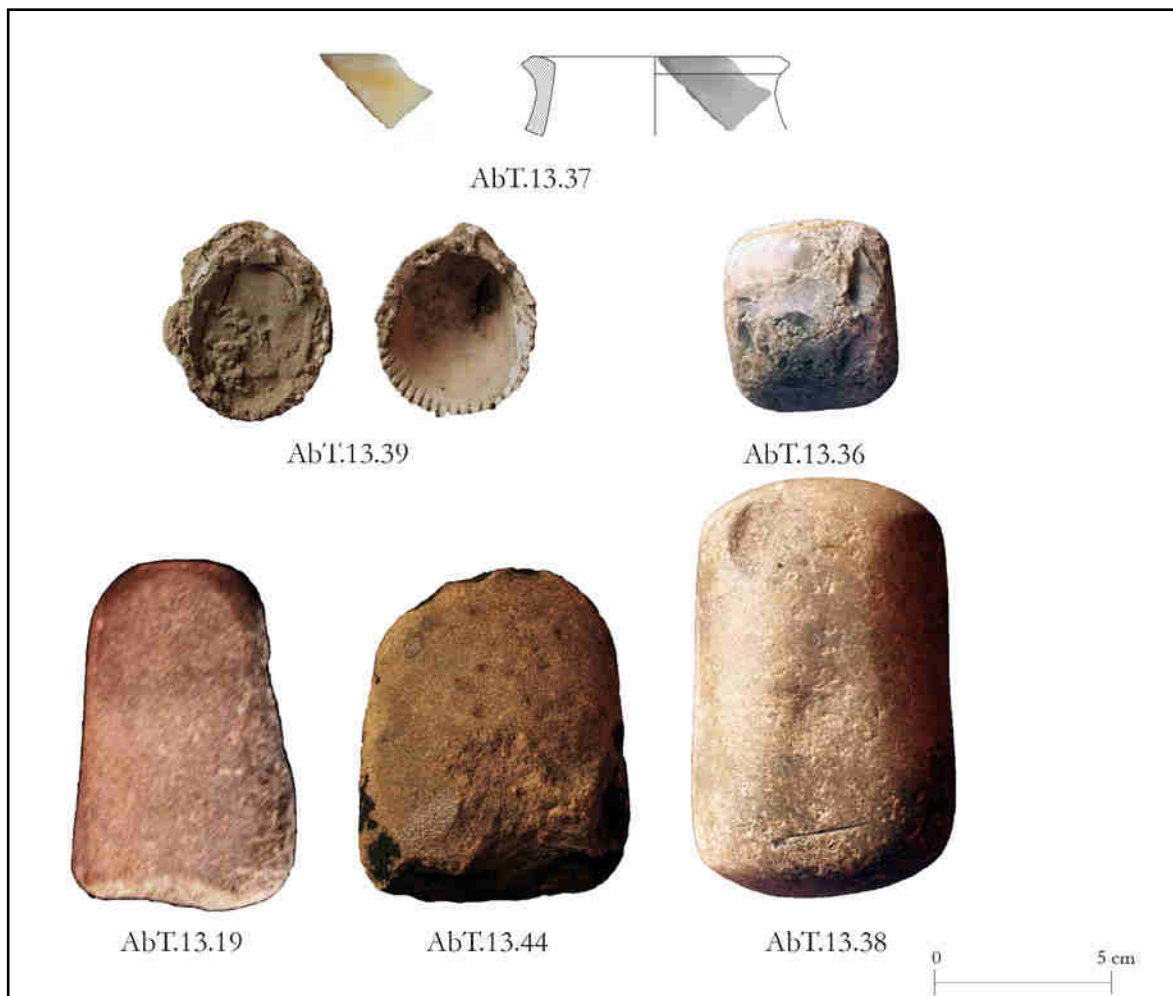

Fig. 8.23 US 144 objects.

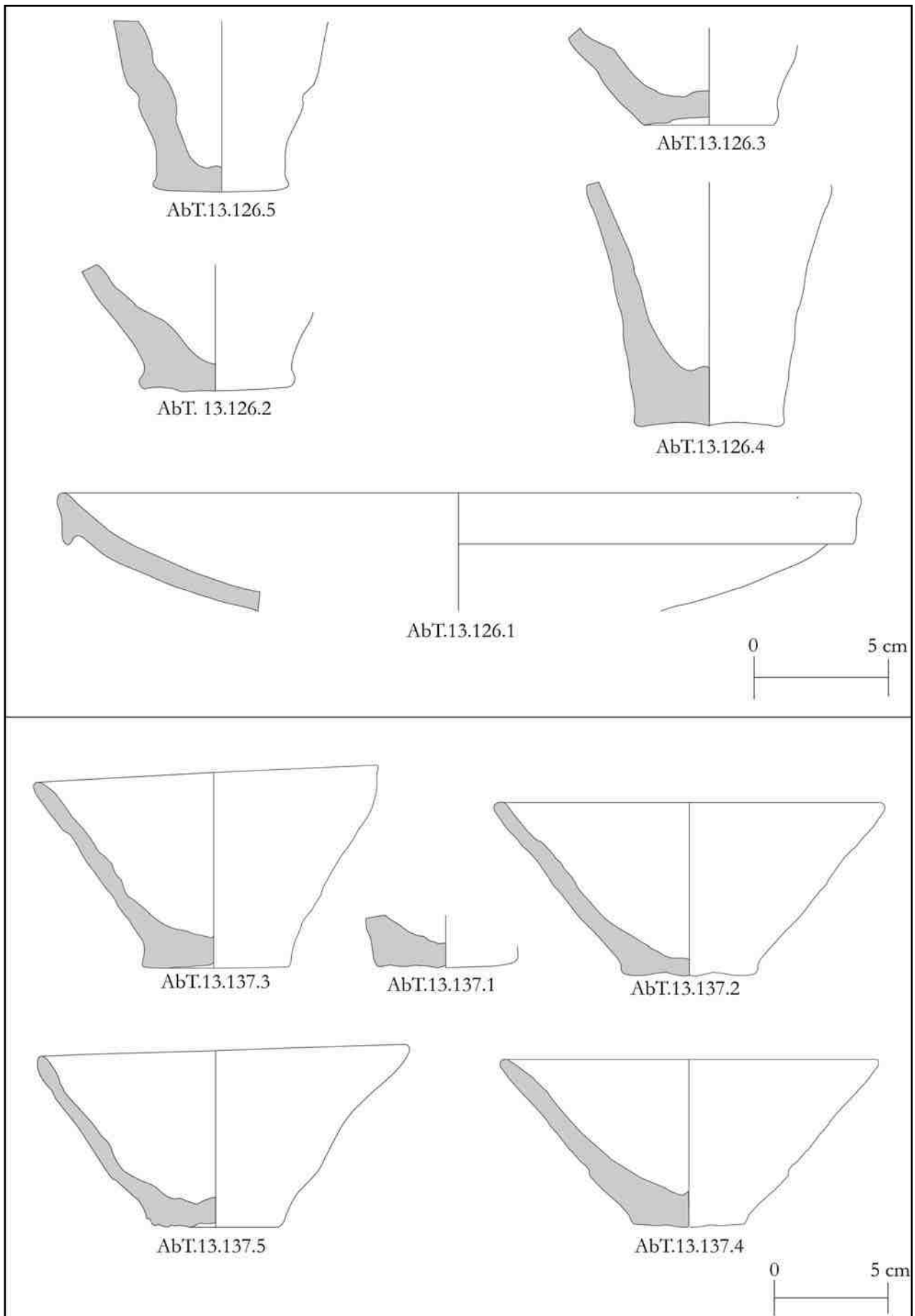

Fig. 8.24 US 126 and 137 pottery.

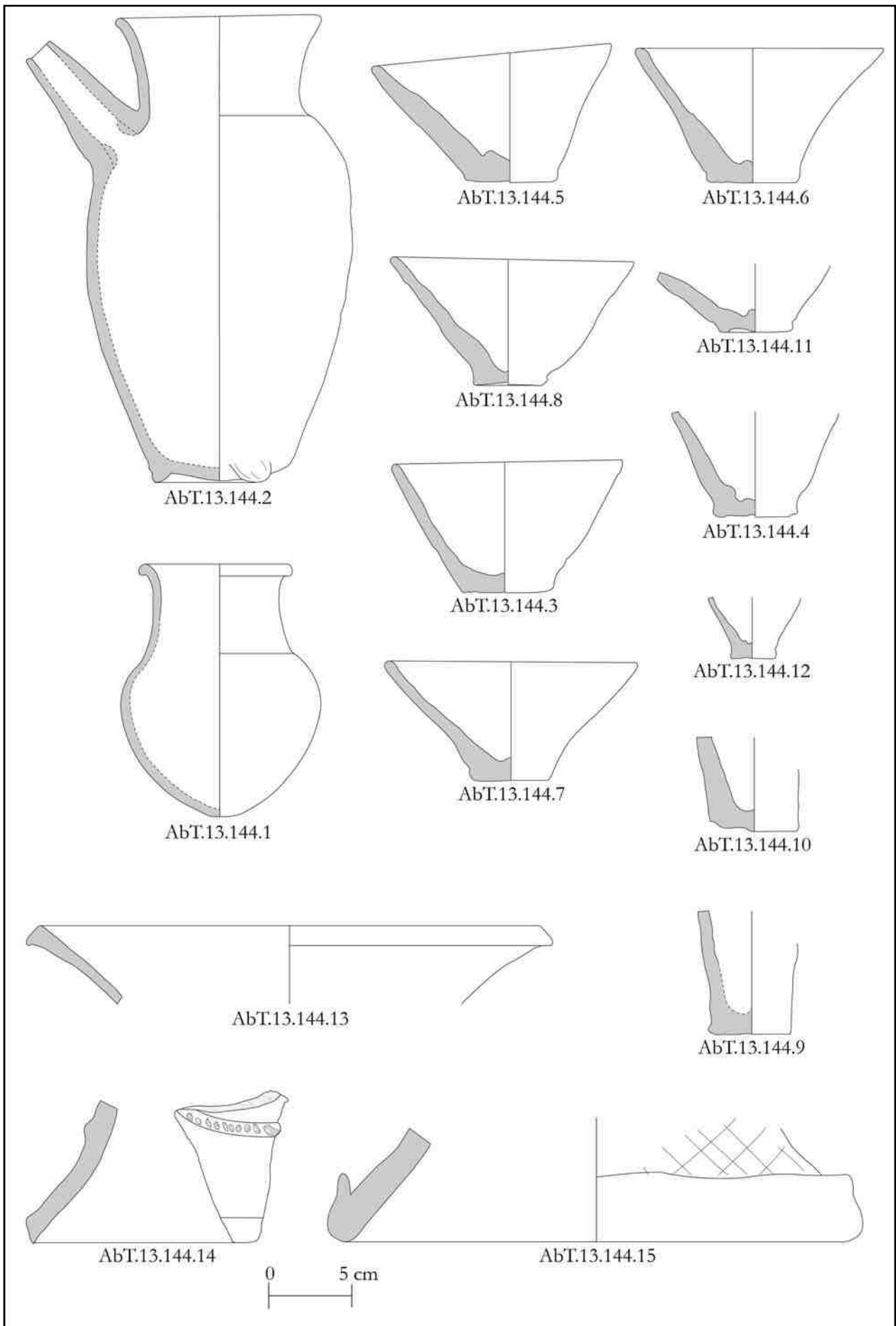

Fig. 8.25 US 144 pottery.

Catalogue of US 126 Finds

*Objects***AbT.13.12 - Fig. 8.21**

Description: black stone smoothing tool. Long and thin polisher. One of the tips shows heavy signs of use-wear and striations. [SC]

Dimensions: 8x1.9 cm.

AbT.13.13 - Fig. 8.21

Description: chert blade.

Dimensions: 7.6 x0.55 cm.

AbT.13.8 - Fig. 8.21

Description: white stone pestle. Both ends of the tool have pounding traces. Half of the tool is heavily eroded, one part of the tool shows a scaly fracture, whereas the other is smooth and shows little or no traces (some of the pounding traces are partially cancelled). The tool was possibly reused after the fracture and has some bitumen residues on one principal functional area. [SC]

Dimensions: 5.6x7.7x4.65 cm.

AbT.13.9 - Fig. 8.21

Description: chert blade.

Dimensions: 1.75x8.1x0.55 cm.

*Pottery***AbT.13.126.1 - Fig. 8.24**

Dimensions: rim diam.: 29 cm; rim th.: 1.5 cm; wall th.: 1.6 cm.

Clay: outer and inner colour: 10YR 7/3 (very pale brown); fabric colour: 7.5YR 6/4 (light brown); sand inclusions; medium-high firing temperature.

Description: triangular rim bowl.

AbT.13.126.2 - Fig. 8.22

Dimensions: wall th.: 0.8 cm; base diam.: 5.6 cm; base th.: 1.3 cm.

Clay: outer colour: 10YR 8/3 (very pale brown); inner and fabric colour: 7.5YR 6/4 (light brown) sand inclusions; medium-low firing temperature.

Description: conical bowl base.

AbT.13.126.3 - Fig. 8.24

Dimensions: wall th.: 0.8 cm; base diam.: 5 cm; base th.: 1 cm.

Clay: outer, inner and fabric colour: 7.5YR 5/4 (brown); sand and small vegetal inclusions; medium-low firing temperature.

Description: conical bowl base.

AbT.13.126.4 - Fig. 8.24

Dimensions: base diam.: 5.5 cm; base th.: 1.3 cm.

Clay: outer, inner and fabric colour: 2.5Y 8/2 (pale brown); inner and fabric colour: 7.5YR 5/4 (brown); sand inclusions; medium firing temperature.

Description: beaker base.

AbT.13.126.5 - Fig. 8.24

Dimensions: wall th.: 1.2 cm; base diam.: 5.4 cm; base th.: 0.9 cm.

Clay: outer and inner colour: 2.5Y 8/2 (pale brown); fabric colour: 5YR 5/4 (reddish brown); sand inclusions; medium-low firing temperature.

Description: beaker base.

Catalogue of US 137 Finds

*Pottery***AbT.13.137.1 - Fig. 8.24**

Dimensions: rim diam.: 16 cm; rim th.: 0.7 cm; wall th.: 0.9 cm; base diam.: 5.8 cm; base th.: 1 cm.

Clay: outer, inner and fabric colour: 10YR 6/4 (light yellowish brown); sand inclusions; medium-low firing temperature.

Description: conical bowl found upside-down near AbT.13.137.2. Only the base was drawn due to the extremely fragmentary state.

AbT.13.137.2 - Fig. 8.24

Dimensions: rim diam.: 14 cm; rim th.: 0.6 cm; wall th.: 0.6 cm; base diam.: 7 cm ca.; base th.: 0.8 cm; h.: 7.1 cm.

Clay: outer, inner and fabric colour: 7.5YR 6/4 (light brown); sand inclusions; medium-high firing temperature.

Description: conical bowl found inclined on one side, near AbT.13.137.1.

AbT.13.137.3 - Fig. 8.24

Dimensions: rim diam.: 14 cm; rim th.: 0.7 cm; wall th.: 0.9 cm; base diam.: 6 cm; base th.: 1.2 cm; h.: 8.4 cm.

Clay: outer, inner and fabric colour: 7.5YR 6/6 (reddish yellow); sand inclusions; medium-low firing temperature.

Description: conical bowl. Found along the south-west wall of Room 4.

AbT.13.137.4 - Fig. 8.24

Dimensions: rim diam.: 14.5 cm ca.; rim th.: 0.6 cm; wall th.: 0.6-1.3 cm; base diam.: 4.8-5 cm; base th.: 1.5 cm; h.: 7.4 cm.

Clay: outer, inner and fabric colour: 7.5YR 6/6 (reddish yellow); sand inclusions; medium-low firing temperature.

Description: conical bowl. Found along the north-west wall of Room 4.

AbT.13.137.5 - Fig. 8.24

Dimensions: rim diam.: 15 cm; rim th.: 0.6 cm; wall th.: 0.9 cm; base diam.: 5.5; base th.: 1.1 cm; h.: 7.6 cm.

Clay: outer, inner and fabric colour: 7.5YR 8/3 (pink); sand inclusions; medium-low firing temperature.

Description: conical bowl found along the south-west wall of Room 4.

Catalogue of US 144 (Grave 12) Finds

*Objects***AbT.13.19 - Fig. 8.23**

Description: stone pestle with traces of intentional flaking, as if the tool was in a remodelling phase; light but concentrated pounding traces, probably expedient use; one long side of the tool has a flattened area, probably due to expedient use as polisher. [SC]

Dimensions: 5.5x8.3 cm.

AbT.13.36 - Fig. 8.23

Description: chert cube. All faces were worked to resemble a cube, however the patina makes analysis of flaking difficult. No functional traces were observed: maybe one side was slightly polished, or seems so due to contact. [SC]

Dimensions: 4.6x4.6x4 cm; weight 99 gr.

AbT.13.37 - Fig. 8.23

Description: alabaster vessel rim.

Dimensions: 7.4x0.9x0.3 cm.

AbT.13.38 - Fig. 8.23

Description: multifunctional stone tool. The main functional areas of the pestle present different trace typologies: pounding and heavy rounding, probably due to handling. The lateral sides of the pestle have

different traces too: two sides show traces of pounding, one expedient, whereas the other has traces of continuous pounding. One thin band, darker in colour, was probably used as expedient polisher, having a shiny/glossy appearance. Another larger band was probably used for polishing activity but with less intensity. [SC]

Dimensions: 10x6.2 cm.

AbT.13.39 - Fig. 8.23

Description: shell with cosmetic paste.
Dimensions: 4.5x5x4 cm.

AbT.13.44 - Fig. 8.23

Description: hammer-stone of which all sides were used for percussion actions. The ample surfaces were also used but as expedient tools, also for percussion or pounding actions. One ample surface was probably used as an abradier. Many bitumen residues present on all sides. [SC]
Dimensions: 6.6x8.3x3.5 cm.

Pottery

AbT.13.144.1 - Fig. 8.25

Dimensions: rim diam.: 9 cm ca.; rim th.: 0.7 cm; wall th.: 0.7 cm; base th.: 0.4 cm ca.; h.: 15.3 cm.

Clay: outer colour (self-slip): 2.5Y 9/2 (very pale yellow); inner and fabric colour: 10YR 7/4 (very pale brown); sand inclusions; medium firing temperature.

Description: small triangular rim jar with high neck, rounded shoulders, globular body and rounded/slightly pointed base.

AbT.13.144.2 - Fig. 8.25

Dimensions: rim diam.: 10.7 cm; rim th.: 0.6 cm; wall th.: 0.7 cm; base diam.: 8 cm; h.: 28.8 cm.

Clay: outer, inner and fabric colour: 5Y 7/3 (pale yellow); sand inclusions; medium firing temperature.

Description: spouted jar with flared and plain rim, rounded shoulders, ovoid body and three pinched feet. The jar's mouth was closed with the conical bowl AbT.13.144.3.

AbT.13.144.3 - Fig. 8.25

Dimensions: rim diam.: 14 cm; rim th.: 0.6 cm; wall th.: 0.9 cm; base diam.: 5.3 cm; base th.: 1.2 cm; h.: 7.3 cm.

Clay: outer colour: 10YR 6/4 (light yellowish brown); inner colour: 7.5YR 6/4 (light brown); fabric colour: 7.5YR 5/6 (strong brown); sand inclusions; medium-high firing temperature.

Description: conical bowl and string-cut base. Found on the mouth of the spouted jar AbT.13.144.2.

AbT.13.144.4 - Fig. 8.25

Dimensions: wall th.: 0.9 cm; base diam.: 5.1 cm; base th.: 0.9 cm.

Clay: outer, inner and fabric colour: 5YR 6/6 (reddish yellow); sand inclusions; medium-low firing temperature.

Description: conical bowl base. Found on the top of AbT.13.144.4 (partially on the jar shoulders).

AbT.13.144.5 - Fig. 8.25

Dimensions: rim diam.: 16 cm; rim th.: 0.6 cm; wall th.: 0.9 cm; base diam.: 5.7 cm; base th.: 1.2 cm; h.: 7.3 cm.

Clay: outer and inner colour: 10YR 8/3 (very pale brown); fabric colour: 7.5YR 7/4 (pink); sand inclusions; medium-high firing temperature.

Description: conical bowl.

AbT.13.144.6 - Fig. 8.25

Dimensions: rim diam.: 14 cm; rim th.: 0.6 cm; wall th.: 0.7 cm; base diam.: 5 cm; base th.: 5.5 cm; h.: 8.2 cm.

Clay: outer colour: 10YR 7/4 (very pale brown); inner colour: 7.5YR 8.5/2 (pinkish white); fabric colour: 7.5YR 4/4 (brown); sand inclusions; medium-low firing temperature.

Description: conical bowl.

AbT.13.144.7 - Fig. 8.25

Dimensions: rim diam.: 14 cm; rim th.: 0.6 cm; wall th.: 0.7 cm; base diam.: 4.5 cm; base th.: 1.2 cm; h.: 6.6 cm.

Clay: outer colour: 5YR 5/4 (reddish brown); inner: 10YR 7/3 (very pale brown); fabric colour: 7.5YR 6/4 (light brown); sand inclusions; medium-low firing temperature.

Description: conical bowl.

AbT.13.144.8 - Fig. 8.25

Dimensions: rim diam.: 15 cm; rim th.: 0.6 cm; wall th.: 0.5 cm; base diam.: 4 cm; base th.: 0.5 cm; h.: 8.2 cm.

Clay: outer and inner colour: 2.5Y 8/2 (pale brown); fabric colour: 7.5YR 7/4 (reddish yellow); sand inclusions; medium-low firing temperature.

Description: conical bowl.

AbT.13.144.9 - Fig. 8.25

Dimensions: wall th.: 0.7 cm; base diam.: 5.2 cm; base th.: 1.6 cm.

Clay: outer, inner and fabric colour: 5YR 5/4 (reddish brown); sand inclusions; medium-low firing temperature.

Description: beaker base.

AbT.13.144.10 - Fig. 8.25

Dimensions: wall th.: 0.9 cm; base diam.: 5.5 cm; base th.: 1.3 cm.

Clay: outer and inner colour: 5YR 4/6 (yellowish red); fabric colour: 5YR 6/6 (reddish yellow); sand inclusions; medium-high firing temperature.

Description: beaker base. Found over the left arm of the body.

AbT.13.144.11 - Fig. 8.25

Dimensions: wall th.: 0.7 cm; base diam.: 5.3 cm; base th.: 1.6 cm.

Clay: outer and inner: 5YR 6/4 (light reddish brown); fabric colour: 5YR 6/4 (yellowish red); sand inclusions; medium-low firing temperature.

Description: conical bowl base.

AbT.13.144.12 - Fig. 8.25

Dimensions: wall th.: 0.4 cm; base diam.: 2.5 cm; base th.: 1 cm.

Clay: outer, inner and fabric colour: 7.5YR 7/6 (reddish yellow); sand inclusions; medium-low firing temperature.

Description: base of a small conical bowl.

AbT.13.144.13 - Fig. 8.24

Dimensions: rim diam.: 30 cm; rim th.: 0.9 cm.

Clay: outer and inner colour: 2.5Y 8/2 (pale brown); fabric colour: 7.5YR 6/4 (light brown); sand inclusions; medium-high firing temperature.

Description: triangular rim bowl.

AbT.13.144.14 - Fig. 8.24

Dimensions: rim diam.: n.d.; rim th.: 1.4 cm; wall th.: 1.1 cm.

Clay: outer and inner colour: 10YR 6/4 (light yellowish brown); fabric colour: 7.5YR 6/4 (light brown); sand inclusions; medium firing temperature.

Description: stemmed-dish base with notched ridge.

AbT.13.144.15 - Fig. 8.24

Dimensions: rim diam.: 30 cm; rim th.: 1.6 cm; wall th.: 0.9 cm.

Clay: outer and inner: 5YR 6/6 (reddish yellow); fabric colour: 5YR 5/6 (yellowish red); sand inclusions; medium firing temperature.

Description: stemmed-dish base fragment with incised hatched decoration.

Catalogue of US 145 (Grave 12)

Finds

Objects

AbT.13.91 - Fig. 8.22

Description: copper alloy ring found on the pelvis of the skeleton.

Dimensions: 0.2x0.1x3 cm.

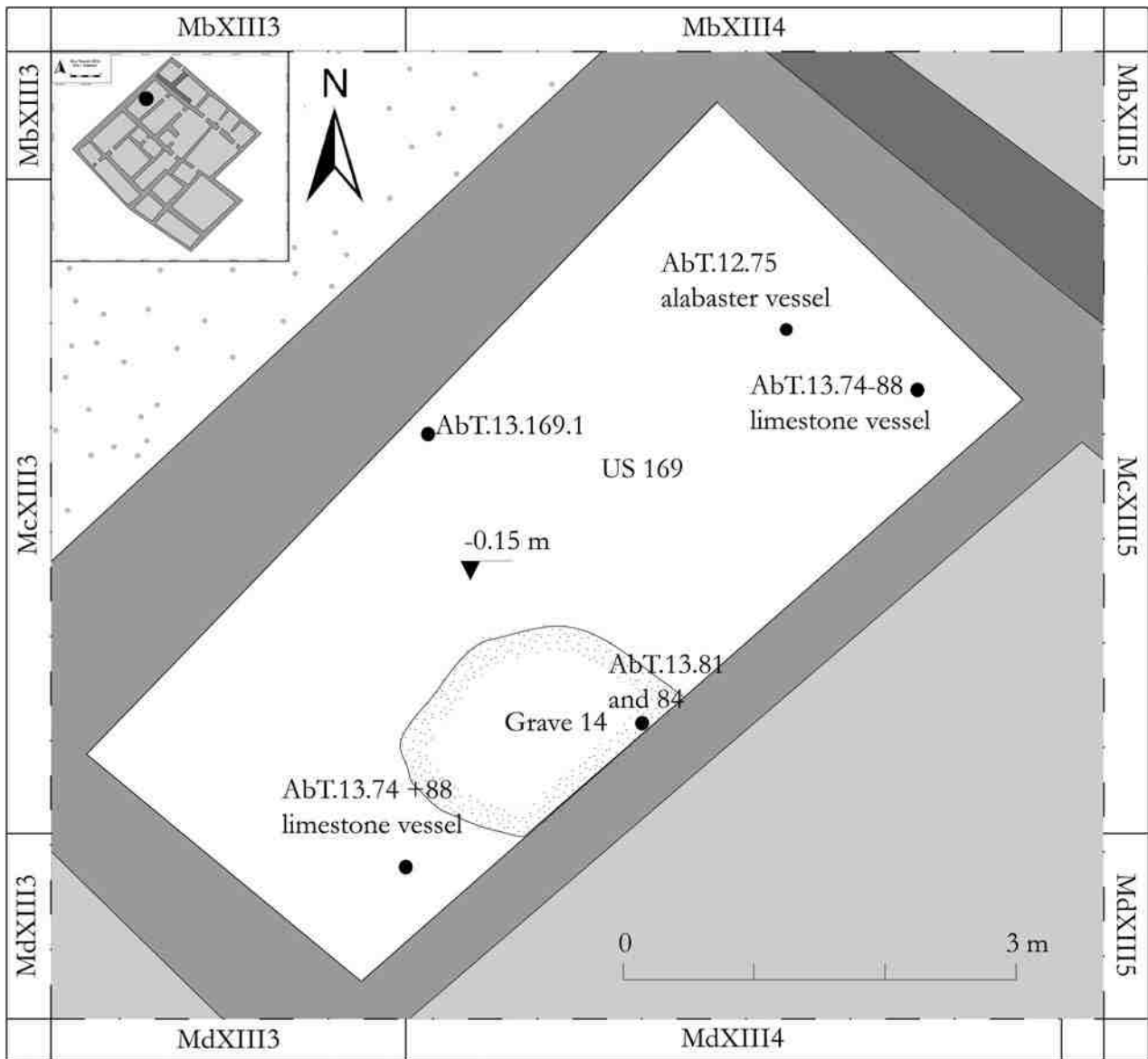

Fig. 8.26 Room 5 plan.

8.5 ROOM 5 [LR]

Room 5 (Fig. 8.28) was probably exposed for a long period to water erosion, as a consequence of the passage over this part of the Building of a rainfall gully (Fig. 6.4). The filling of the Room (US 169) consisted of a horizontal seasonal deposit composed by several thin lenses of grey and yellowish soil. The effects of the long exposure to the atmospheric agents on the material *in situ* over the pavement are evident from the discovery of a limestone vessel broken in two halves displaced in different parts of the Room.⁹ An alabaster vessel and some fragments of copper-alloy objects were also recovered. Half of a backed plano-convex brick, two sickle elements and a fragment of rock-

crystal were also found in the filling. Regarding the pottery, several fragments of drinking vessels were collected (at least 6 beakers and 5 conical bowls) together with fragments of jars, though not clearly belonging to complete vessels. There was no evident distinction between the stratum filling the Room and the ground surface (US 188), that was reconstructed at the elevation of -0.15 m, after the top of Grave 14 cut was identified.¹⁰

⁹ D'Agostino - Romano 2015: 215-216.

¹⁰ On the contrary, the pavement of the earlier phase of Room 5 was clearly identified: see Cereda - Romano 2018.

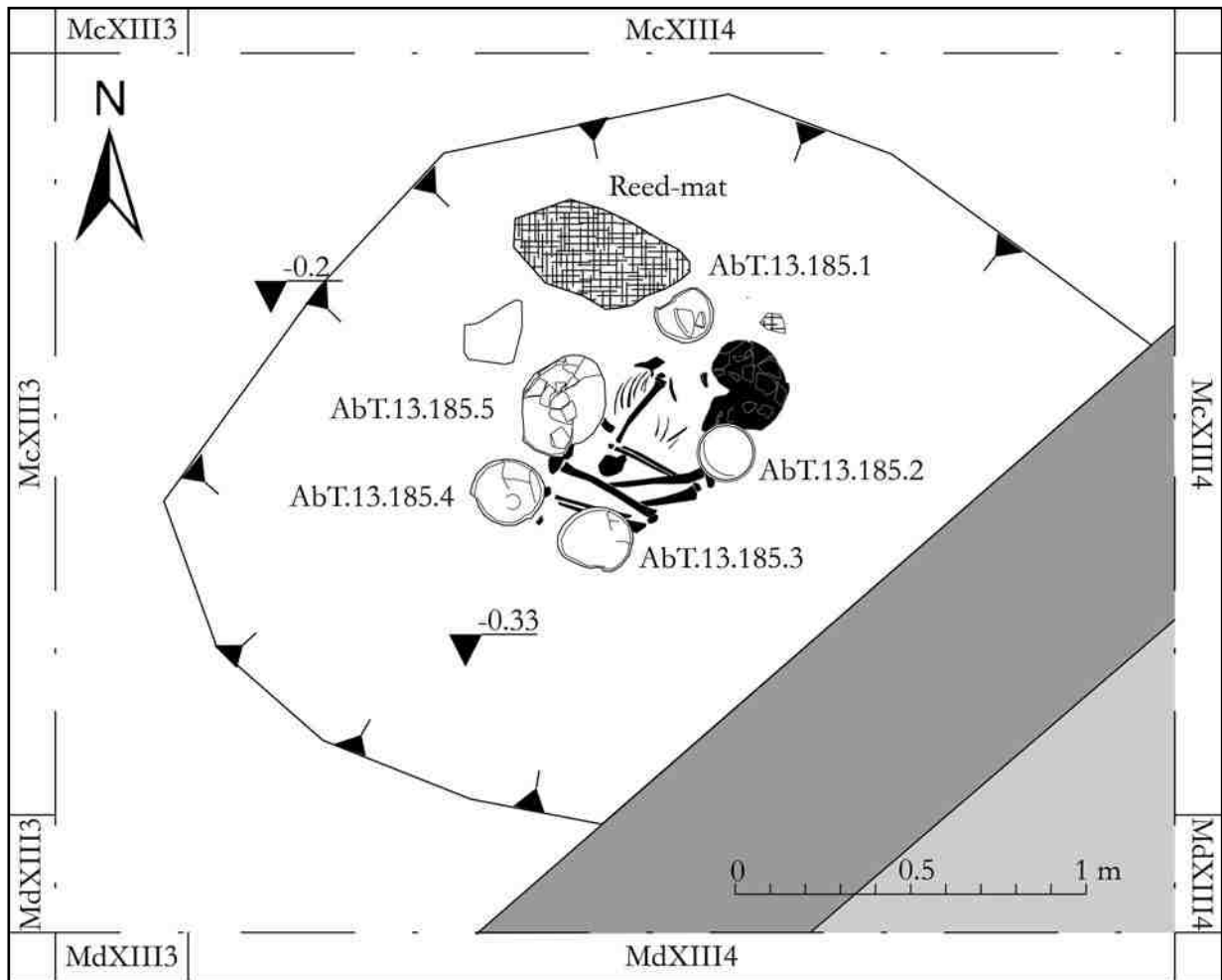

Fig. 8.27 Room 5. Grave 14 plan.

Grave 14 was the inhumation of a child of ca. 6 years (Figs 8.26-28). The body was in foetal position, laying on his left side, with the head towards north-east and looking south. A stratum of pure and compact clay (US 185) sealed the grave. The equipment consisted of a jar, two beakers and two conical bowls, while remains of a reed-mat were preserved near the body (US 186). The cut of the grave reached the depth of 0.3 m ca. (US 187).



Fig. 8.28 Room 5. Grave 14.



Fig. 8.29 Room 5. Grave 14. Pottery equipment.

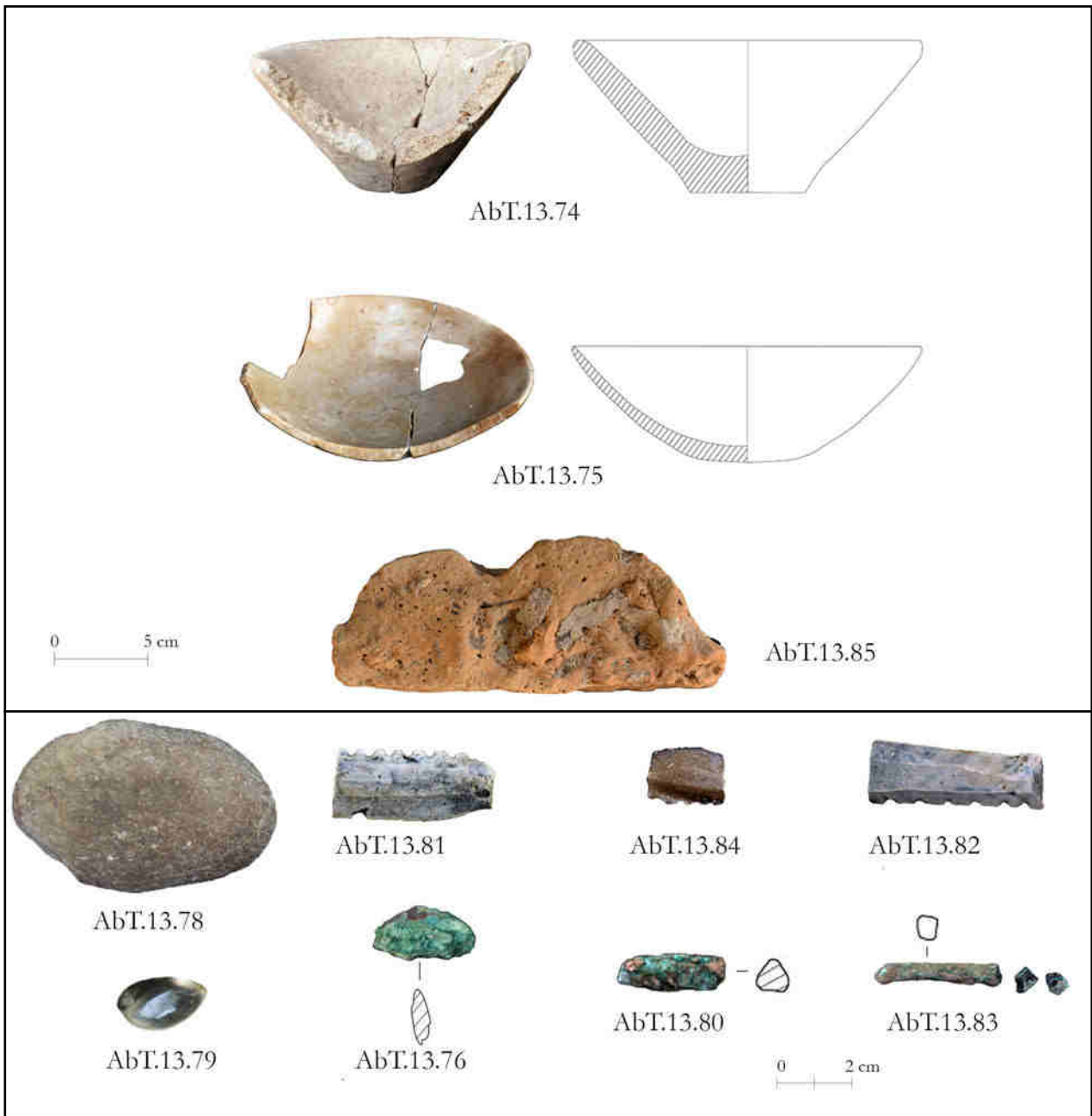

Fig. 8.30 US 169 objects.



Fig. 8.31 US 188 objects.

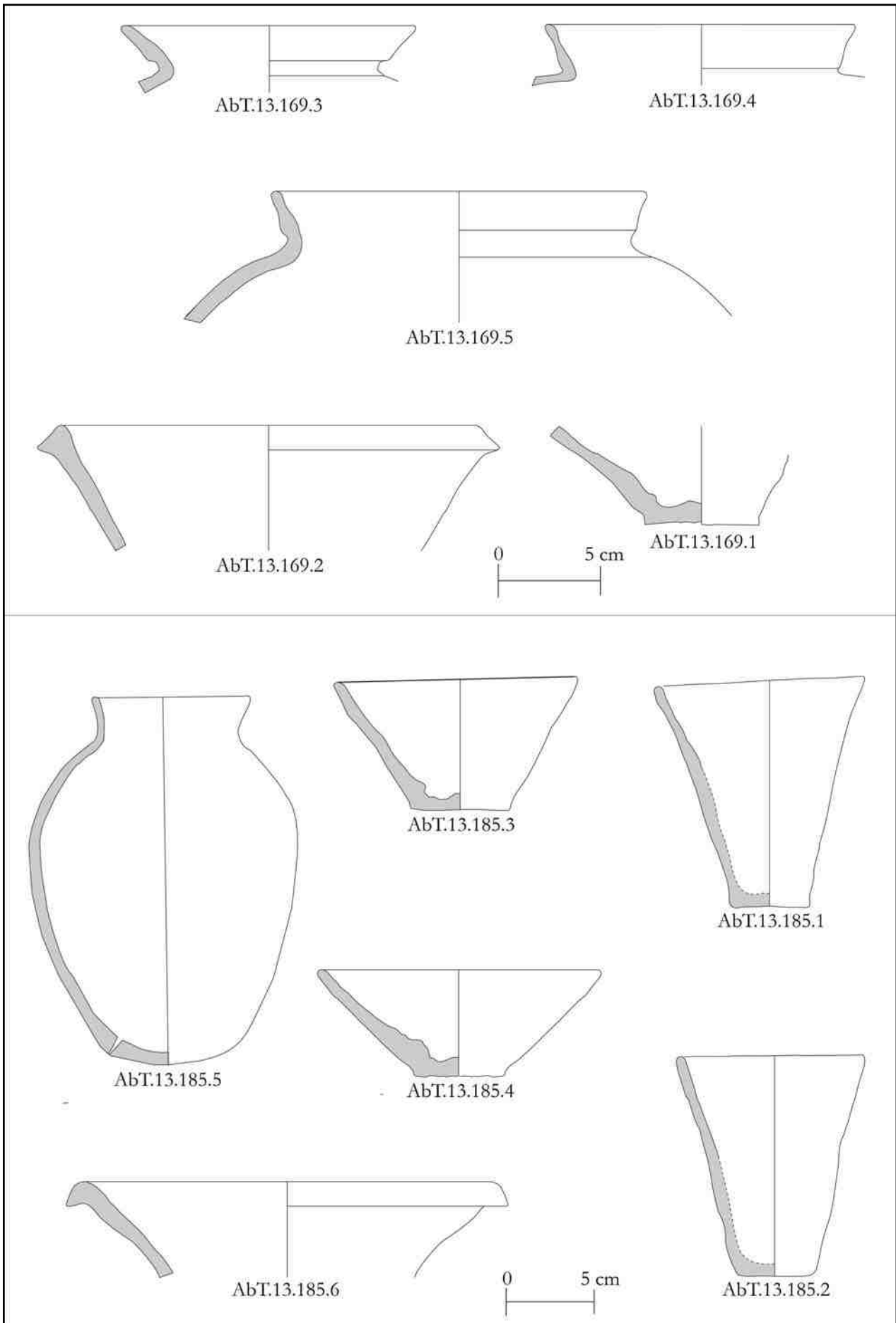

Fig. 8.32 US 169 and US 185 pottery.

Catalogue of the US 169 Finds

*Objects***AbT.13.74 - Fig. 8.30**

Description: limestone bowl.
Dimensions: 17x6.5x9.1 cm.

AbT.13.75 - Fig. 8.30

Description: alabaster bowl.
Dimensions: 18x6x6 cm.

AbT.13.76 - Fig. 8.30

Description: copper alloy fragment.
Dimensions: 1.3x2.4x0.5 cm.

AbT.13.78 - Fig. 8.30

Description: stone pebble.
Dimensions: 4x6.3x2 cm.

AbT.13.79 - Fig. 8.30

Description: rock crystal fragment.
Dimensions: 1.3x2.3x1 cm.

AbT.13.80 - Fig. 8.30

Description: copper alloy fragment.
Dimensions: 0.8x2.6x0.6 cm.

AbT.13.81 - Fig. 8.30

Description: chert blade with one side retouched and haft element on the other.
Dimensions: 1.2x3.8x0.3 cm.

AbT.13.82 - Fig. 8.30

Description: chert sickle element.
Dimensions: 1.5x4.1x0.4 cm.

AbT.13.83 - Fig. 8.30

Description: copper alloy object.
Dimensions: 0.5x3.6x0.5 cm.

AbT.13.84 - Fig. 8.30

Description: chert sickle element.
Dimensions: 1.4x1.9x0.4 cm.

AbT.13.85 - Fig. 8.30

Description: half planoconvex brick.
Dimensions: 10.6x16x6 cm.

*Pottery***AbT.13.169.1 - Fig. 8.32**

Dimensions: wall th.: 0.6 cm; base diam.: 5.5 cm; base th.: 1.3 cm.
Clay: outer and inner colour: 2.5Y 7/4 (pale brown); fabric colour: 7.5YR 5/6 (strong brown); sand inclusions; medium-low firing temperature.
Description: conical bowl base.

AbT.13.169.2 - Fig. 8.32

Dimensions: rim diam.: 20 cm; rim th.: 1.7 cm; wall th.: 0.8 cm.
Clay: outer colour (self-slip): 10YR 8/3 (very pale brown); inner colour (self-slip): 2.5Y 8/3 (pale brown); fabric colour: 5YR 5/6 (yellowish red); sand inclusions; medium firing temperature.
Description: triangular rim bowl.

AbT.13.169.3 - Fig. 8.32

Dimensions: rim diam.: 14 cm; rim th.: 1.1 cm; wall th.: 0.8 cm.
Clay: outer and inner (self-slip) colour: 5Y 8/2 (pale yellow); fabric colour: 7.5YR 6/3 (light brown); sand inclusions; medium firing temperature.
Description: band rim jar.

AbT.13.169.4 - Fig. 8.32

Dimensions: rim diam.: 15 cm; rim th.: 0.6 cm; wall th.: 0.7 cm.
Clay: outer colour (slipped): 5Y 8/2 (pale yellow); inner colour (slipped): 2.5Y 8/3 (pale brown); fabric colour: 5YR 5/6 (yellowish brown); sand inclusions; medium firing temperature.
Description: band rim jar.

AbT.13.169.5 - Fig. 8.32

Dimensions: rim diam.: 18 cm; rim th.: 0.6 cm; wall th.: 1 cm.
Clay: outer colour (self-slip): 10YR 8/3 (pale brown); inner and fabric colour: 7.5YR 6/4 (light brown); sand inclusions; medium firing temperature.
Description: double-ridged rim jar.

Catalogue of US 185 (Grave 14) Finds

*Pottery***AbT.13.185.1 - Fig. 8.32**

Dimensions: rim diam.: 11 cm; rim th.: 0.6 cm; wall th.: 0.5 cm; base diam.: 5 cm; base th.: 0.7 cm; h.: 13.6 cm.
Clay: outer, inner and fabric colour: 10YR 5/4 (yellowish brown); sand inclusions; medium firing temperature.
Description: beaker found behind the head of the skeleton.

AbT.13.185.2 - Fig. 8.32

Dimensions: rim diam.: 10.9 cm; rim th.: 0.6 cm; wall th.: 0.6 cm; base diam.: 4.4 cm; base th.: 0.7 cm; h.: 12.4 cm.
Clay: outer colour: 10YR 8/2 (very pale brown); inner colour: 7.5YR 7/4

(pink); fabric colour: 5YR 4/3 (reddish brown); sand inclusions; medium-low firing temperature.
Description: beaker found in front of the skull.

AbT.13.185.3 - Fig. 8.32

Dimensions: rim diam.: 15 cm; rim th.: 0.5 cm; wall th.: 0.5 cm; base diam.: 5.4 cm; base th.: 0.9 cm; h.: 7.3 cm.
Clay: outer colour: 10YR 6/4 (light yellowish brown); inner colour: 7.5YR 6/6 (reddish yellow); fabric colour: 7.5YR 6/4 (light brown); sand inclusions; medium-low firing temperature.
Description: conical bowl found on the south side of the skeleton, over the leg.

AbT.13.185.4 - Fig. 8.32

Dimensions: rim diam.: 16 cm; rim th.: 0.6 cm; wall th.: 1 cm; base diam.: 5.1 cm; base th.: 1 cm; h.: 6.2 cm.
Clay: outer colour: 2.5Y 8/3 (pale brown); inner and fabric colour: 7.5YR 4/6 (strong brown); sand inclusions; medium-low firing temperature.
Description: conical bowl found on the west side of the skeleton, near the right foot.

AbT.13.185.5 - Fig. 8.32

Dimensions: rim diam.: 9 cm ca.; rim th.: 0.5 cm; wall th.: 0.5 cm; base diam.: 7 cm ca.; base th.: 0.7 cm; h.: 21.2 cm.
Clay: outer, inner and fabric colour: 10YR 8/3 (very pale brown); sand inclusions; medium-high firing temperature.
Description: jar with plain rim, rounded shoulder, ovoid body and convex base. Found near the hip.

AbT.13.185.6 - Fig. 8.32

Dimensions: rim diam.: 23 cm (inner); rim th.: 1.4 cm; wall th.: 0.8 cm.
Clay: outer colour: 5Y 8/3 (pale yellow); inner colour: 10YR 7/4 (very pale brown); fabric colour: 10YR 5/4 (yellowish brown); sand inclusions; medium firing temperature.
Description: triangular rim bowl.

Catalogue of US 185 (Grave 14)
Finds

Objects

AbT.13.87 - Fig. 8.31

Description: granite cube. Very regular surfaces with very little traces. Of the 6 surfaces 4 are very regular and rounded, whereas the other two are a little more irregular, the four rounded surfaces must have been either abraded or used to abrade some other surface. Very difficult to differentiate between

technological and functional traces due to the nature of the raw material. It seems more plausible that this artifact was worked and not used. [SC]
Dimensions: 3.8x3.8x3.8 cm; weight 63 g.

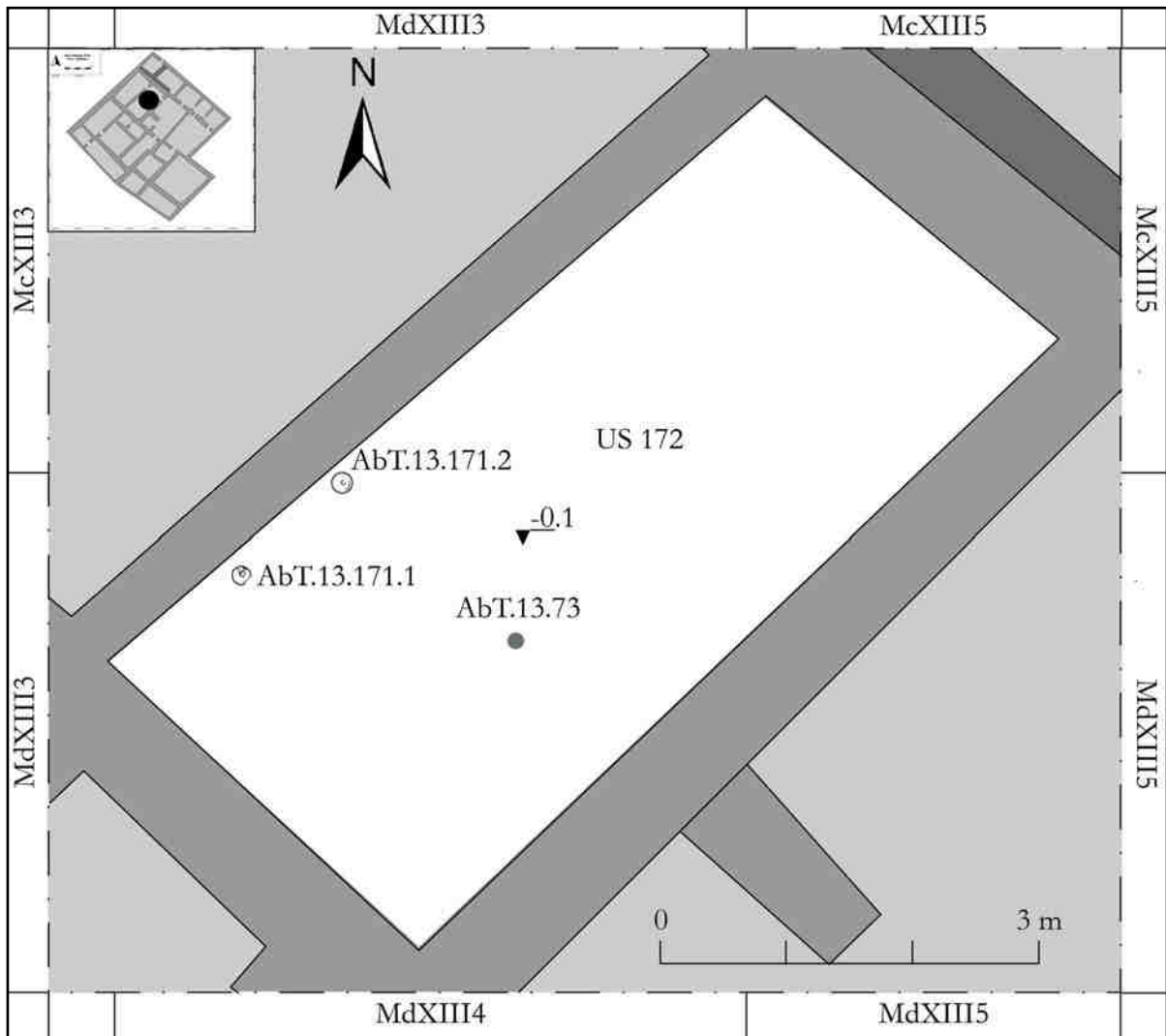

Fig. 8.33 Room 6 plan.

8.6 ROOM 6 [LR]

The Room (Fig. 8.33) was filled by a quite soft yellowish brown stratum (US 170), full of mud-brick fragments probably pertaining to the structure. The presence of a housing area (US 172) was reconstructed at the elevation of -0.1 m on the base of the presence of the so-called “foundation bowls” (US 171) and of a pestle. The pottery fragments discovered inside US 170 belonged to several drinking vessels (mainly rims; AbT.13.170.2-3) and to one triangular rim bowl (AbT.13.170.1). The other shapes discovered are: three convex bases of jars, one plain and two double-ridged rims of jars and two spouts. Several fragments of at least one big coarse vessel (a vat?) with flat base were collected.

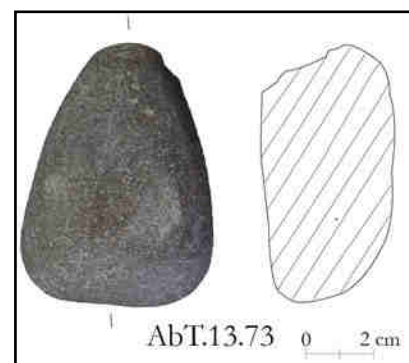

Fig. 8.34 US 172 objects.

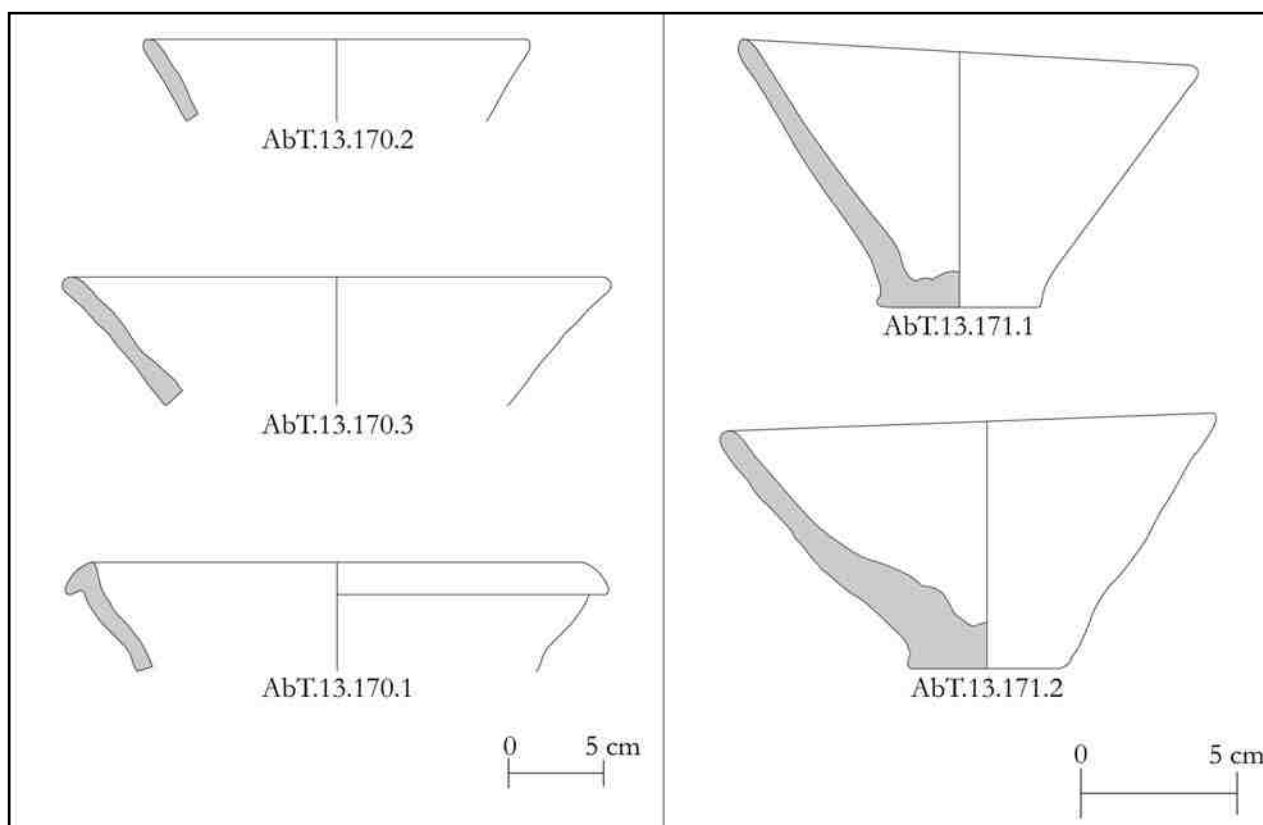

Fig. 8.35 US 170 and US 171 pottery.

Catalogue of US 170 Finds

Pottery

AbT.13.170.1 - Fig. 8.35

Dimensions: rim diam.: 26 cm; rim th.: 2.25 cm; wall th.: 1.3 cm.

Clay: outer colour (self-slip): 7.5YR 8/2 (pinkish white); inner colour (self-slip): 10YR 8/2 (very pale brown); fabric colour: 5YR 7/6 (reddish yellow); sand inclusions; medium firing temperature. Description: triangular rim bowl.

AbT.13.170.2 - Fig. 8.35

Dimensions: rim diam.: 20 cm (inner); rim th.: 0.9 cm; wall th.: 0.8 cm.

Clay: outer fabric colour (self-slip): 2.5Y 8.5/2 (pale yellow); inner colour (slipped): 2.5Y 8.5/2 (pale yellow); fabric colour: 5YR 7/4 (pink); sand inclusions; medium-high firing temperature.

Description: drinking vessel rim.

AbT.13.170.3 - Fig. 8.35

Dimensions: rim diam.: 28 cm ca.; rim th.: 1 cm; wall th.: 0.8 cm.

Clay: outer and inner fabric colour: 2.5Y 8/3 (pale brown); fabric colour:

5YR 5/4 (reddish brown); sand inclusions; medium firing temperature.

Description: drinking vessel rim. Traces of bitumen on the inner and outer surfaces.

Catalogue of US 171 Finds

Pottery

AbT.13.171.1 - Fig. 8.35

Dimensions: rim diam.: 14.7 cm; rim th.: 0.6 cm; wall th.: 0.6 cm; base th.: 0.5 cm; base diam.: 5.2 cm; h.: 8.6 cm.

Clay: outer colour: 7.5YR 7/3 (pink); inner colour: 2.5Y 8/3 (light reddish brown); fabric colour: 7.5YR 6/4 (light brown); sand inclusions; medium-low firing temperature.

Description: conical bowl found along the north-west wall.

AbT.13.171.2 - Fig. 8.35

Dimensions: rim diam.: 15.5 cm; rim th.: 0.6 cm; wall th.: 0.7 cm; base th.: 1.5 cm; base diam.: 5.9 cm; h.: 8.1 cm.

Clay: outer colour: 2.5Y 8/2 (pale brown); inner colour: 5YR 6/4 (pale brown); fabric colour: 2.5Y 7/4 (pale

brown); sand inclusions; medium firing temperature.

Description: conical bowl found along the north-west wall.

Catalogue of US 172 Finds

Objects

AbT.13.73 - Fig. 8.34

Description: stone pestle which was used uniquely for pestle-like activities. Maybe the flatter inferior surface was implemented for polishing activities. The only prolonged functional area (pestle functional area) presents traces of light pounding from a continuous utilization. [SC]

Dimensions: 5.4x7.45x3.7 cm.

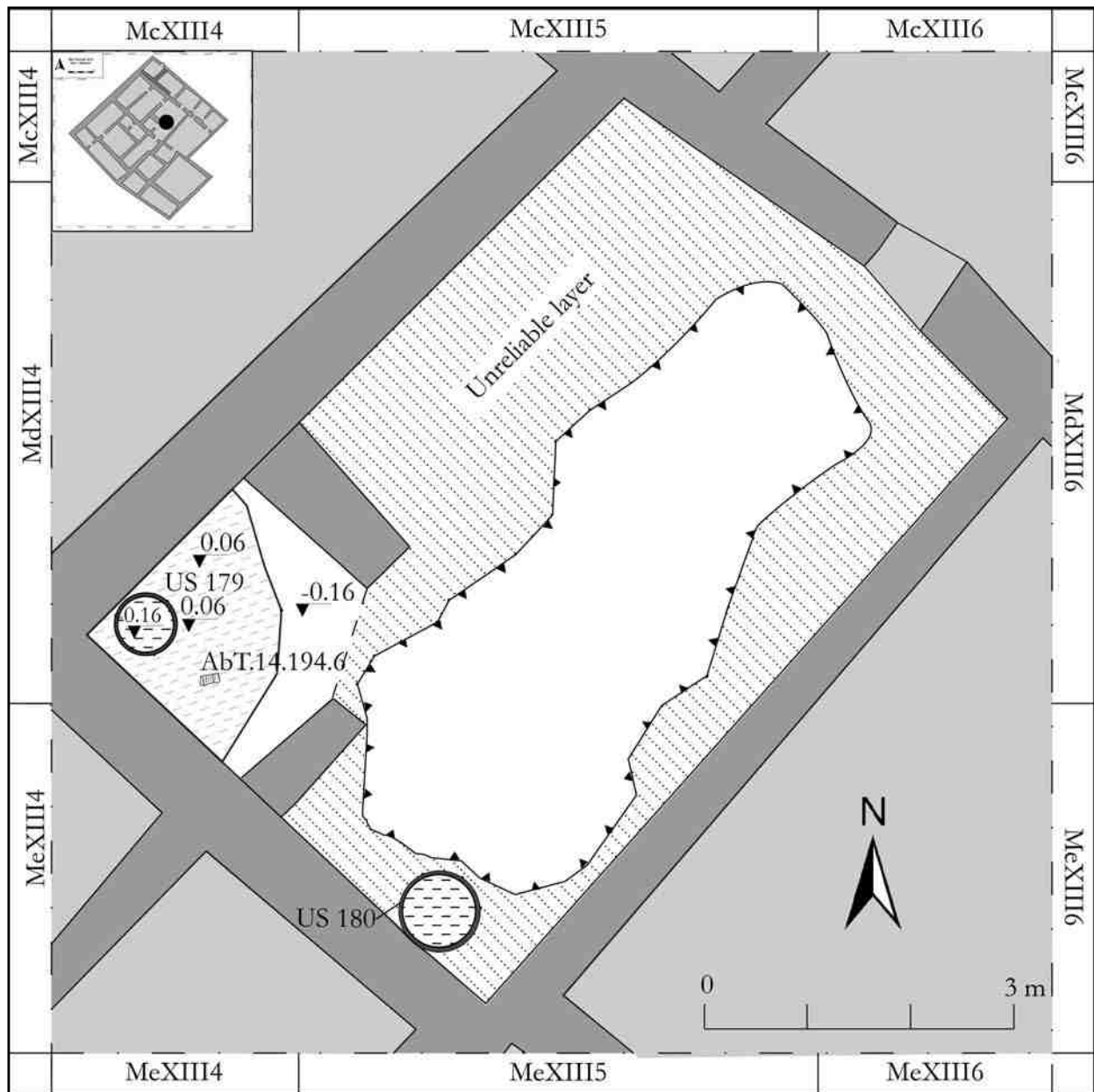

Fig. 8.36 Room 7.

8.7 ROOM 7 [LR]

Room 7 (Figs 7.36-37) was strongly damaged by later activities: the Room was cut by a huge dumping pit (US 242), this, in turn, was cut by Grave 15 and Grave 16. The cut was not clearly visible due to the nature of the soil and to post-depositional modifications (see § 6.1.1). A reliable stratigraphy was detected only in the west corner of the Room where two small walls protected a tannur (US 178; filling US 179 - Fig. 8.37) belonging to the first phase of the Building. While the tannur was preserved for an elevation of 0.4 m, its base was at the elevation of -0.16 m. The tannur was built over pavement US 249 and surrounded by a stratum of ashy soil (US 194) with some pottery discarded

inside it, mainly drinking vessels fragments, a cylinder and at least three different jars. The traces of a second tannur (US 180; filling US 181) were identified in the west corner of the Room during 2013 campaign, immediately under the surface, at the elevation of 0.1 m. It is, thus, not clear if this tannur was connected to later activities or to a later eroded phase of the Building. However, the position along the south-east wall seems to point towards a use in connection with the Room.



Fig. 8.37 Tannur US 178 in the north-western corner of Room 7.

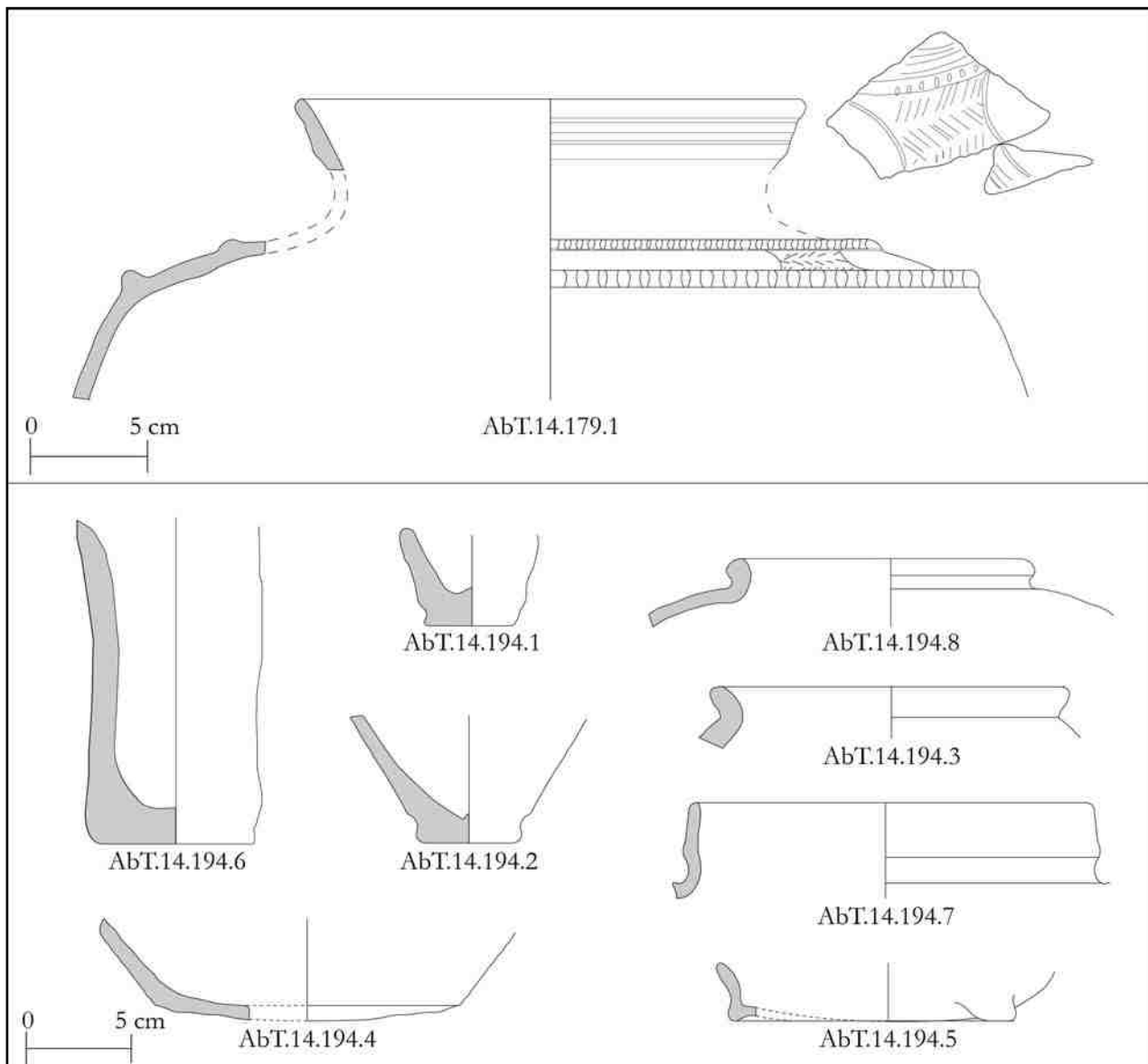

Fig. 8.38 US 179 and US 194 pottery.

Catalogue of US 179 Finds

*Pottery***AbT.14.179.1 - Fig. 8.38**

Dimensions: rim diam.: 26 cm; rim th.: 0.8 cm; wall th.: 0.8 cm.

Clay: outer and inner colour (slip): 2.5Y 8/4 (pale brown); fabric colour: 2.5YR 6/6 (light red); sand inclusions; medium firing temperature.

Description: band rim jar. Two notched ridges are used to frame the shoulder, that is decorated with two incised curves enclosing a herringbone pattern.

Catalogue of US 194 Finds

*Pottery***AbT.14.194.1 - Fig. 8.38**

Dimensions: wall th.: 1 cm; base diam.: 4.5 cm; base th.: 1.5 cm.

Clay: outer, inner and fabric colour: 5YR 7/6 (reddish yellow); sand inclusions; medium firing temperature. Description: beaker base.

AbT.14.194.2 - Fig. 8.38

Dimensions: wall th.: 0.6 cm; base diam.: 4.9 cm; base th.: 1.5 cm.

Clay: outer, inner and fabric colour: 7.5YR 8/3 (pink); sand inclusions; medium firing temperature.

Description: conical bowl base.

AbT.14.194.3 - Fig. 8.38

Dimensions: rim diam.: 16 cm; rim th.: 2.1 cm; wall th.: 1.1 cm.

Clay: outer, inner and fabric colour: 5YR 8/4 (pink); sand inclusions; medium-low firing temperature.

Description: plain rim jar.

AbT.14.194.4 - Fig. 8.38

Dimensions: wall th.: 0.7 cm; base diam.: 14 cm; base th.: 0.7 cm.

Clay: outer, inner and fabric colour: 5Y 8/2 (pale yellow); sand inclusions; high firing temperature.

Description: convex base.

AbT.14.194.5 - Fig. 8.38

Dimensions: wall th.: 0.6 cm; base diam.: 12 cm; base th.: 0.8 cm.

Clay: outer and inner colour (slip?): 5Y 8/2 (pale yellow); fabric colour: 5YR 6/6 (reddish yellow); sand inclusions; high firing temperature.

Description: convex base with three feet.

AbT.14.194.6 - Fig. 8.38

Dimensions: wall th.: 1.2 cm; base diam.: 8 cm; base th.: 1.2 cm.

Clay: outer and inner and fabric colour: 7.5YR 7/4 (pink); fabric colour: 7.5YR 6/4 (light brown); sand inclusions; medium firing temperature.

Description: cylinder base.

AbT.14.194.7 - Fig. 8.38

Dimensions: rim diam.: 14 cm; rim th.: 0.6 cm; wall th.: 0.7 cm.

Clay: outer, inner and fabric colour: 2.5YR 6/8 (light red); sand inclusions; medium firing temperature.

Description: band rim jar.

AbT.14.194.8 - Fig. 8.38

Dimensions: rim diam.: 13 cm; rim th.: 1 cm; wall th.: 0.7 cm.

Clay: outer colour: 2.5Y 8/3 (pale brown); inner and fabric colour: 5YR 6/4 (light reddish brown); sand inclusions; medium-high firing temperature.

Description: plain rim jar with bitumen traces.

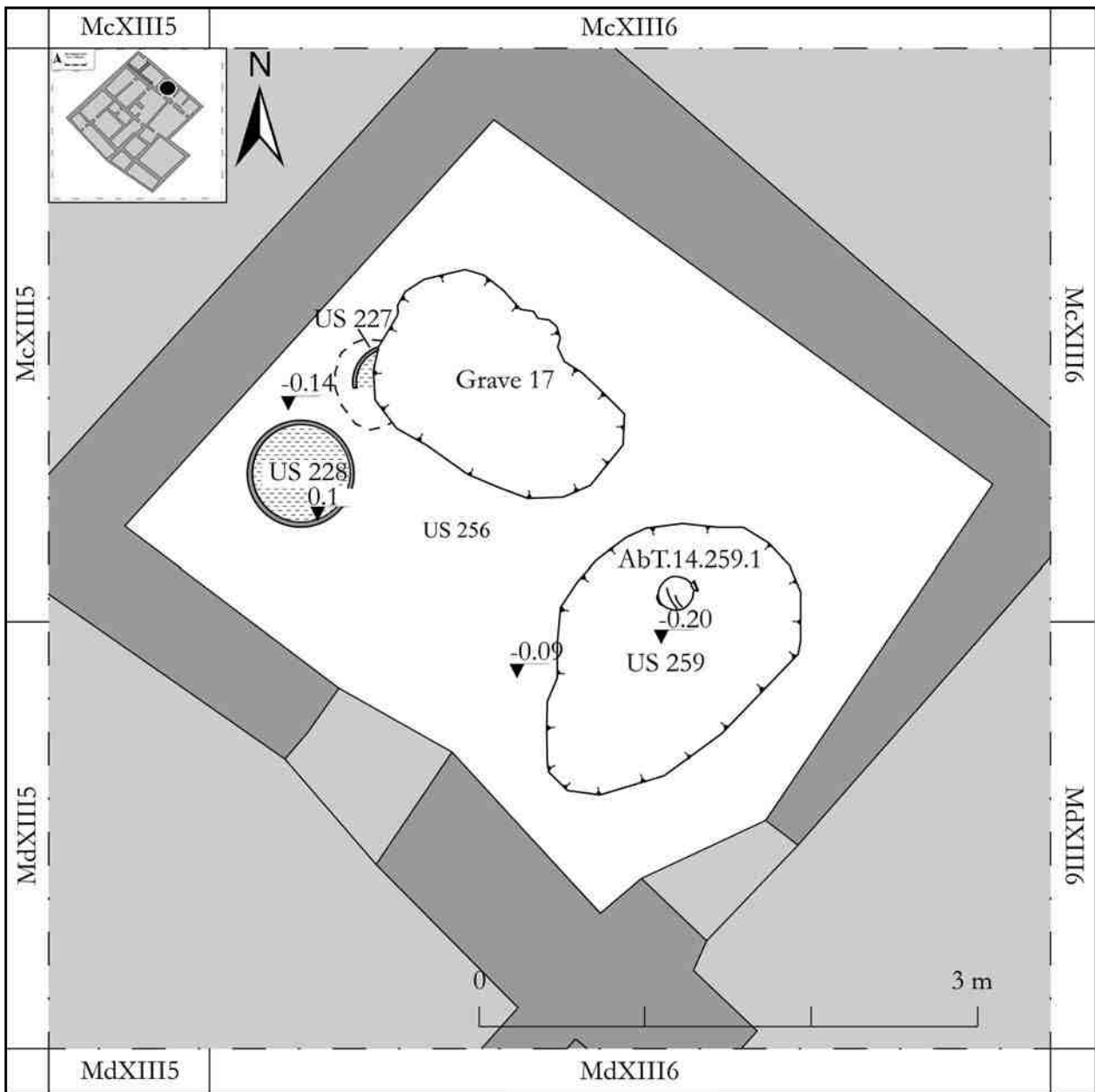

Fig. 8.39 Room 8 plan.

8.8 ROOM 8 [LR]

Room 8 filling (US 254 - Fig. 8.39) was cut by Grave 17. Probably this later activity caused a higher water infiltration inside the stratum that, thus, was characterized by several areas hardened by salt. Two tannur were located inside the Room: tannur US 228 (filling US 229; partially dug into the ground surface) and tannur US 227 (filling US 236),¹¹ the last one mostly destroyed by Grave

17.¹² The tannur were preserved up to 0.1 m of elevation, while their bases had an elevation of -0.13 m. The housing surface (US 256), clearly visible near the north-east wall, had the same elevation of the bases of the two tannur. In the stratum over the ground surface ca. 80 bases of drinking vessels were found, together with several

¹¹ During the excavation the realization of a cut to host the tannur's base was hypothesized. This hypothesis was based on the presence of strong salt incrustations around the firing structure. However, the salt incrustation could be due to

water infiltration, accentuated by the later activities, in the area of contact between the soil and the tannur's wall. US 258 is the backfill of the cut made to host the tannur.

¹² Fragments of the tannur were also in the filling between the sarcophagus US 225 and the cut.

jar fragments. A piece of bitumen (AbT.14.47), mixed to chaff, and a stone tool (AbT.14.55) were also recovered. Under the pavement, a cut of a shallow almost oval pit (US 260) filled by US 259 was identified, pertaining to the use of the Room (Fig. 8.40). The edge of the cut was covered by a series of small mud-brick fragments. On the bottom of the pit a complete jar (AbT.14.259.1), with bitumen traces on one side was discovered. In addition, other pottery fragments recovered inside US 259 were clearly exposed to fire.¹³



Fig. 8.40 Room 8. US 260 with AbT.14.259.1 on the bottom of the cut.

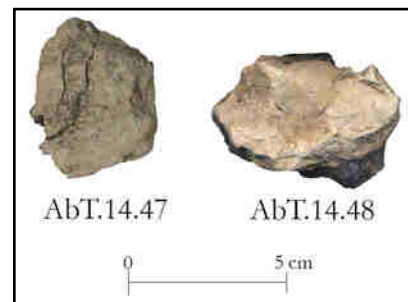

Fig. 8.41 US 254 objects.



Fig. 8.42 US 256 objects.

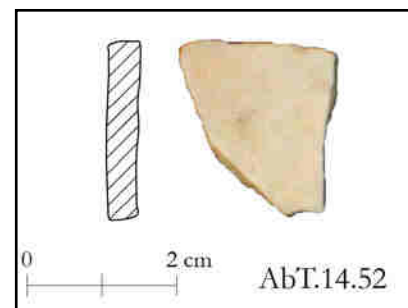

Fig. 8.43 US 259 objects.

¹³ In the earlier phase of the Room a rectangular firing structure were found, almost at the same elevation of the jar. Thus, it is also plausible that US 259 pottery (in particular the complete jar on the bottom of the pit) originally belonged to the earlier phase.

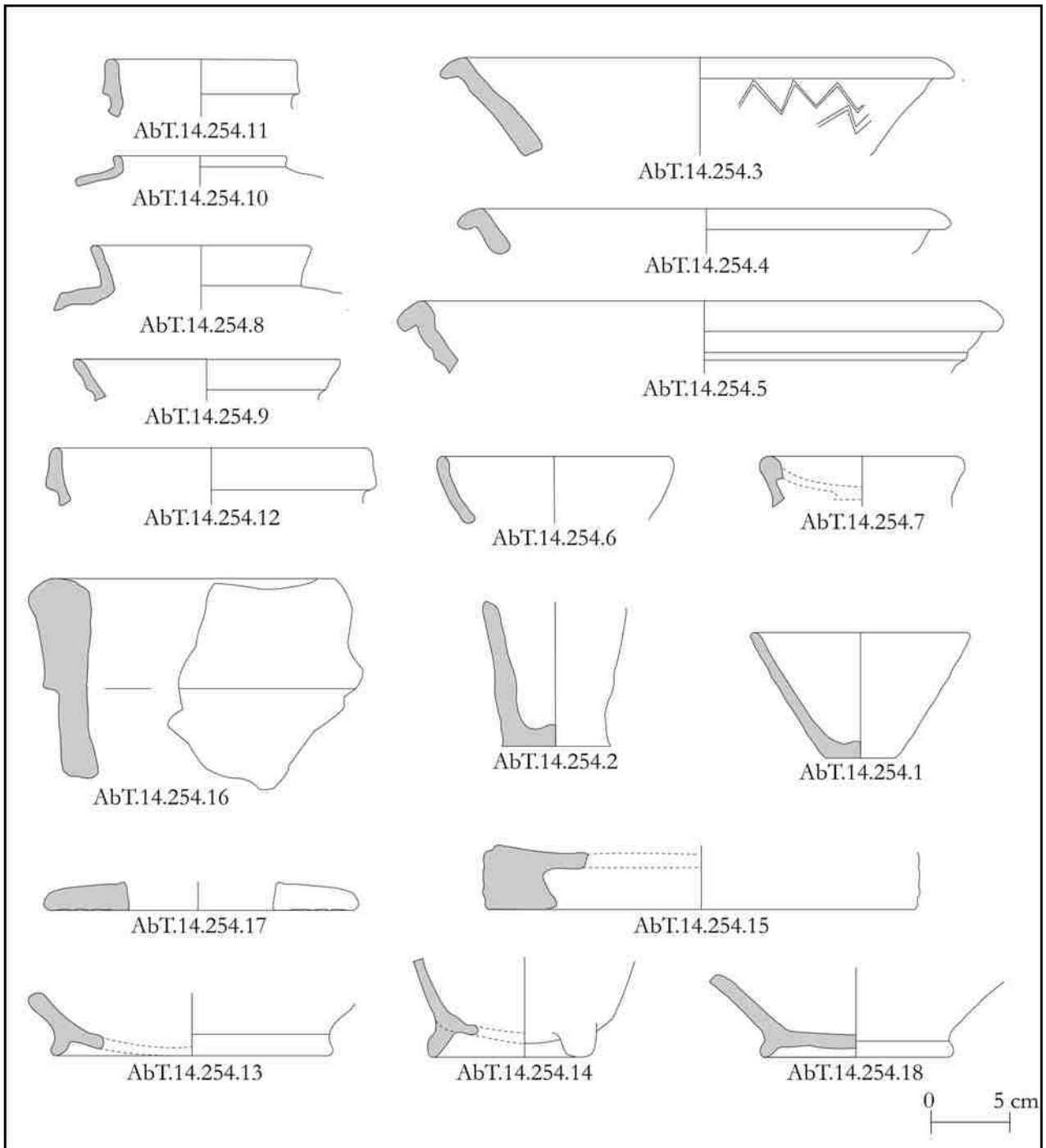

Fig. 8.44 US 254 pottery.

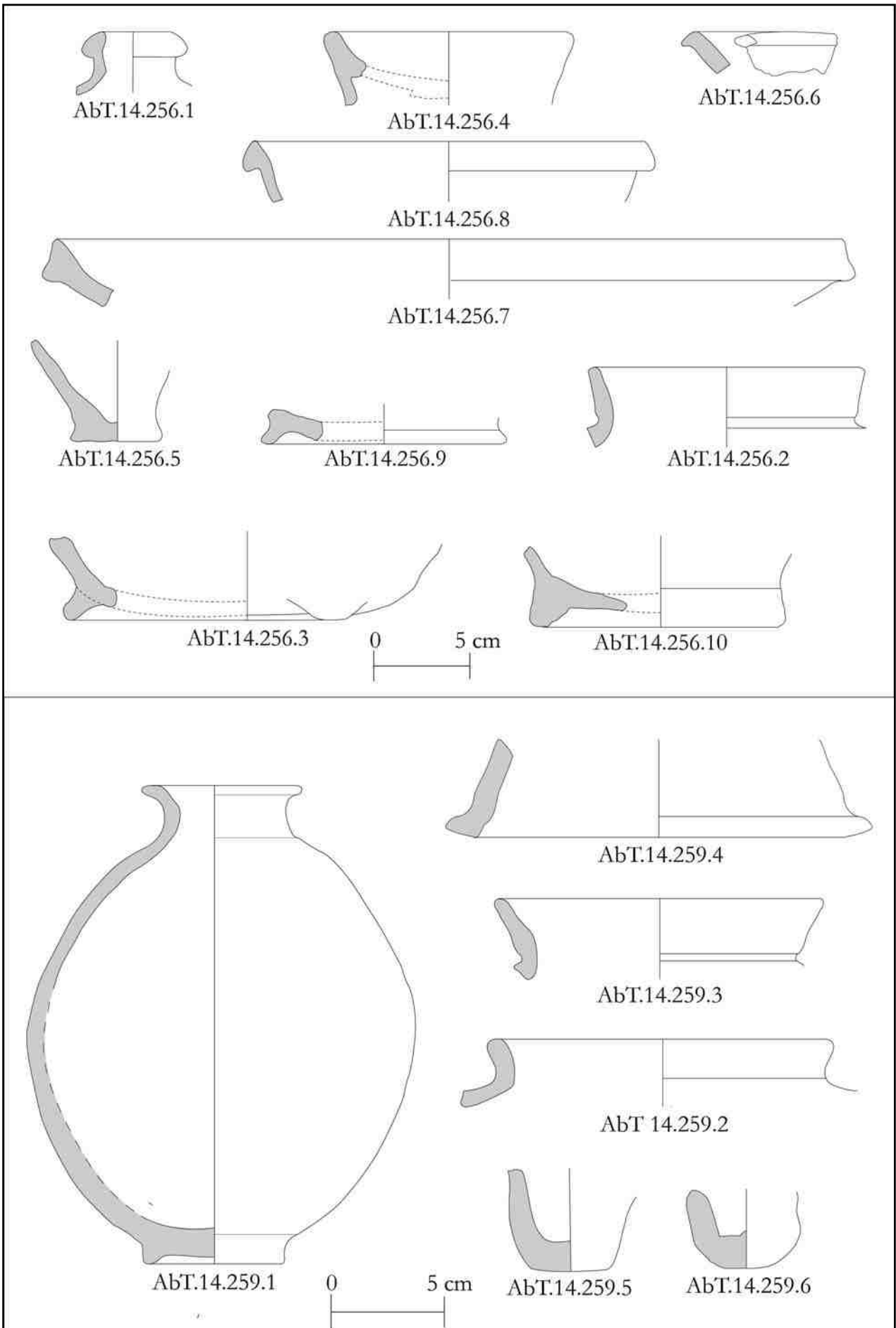

Fig. 8.45 US 256 and US 259 pottery.

Catalogue of US 254 Finds

*Objects***AbT.14.47 - Fig. 8.41**

Description: fragment of a bitumen object.

Dimensions: 7x4.2x2.4 cm.

AbT.14.48 - Fig. 8.41

Description: chert fragment.

Dimensions: 6.2x4.3x3.1 cm.

*Pottery***AbT.14.254.1 - Fig. 8.44**

Dimensions: rim diam.: 15 cm; rim th.: 0.7cm; wall th.: 0.7 cm; base diam.: 5 cm; base th.: 0.8 cm; h.: 9.1 cm.

Clay: outer, inner and fabric colour: 5YR 6/8 (reddish yellow); sand inclusions; medium-low firing temperature.

Description: conical bowl.

AbT.14.254.2 - Fig. 8.44

Dimensions: wall th.: 0.8 cm; base diam.: 6.5 cm; base th.: 1.5 cm.

Clay: outer and inner colour: 2.5Y 8/2 (pale brown); fabric colour: 5YR 7/6 (reddish yellow); sand inclusions; medium temperature.

Description: beaker base.

AbT.14.254.3 - Fig. 8.44

Dimensions: rim diam.: 30 cm; rim th.: 1.6 cm; wall th.: 1.1 cm.

Clay: outer and inner colour (self-slip): 2.5Y 8/3 (pale brown); fabric colour: 5YR 5/6 (yellowish red); sand inclusions; medium-high firing temperature.

Description: triangular rim bowl. The inner and outer surface is very eroded, however zigzag incisions are still visible.

AbT.14.254.4 - Fig. 8.44

Dimensions: rim diam.: 23 cm; rim th.: 2 cm; wall th.: 1.2 cm.

Clay: outer and inner colour: 5YR 8/4 (pink); fabric colour: 2.5YR 5/8 (red); sand inclusions; medium firing temperature.

Description: triangular rim bowl.

AbT.14.254.5 - Fig. 8.44

Dimensions: rim diam.: 26 cm; rim th.: 2 cm; wall th.: 0.9 cm.

Clay: outer and inner colour: 10YR 8/2 (very pale brown); fabric colour: 5YR 6/4 (light reddish brown); sand inclusions; medium-high firing temperature.

Description: triangular rim bowl with a ridge on the wall.

AbT.14.254.6 - Fig. 8.44

Dimensions: rim diam.: 9 cm; rim th.: 0.9 cm; wall th.: 0.8 cm.

Clay: outer and inner colour: 10YR 8/3 (very pale brown); fabric colour: 7.5YR 6/4 (pink); sand inclusions; low firing temperature.

Description: very small bowl with slightly in-turned rim.

AbT.14.254.7 - Fig. 8.44

Dimensions: rim diam.: 14 cm; rim th.: 1.5 cm; wall th.: 0.7 cm.

Clay: outer, inner and fabric colour: 7.5YR 6/4 (light brown); sand inclusions; low firing temperature.

Description: conical bowl attached to a stand.

AbT.14.254.8 - Fig. 8.44

Dimensions: rim diam.: 14 cm; rim th.: 0.6 cm; wall th.: 0.8 cm.

Clay: outer and inner colour: 2.5Y 8/2 (pale brown); fabric colour: 2.5YR 6/8 (light red); sand inclusions; high firing temperature.

Description: plain rim jar.

AbT.14.254.9 - Fig. 8.44

Dimensions: rim diam.: 15 cm; rim th.: 0.8 cm.

Clay: outer, inner and fabric colour: 2.5Y 8/2 (pale brown); sand inclusions; high firing temperature.

Description: band rim jar.

AbT.14.254.10 - Fig. 8.44

Dimensions: rim diam.: 9 cm; rim th.: 0.9 cm; wall th.: 0.6 cm.

Clay: outer and inner colour: 2.5Y 8/2 (pale brown); fabric colour: 5YR 7/4 (pink); sand inclusions; high firing temperature.

Description: plain rim jar.

AbT.14.254.11 - Fig. 8.44

Dimensions: rim diam.: 10 cm; rim th.: 0.9 cm; wall th.: 0.8 cm.

Clay: outer, inner and fabric colour: 2.5Y 7/3 (pale brown); sand inclusions; medium-high firing temperature.

Description: band rim jar.

AbT.14.254.12 - Fig. 8.44

Dimensions: rim diam.: 20(?) cm; rim th.: 0.8 cm; wall th.: 0.8 cm.

Clay: outer, inner and fabric colour: 5YR 6/8 (reddish yellow); sand inclusions; low firing temperature.

Description: band rim jar.

AbT.14.254.13 - Fig. 8.44

Dimensions: wall th.: 1.2 cm; base diam.: 17.5 cm; base th.: 1 cm.

Clay: outer colour: 2.5Y 8/3 (pale brown); inner colour: 7.5YR 8/3 (pink); fabric colour: 5YR 6/6 (reddish yellow); sand inclusions; medium-high firing temperature.

Description: ring base.

AbT.14.254.14 - Fig. 8.44

Dimensions: wall th.: 0.9 cm; base diam.: 11 cm; base th.: 0.6 cm.

Clay: outer and inner colour: 7.5YR 7/6 (reddish yellow); fabric colour: 7.5YR 5/4 (brown); sand inclusions; medium firing temperature.

Description: convex base with one foot preserved.

AbT.14.254.15 - Fig. 8.44

Dimensions: base diam.: 26 cm; base th.: 4.4 cm.

Clay: outer and inner colour: 7.5YR 7/6 (reddish yellow); fabric colour: 7.5YR 6/4 (light brown); sand and vegetal inclusions; medium-high firing temperature.

Description: ring base.

AbT.14.254.16 - Fig. 8.44

Dimensions: rim diam.: n.d.; rim th.: 4.2 cm; wall th.: 2.2 cm.

Clay: outer and inner colour: 7.5YR 6/4 (light brown); fabric colour: 5YR 5/3 (reddish brown); sand and vegetal inclusions; medium firing temperature.

Description: band rim of a vat/coarse jar.

AbT.14.254.17 - Fig. 8.44

Dimensions: rim th.: 1.2 cm; wall th.: 2 cm.

Clay: outer and inner colour: 2.5Y 3/1 (very dark grey); fabric colour: 2.5Y 8/1 (white); sand and vegetal inclusions; high firing temperature.

Description: disk covered with bitumen and organic substances. Unclear function (lid?).

AbT.14.254.18 - Fig. 8.44

Dimensions: wall th.: 1 cm; base diam.: 15 cm; base th.: 0.5 cm.

Clay: outer colour: 10YR 8/2 (very pale brown); inner colour: 10YR 8/3 (very pale brown); fabric colour: 7.5YR 6/4 (light brown); sand inclusions; medium-high firing temperature.

Description: ring base.

Catalogue of US 256 Finds

*Objects***AbT.14.55 - Fig. 8.42**

Description: fragment of a greyish stone pestle.

Dimensions: 3x2.9x1.7 cm.

*Pottery***AbT.14.256.1 - Fig. 8.45**

Dimensions: rim diam.: 4.9 cm; rim th.: 1.1 cm; wall th.: 0.6 cm.

Clay: outer and fabric colour: 2.5YR 7/8 (light red); inner colour: 7.5YR 7/6 (reddish yellow); sand inclusions; medium-low firing temperature.

Description: triangular rim miniaturistic jar/spout?

AbT.14.256.2 - Fig. 8.45

Dimensions: rim diam.: 14 cm; rim th.: 0.6 cm.

Clay: outer colour: 2.5Y 8/2 (pale brown); inner colour: 2.5YR 7/8 (light red); fabric colour: 5YR 6/6 (reddish yellow); sand inclusions; medium-high firing temperature.

Description: band rim jar.

AbT.14.256.3 - Fig. 8.45

Dimensions: wall th.: 1.1 cm; base diam.: 16(?) cm; base th.: 1.3 cm.

Clay: outer and inner colour: 5YR 6/4 (light reddish brown); fabric colour: 5YR 5/6 (yellowish red); sand inclusions; medium firing temperature.

Description: convex base with three feet.

AbT.14.256.4 - Fig. 8.45

Dimensions: rim diam.: 12 cm; rim th.: 1.4 cm; wall th.: 0.8 cm.

Clay: outer and inner colour: 10YR 8/2 (very pale brown); fabric colour: 5YR 6/6 (reddish yellow); sand inclusions; medium firing temperature.

Description: conical bowl attached to a stand.

AbT.14.256.5 - Fig. 8.45

Dimensions: wall th.: 0.5 cm; base diam.: 5 cm; base th.: 0.8 cm.

Clay: outer, inner and fabric colour: 5YR 7/6 (reddish yellow); sand inclusions; medium firing temperature.

Description: beaker base.

AbT.14.256.6 - Fig. 8.45

Dimensions: rim th.: 1.4 cm.

Clay: outer and inner colour: 10YR 8/2 (very pale brown); fabric colour: 7.5YR 6/4 (light brown); sand inclusions; medium-high firing temperature.

Description: triangular bowl.

AbT.14.256.7 - Fig. 8.45

Dimensions: rim diam.: 40 cm; rim th.: 2.1 cm; wall th.: 1 cm.

Clay: outer, inner and fabric colour: 2.5Y 8/2 (pale brown); sand inclusions; medium-high firing temperature.

Description: triangular rim bowl.

AbT.14.256.8 - Fig. 8.45

Dimensions: rim diam.: 15 cm; rim th.: 1.6 cm; wall th.: 0.6 cm.

Clay: outer colour: 2.5Y 8/2 (pale brown); inner and fabric colour: 7.5YR 7/4 (pink); sand inclusions; medium firing temperature.

Description: triangular rim bowl.

AbT.14.256.9 - Fig. 8.45

Dimensions: wall th.: 0.7 cm; base diam.: 13 cm; base th.: 1.1 cm.

Clay: outer, inner and fabric colour: 5YR 6/6 (reddish yellow); sand inclusions; medium-low firing temperature.

Description: ring base.

AbT.14.256.10 - Fig. 8.45

Dimensions: wall th.: 0.7 cm; base diam.: 13 cm; base th.: 0.5 cm.

Clay: outer, inner and fabric colour: 10YR 8/3 (very pale brown); sand and vegetal inclusions; medium firing temperature.

Description: ring base.

Catalogue of US 259 Finds

*Objects***AbT.14.52 - Fig. 8.43**

Description: limestone vessel.

Dimensions: 3x2.2x0.5 cm

*Pottery***AbT.14.259.1 - Fig. 8.45**

Dimensions: rim diam.: 5.7 cm; rim th.: 1.2 cm; wall th.: 0.5 cm; base diam.: 6.2 cm; base th.: 1 cm; h.: 22.1 cm.

Clay: outer colour: 5YR 5/4 (reddish brown); sand inclusions; low firing temperature.

Description: jar with out-turned rim and ring base.

AbT.14.259.2 - Fig. 8.45

Dimensions: rim diam.: 16 cm; rim th.: 0.9 cm; wall th.: 0.7 cm.

Clay: outer, inner and fabric colour: 2.5YR 5/6 (red); sand inclusions; low firing temperature.

Description: plain rim jar.

AbT.14.259.3 - Fig. 8.45

Dimensions: rim diam.: 13 cm; rim th.: 0.7 cm.

Clay: outer and inner colour: 2.5Y 8/3 (pale brown); fabric colour: 2.5YR 6/6 (light red); sand inclusions; medium-high firing temperature.

Description: band rim jar.

AbT.14.259.4 - Fig. 8.45

Dimensions: rim diam.: 23 cm; rim th.: 1.7 cm; wall th.: 1 cm.

Clay: outer and inner colour: 2.5Y 8/3 (pale brown); fabric colour: 2.5YR 5/6 (red); sand inclusions; medium-high firing temperature.

Description: stemmed-dish base.

AbT.14.259.5 - Fig. 8.45

Dimensions: base diam.: 2.5 cm; base th.: 1.3 cm.

Clay: outer, inner and fabric colour: 5YR 5/4 (reddish brown); sand inclusions; low firing temperature.

Description: almost pointed base.

AbT.14.259.6 - Fig. 8.45

Dimensions: base th.: 1 cm.

Clay: outer, inner and fabric colour: 7.5YR 5/4 (brown); sand inclusions; medium-high firing temperature.

Description: pointed base.

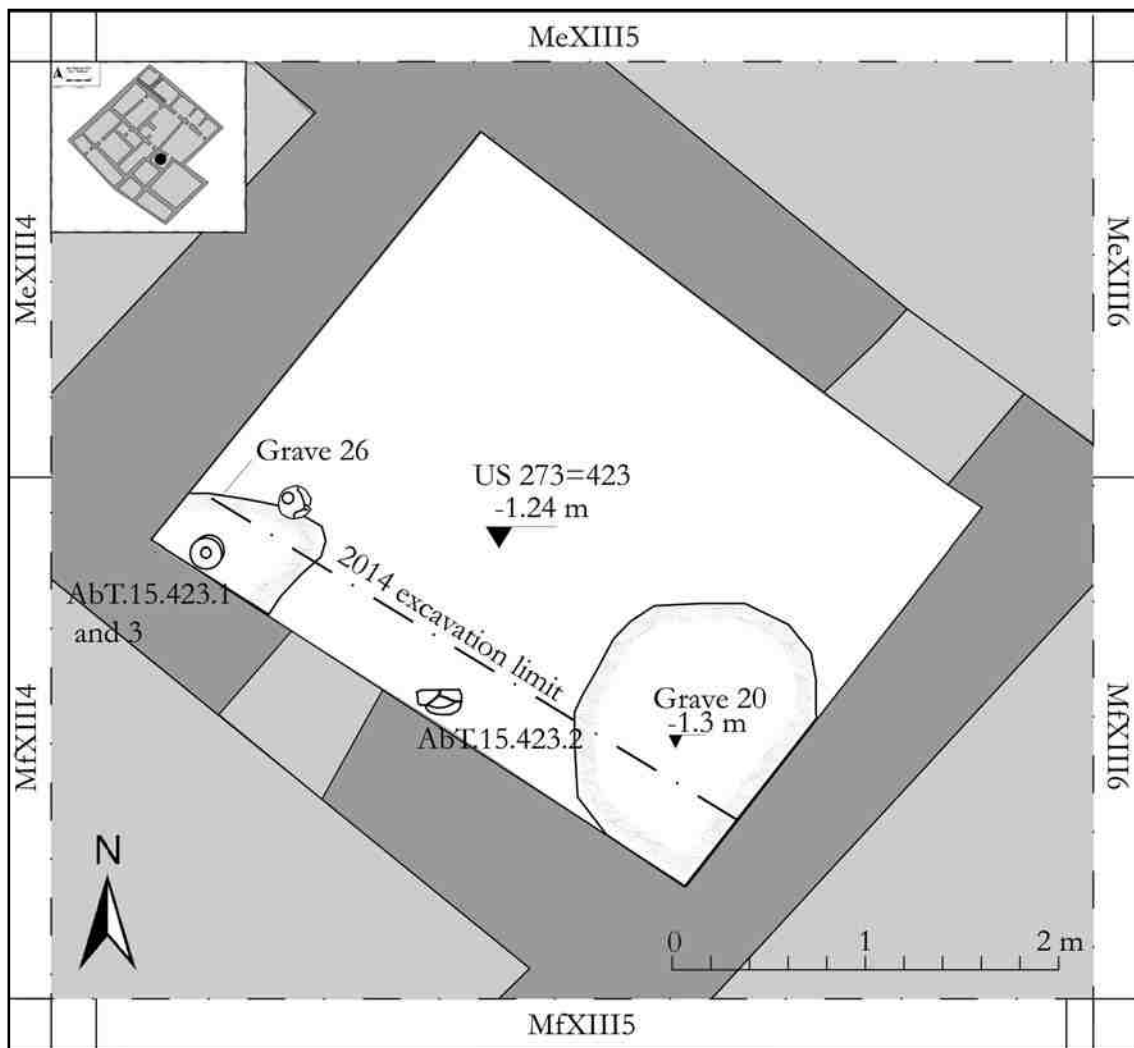

Fig. 8.46 Room 9.

8.9 ROOM 9 [LR]

Room 9 (Fig. 8.46) was excavated during 2014, but in 2015 it was necessary to reconsider the south-east limits of the space: the south-east mud-brick wall had, indeed, collapsed inside the Room, leading to a wrong interpretation of the dimensions of the space. Moreover, the distinction among the strata in this area was made more complex by the later activities that almost obliterated the Room in the satellite imagery (see Fig. 6.4). The Room was filled by a clay stratum full of mud-brick fragments (US 270=422), containing mostly drinking vessels sherds. Some objects, probably pertaining to the use of the Room, were found in the stratum (such as the stone tool AbT.14.80). The housing surface (US 273=423) was identified at the elevation of -0.2 m during 2014 thanks to the presence of a reversed conical bowl near the western corner (US 274). Unfortunately, the conical bowl was looted by some Bedouin whose encampment was near

the Tell.¹⁴ However, during the 2015 excavations a set of two conical bowls was found near the same corner at the elevation of -0.1 m.¹⁵ A rounded shoulder of a jar was found on the ground-surface at the same elevation. A grave of an infant was under the pavement (Grave 20; US 275-276-277; Figs 8.47 and 49) was found, the bottom of which was at an elevation of -0.3 m. The body, in poor conditions, was apparently deposited on his right side with the head toward south-east, looking

¹⁴ The day after the discovery of the bowl, the area was completely destroyed and all the pottery scattered around the excavation. Near the limits of the area several prints of a man's naked foot were visible. Unfortunately, also the skeleton and the equipment of Grave 20 was destroyed. Only the base of the conical bowl was recovered with another fragment (AbT.14.274.2), the provenance of which is not clear.

¹⁵ The two conical bowls were assigned to US 423.

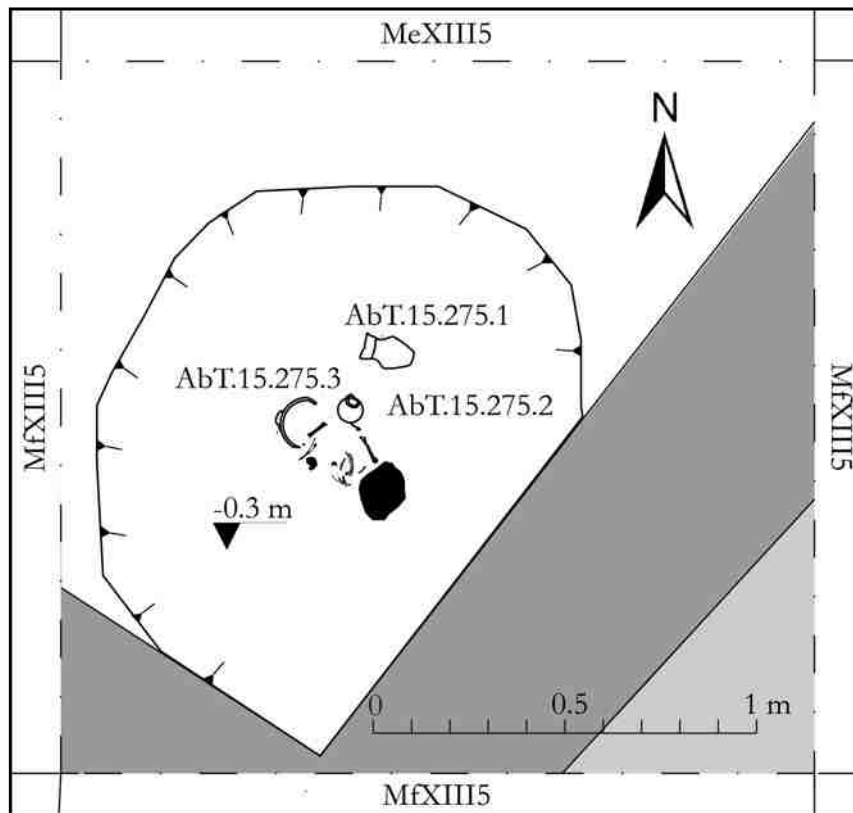

Fig. 8.47 Room 9. Grave 20 plan.

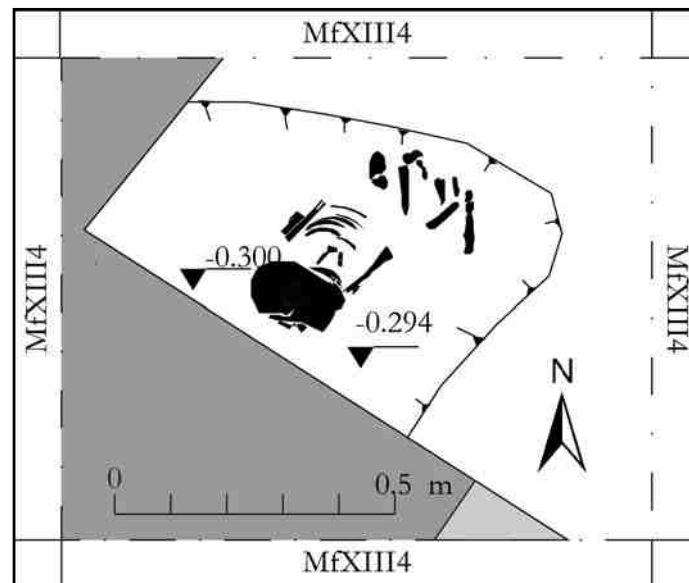

Fig. 8.48 Room 9. Grave 26 plan.

north-east, and the legs bent. The equipment (US 275) consisted of two miniaturistic jars and a conical bowl.

In the western corner there was a second infant grave (Grave 26, US 426-428-427; Figs 8.49

and 51).¹⁶ The body was placed in a semi-flexed position, with the head towards south-west and looking east, the legs bent.

¹⁶ The conical bowl was immediately over Grave 26, but it seemed not to be part of the funerary equipment.



Fig. 8.49 Room 9. Grave 20 from south-east.



Fig. 8.50 Room 9. Grave 26 from north-west.

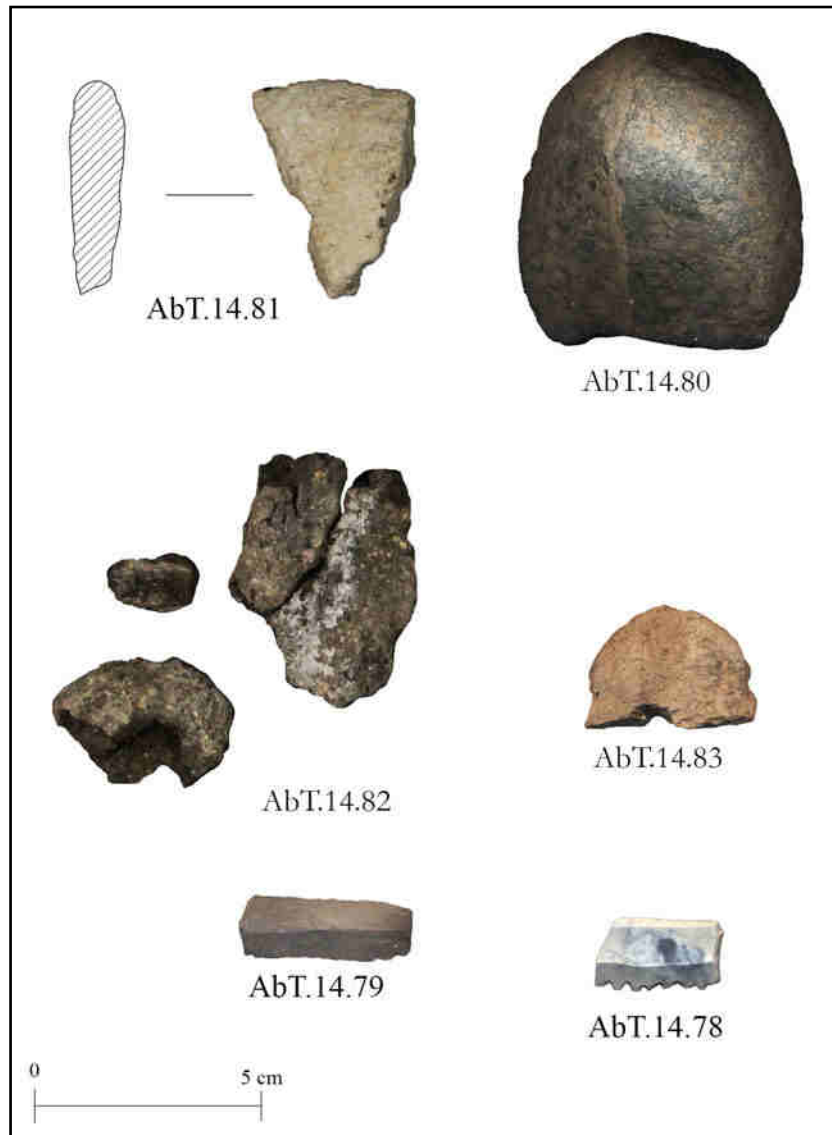

Fig. 8.51 US 270 objects.

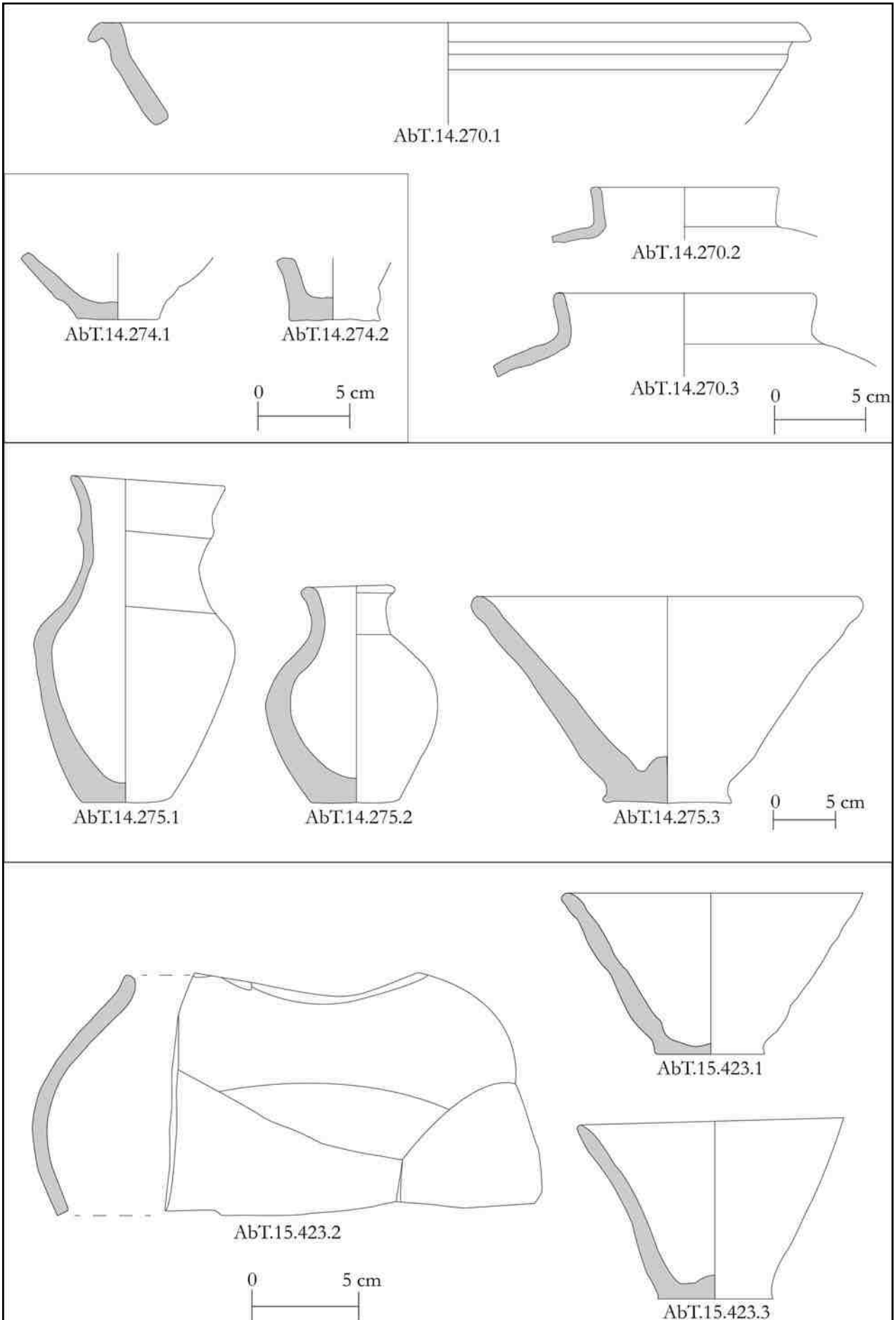

Fig. 8.52 US 270, US 274, US 275 and US 423 pottery.

Catalogue of US 270=422 Finds

*Objects***AbT.14.78 - Fig. 8.51**

Description: chert sickle element.
Dimensions: 2.9x1.7x0.3 cm.

AbT.14.79 - Fig. 8.51

Description: chert blade.
Dimensions: 3.7x1.3x0.3 cm.

AbT.14.80 - Fig. 8.51

Description: fragment of a basalt pestle.
Dimensions: 7.4x7.3x3.2 cm.

AbT.14.81 - Fig. 8.51

Description: rim fragment of a limestone vessel.
Dimensions: 3.1x4.5x1.1 cm.

AbT.14.82 - Fig. 8.51

Description: fragments of at least one bitumen object.
Dimensions: 3.7x4.9x2.1 cm.

AbT.14.83 - Fig. 8.51

Description: half of a clay object pierced in the middle.
Dimensions: 3.9x2.5x0.5 cm.

*Pottery***AbT.14.270.1 - Fig. 8.52**

Dimensions: rim diam.: 34 cm; rim th.: 2 cm; wall th.: 1.1 cm.
Clay: outer and inner colour: 2.5Y 8/3 (pale brown); fabric colour: 5Y 6/6 (olive yellow); sand inclusions; medium firing temperature.
Description: triangular rim bowl.

AbT.14.270.2 - Fig. 8.52

Dimensions: rim diam.: 10 cm; rim th.: 0.7 cm; wall th.: 0.6 cm.
Clay: outer, inner and fabric colour: 5Y 7/3 (pale yellow); sand inclusions; medium-high firing temperature.
Description: plain rim jar.

AbT.14.270.3 - Fig. 8.52

Dimensions: rim diam.: 14 cm; rim th.: 0.6 cm; wall th.: 0.7 cm.
Clay: outer, inner and fabric colour: 2.5Y 8/3 (pale brown); sand inclusions; high firing temperature.
Description: plain rim jar.

Catalogue of US 273=423 Finds

*Pottery***AbT.15.423.1 - Fig. 8.52**

Dimensions: rim diam.: 14.5 cm; rim th.: 0.6 cm; wall th.: 0.6 cm; base diam.: 5 cm; base th.: 0.7 cm; h.: 7.5 cm.
Clay: outer and inner colour: 10YR 6/4 (light yellowish brown); fabric colour: 10YR 6/6 (brownish yellow); sand inclusions; medium-low firing temperature.
Description: conical bowl.

AbT.15.423.2 - Fig. 8.52

Dimensions: wall th.: 0.7 cm.
Clay: outer and inner colour: 10YR 7/2 (light grey); fabric colour: 10YR 6/3 (pale brown); sand inclusions; medium-high firing temperature.
Description: jar shoulder.

AbT.15.423.3 - Fig. 8.52

Dimensions: rim diam.: 15 cm; rim th.: 0.6 cm; wall th.: 0.7 cm; base diam.: 5.2 cm; base th.: 0.8 cm; h.: 7 cm.
Clay: outer, inner and fabric colour: 7.5YR 7/4 (pink); sand inclusions; medium-low firing temperature.
Description: conical bowl.

Catalogue of US 274 Finds

*Pottery***AbT.14.274.1 - Fig. 8.52**

Dimensions: wall th.: 0.9 cm; base diam.: 4.9 cm; base th.: 1.9 cm.
Clay: outer colour: 2.5Y 8/3 (pale brown); inner and fabric colour: 7.5YR 6/4 (light brown); sand inclusions; medium firing temperature.
Description: conical bowl base.

AbT.14.274.2 - Fig. 8.52

Dimensions: wall th.: 1 cm; base diam.: 5.5 cm; base th.: 1 cm.
Clay: outer and inner: 2.5Y 8/2 (pale brown); fabric colour: 7.5YR 6/4 (light brown); sand inclusions; medium-low firing temperature.
Description: beaker base.

Catalogue of US 275 Finds

*Pottery***AbT.14.275.1 - Fig. 8.52**

Dimensions: rim diam.: 6 cm; rim th.: 0.5 cm; wall th.: 0.4 cm; base diam.: 3.7 cm; h.: 13 cm.
Clay: outer, inner and fabric colour: 5YR 6/6 (reddish yellow); sand inclusions; medium-low firing temperature.
Description: miniaturistic jar with band rim, rounded shoulder and string-cut base.

AbT.14.275.2 - Fig. 8.52

Dimensions: rim diam.: 4.4 cm; rim th.: 0.6 cm; wall th.: 0.5 cm; base diam.: 4.3 cm; h.: 9 cm.
Clay: outer, inner and fabric colour: 5Y 8/2 (pale yellow); sand inclusions; medium-high firing temperature.
Description: miniaturistic jar with beveled rim, string cut base and a small hole on the base repaired before firing with clay.

AbT.14.275.3 - Fig. 8.52

Dimensions: rim diam.: 14 cm; rim th.: 0.7 cm; base diam.: 5.5 cm; base th.: 2 cm; h.: 8.4 cm.
Clay: outer, inner and fabric colour: 5YR 7/6 (reddish yellow); sand inclusions; medium firing temperature.
Description: conical bowl.

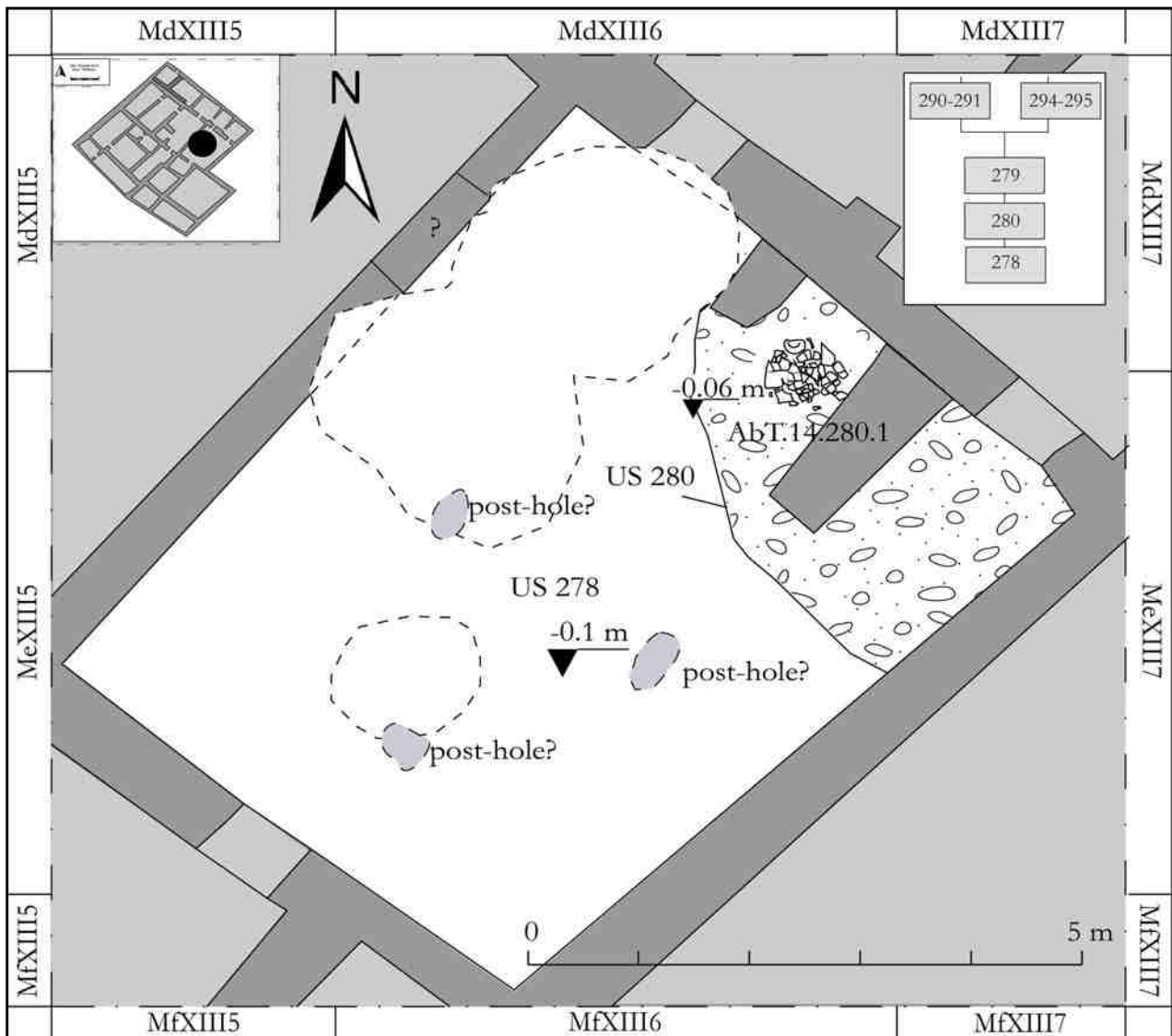

Fig. 8.53 Room 10 plan.

8.10 ROOM 10 [LR]

The stratigraphy inside the Room was disturbed by several later activities (Figs 8.53-54). The filling of the Room, a silty clay soil full of ashes (US 279), was cut by a series of pits, probably connected to the dumping/discharge activities carried out here in the later phases (see § 7.2.3). Only along the north-east wall, under a layer made of collapsed mud-bricks (US 280), fragments of a big jar were found *in situ* on the ground surface (US 278; elevation -0.1 m). The jar was placed between two small parallel mud structures at an higher elevation than the pavement.¹⁷

At the beginning three post-holes were identified and are reported in the plan. Unfortunately after a rainy day their traces were no more visible. No other evidence of occupation was detected during the excavations.

¹⁷ The two small clay structures were badly eroded (no mud-brick was identified) and preserved for an high of few centimeters. There was no clear sign of the use of mud-bricks in the construction of this installation (pisé?).



Fig. 8.54 Room 10 from south-west.

Catalogue of US 280 Finds

Pottery

AbT.14.280.1 - Fig. 8.55

Dimensions: base diam.: 14.5 cm; base th.: 0.8 cm; h.: 57 cm.

Clay: outer colour: 10YR 8/2 (very pale brown); inner colour: 5YR 6/4 (light reddish brown); fabric colour: 5YR 7/8 (reddish yellow); sand inclusions; medium firing temperature.

Description: big coiled jar with convex base and a hole near the base.

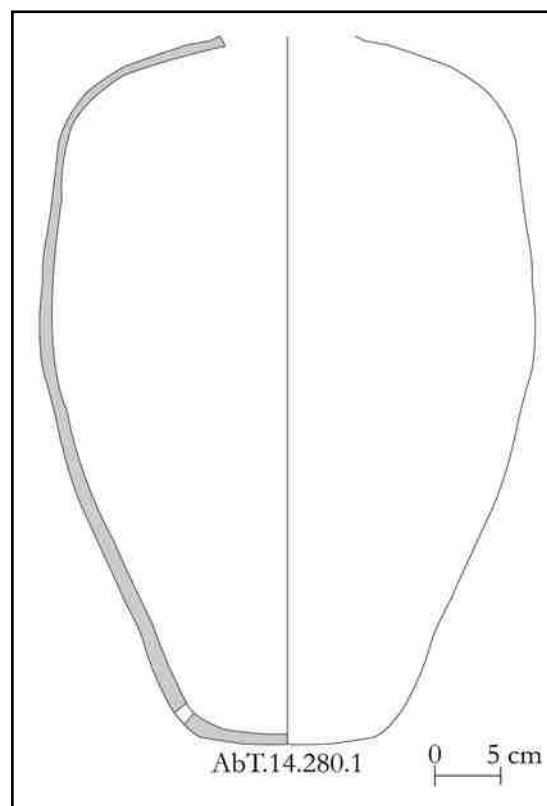

Fig. 8.55 US 280 pottery.

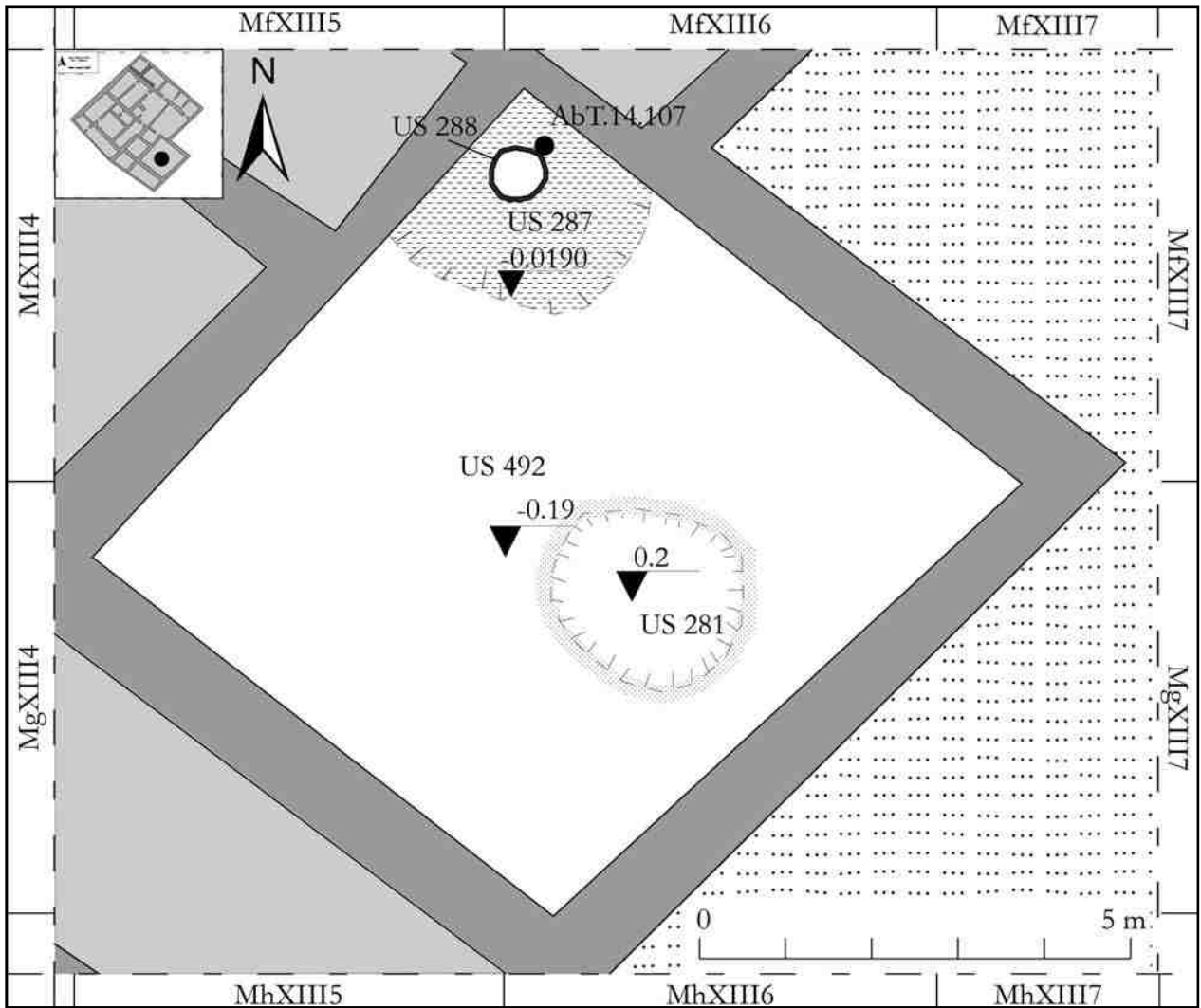

Fig. 8.56 Room 11 plan.

8.11 ROOM 11 [LR]

Room 11 (Fig. 8.56) is a big open space located in the south-east part of the building. The first stratum filling the Room is US 297=382: it followed the inclination of the area from north-east to south-west and was formed during the abandonment by the seasonal accumulation of a series of lenses of yellowish and greyish colour. It contained mostly drinking vessel fragments and some jar fragments with bitumen traces. The US covered a tannur located in the northern angle of the Room (US 288; filling US 289) and a heap of ashy soil (US 287). The pottery visible near the tannur (originally comprising also a small jar) was damaged during the same act of vandalism, suffered by the contexts inside Room 9 (see above). Only few pottery fragments (7 ca.) were recovered, most of them drinking vessels. The supposed pavement (US 492) was reconstructed



Fig. 8.57 US 281 objects.

at the elevation of -0.19 m, the same of the tannur base. In the south-east part of the Room a heap of sandy-clay dark soil (US 281) with lots of pottery fragments (mainly drinking vessels) was found.

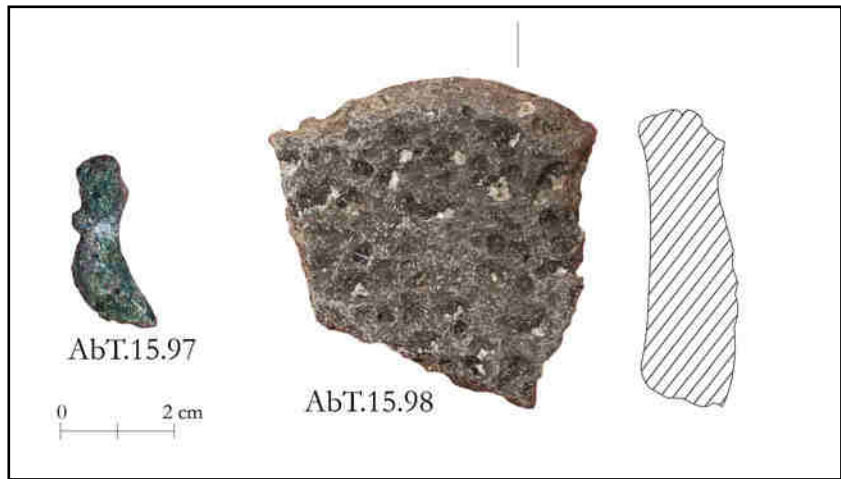
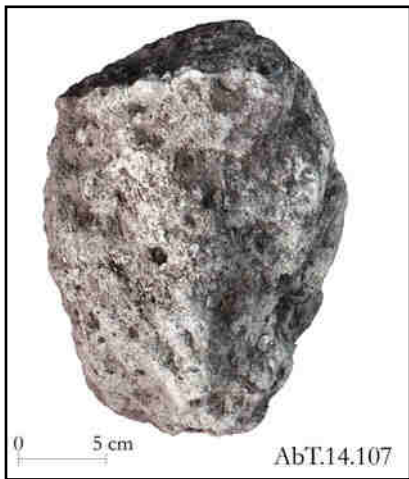

Fig. 8.58 US 287 objects.

Fig. 8.59 US 382 objects.

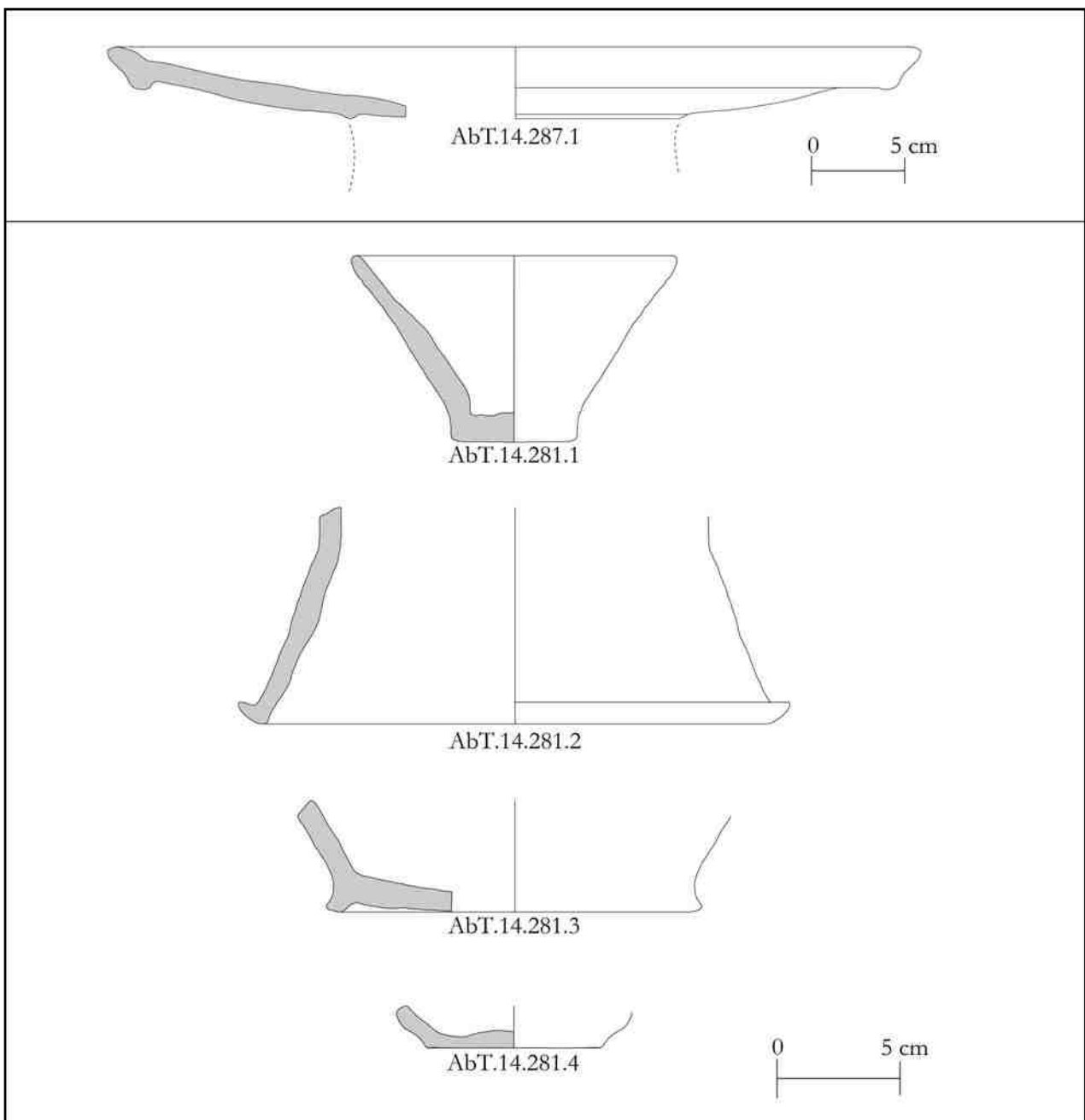

Fig. 8.60 US 281 and US 287 pottery.

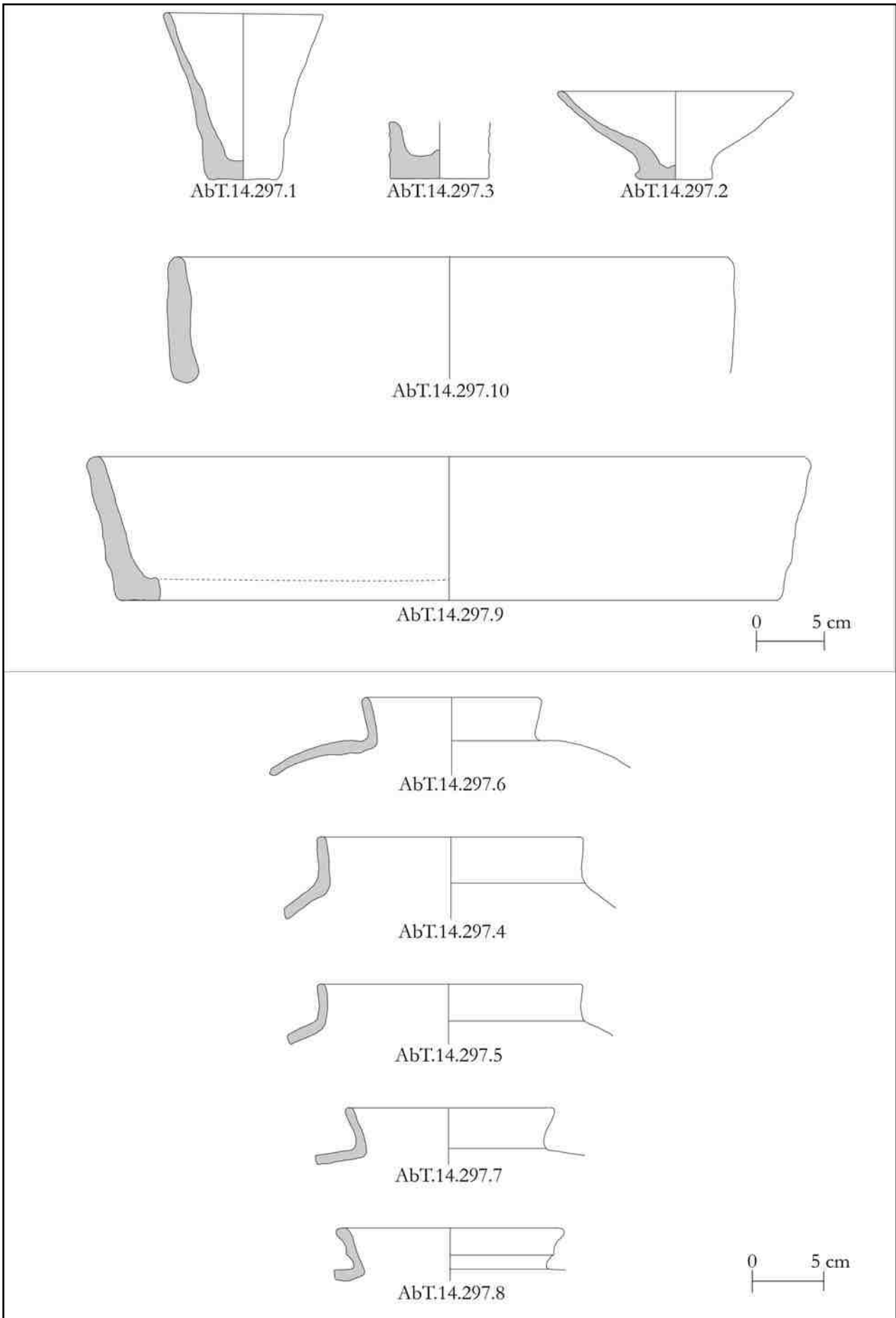

Fig. 8.61 US 297 pottery.

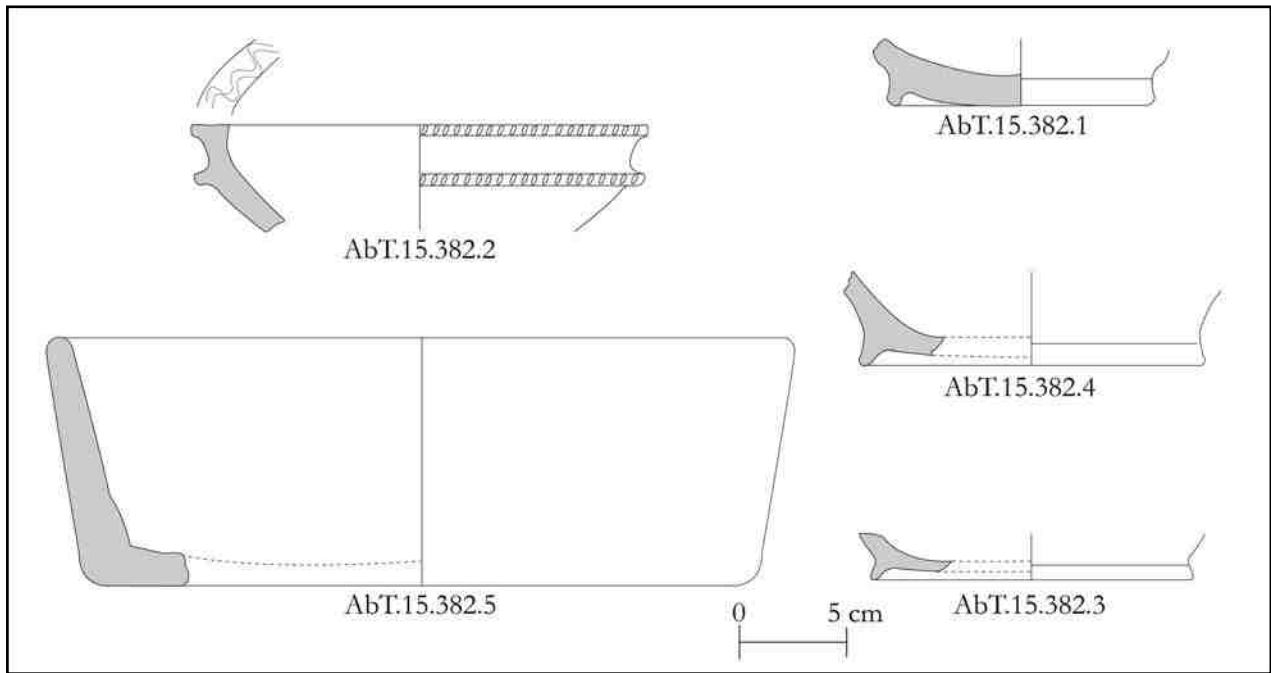

Fig. 8.62 US 297 pottery.

Catalogue of US 281 Finds

Objects

AbT.14.86 - Fig. 8.57

Description: chert blade.

Dimensions: 5.3x1.4x0.3 cm.

AbT.14.89 - Fig. 8.57

Description: small pear-shaped clay object.

Dimensions: 1.8x1.5x1.2 cm.

AbT.14.90 - Fig. 8.57

Description: copper alloy point.

Dimensions: 1.1x0.5x4.5 cm.

AbT.14.92 - Fig. 8.57

Description: chert blade.

Dimensions: 6.5x1.4x0.3 cm

Pottery

AbT.14.281.1 - Fig. 8.60

Dimensions: rim diam.: 15 cm; rim th.: 0.6 cm; wall th.: 0.7 cm; base diam.: 4 cm; base th.: 1 cm; h.: 3.4 cm.

Clay: outer and inner colour (slip): 2.5YR 8/3 (pink); fabric colour: 7.5YR 6/4 (light brown); sand inclusions; medium-low firing temperature.

Description: conical bowl.

AbT.14.281.2 - Fig. 8.60

Dimensions: wall th.: 0.9 cm; base diam.: 22 cm; base th.: 1.2 cm.

Clay: outer (slip?) and inner colour (self-slip?): 2.5Y 8/2 (pale brown); fabric colour: 2.5YR 6/6 (light red); sand inclusions; medium firing temperature.

Description: stemmed-dish base.

AbT.14.281.3 - Fig. 8.60

Dimensions: wall th.: 0.9 cm; base diam.: 14 cm; base th.: 1 cm.

Clay: outer colour: 2.5Y 8/3 (pale brown); inner and fabric colour: 5YR 6/4 (light reddish brown); sand inclusions; medium firing temperature.

Description: ring base.

AbT.14.281.4 - Fig. 8.60

Dimensions: wall th.: 0.6 cm; base diam.: 6.5 cm; base th.: 0.7 cm.

Clay: outer, inner and fabric colour: 5YR 6/4 (light reddish brown); sand inclusions; medium firing temperature.

Description: string-cut base jar.

Catalogue of US 287 Finds

Objects

AbT.14.107 - Fig. 8.60

Description: porous stone. One of the fragments seems to form a sort of flat base. Found near the north tannur, between it and the north-west wall.

Dimensions: 23x10x20 cm.

Pottery

AbT.14.287.1 - Fig. 8.60

Dimensions: rim diam.: 38 cm; rim th.: 1 cm; wall th.: 1.2 cm.

Clay: outer, inner and fabric colour: 5YR 7/4 (pink); sand inclusions; medium firing temperature.

Description: shallow plate (base partially preserved).

Catalogue of US 297 Finds

Pottery

AbT.14.297.1 - Fig. 8.61

Dimensions: rim diam.: 12.5 cm; rim th.: 0.7 cm; wall th.: 0.9 cm; base diam.: 5.2 cm; base th.: 1.5 cm; h.: 12 cm.

Clay: outer, inner and fabric colour: 2.5YR 6/6 (light red); sand inclusions; medium firing temperature.

Description: beaker.

AbT.14.297.2 - Fig. 8.61

Dimensions: rim diam.: 11.5 cm; rim th.: 0.6 cm; wall th.: 0.6 cm; base diam.: 5.5 cm; base th.: 0.8 cm; h.: 7.7 cm.

Clay: outer and inner colour: 7.5YR 8/2 (pinkish white); fabric colour: 5YR 5/4 (reddish brown); sand inclusions; medium firing temperature.

Description: conical bowl.

AbT.14.297.3 - Fig. 8.61

Dimensions: wall th.: 1 cm; base diam.: 6.5 cm; base th.: 1.8 cm.

Clay: outer colour: 10YR 8/3 (very pale brown); inner and fabric colour: 5YR 6/4 (light reddish brown); sand inclusions; medium-low firing temperature.

Description: cylinder base.

AbT.14.297.4 - Fig. 8.61

Dimensions: rim diam.: 25 cm; rim th.: 0.8 cm; wall th.: 0.9 cm.

Clay: outer, inner and fabric colour: 10YR 4/1 (dark grey); sand inclusions; medium firing temperature.

Description: plain rim jar.

AbT.14.297.5 - Fig. 8.61

Dimensions: rim diam.: 18 cm; rim th.: 0.7 cm; wall th.: 0.6 cm.

Clay: outer and inner colour: 2.5Y 8/2 (pale brown); fabric colour: 7.5YR 6/4 (light brown); sand inclusions; medium-high firing temperature.

Description: plain rim jar.

AbT.14.297.6 - Fig. 8.61

Dimensions: rim diam.: 10 cm; rim th.: 0.7 cm; wall th.: 0.6 cm.

Clay: outer, inner and fabric colour: 2.5Y 7/2 (light grey); sand inclusions; high firing temperature.

Description: plain rim jar with rounded shoulder.

AbT.14.297.7 - Fig. 8.61

Dimensions: rim diam.: 14 cm; rim th.: 0.6 cm; wall th.: 0.7 cm.

Clay: outer colour: 10YR 8/2 (very pale brown); inner and fabric colour: 5YR 6/4 (light reddish brown); sand inclusions; medium firing temperature.

Description: plain rim jar.

AbT.14.297.8 - Fig. 8.61

Dimensions: rim diam.: 14 cm; rim th.: 0.9 cm; wall th.: 0.6 cm.

Clay: outer and inner colour: 7.5YR 8/3 (pink); fabric colour: 5YR 6/6 (reddish yellow); sand inclusions; medium firing temperature.

Description: double-ridged rim jar.

AbT.14.297.9 - Fig. 8.61

Dimensions: rim diam.: 52 (?) cm; rim th.: 1.8 cm; wall th.: 1.6 cm; base diam.: 50 cm; base th.: 1.7 cm; h.: 10.4 cm.

Clay: outer, inner and fabric colour: 10YR 8/3 (very pale brown); sand and vegetal inclusions; high firing temperature.

Description: tray (probably same of AbT.14.297.10).

AbT.14.297.10 - Fig. 8.61

Dimensions: rim diam.: 40 cm; rim th.: 1.4 cm; wall th.: 2 cm.

Clay: outer and fabric colour: 5Y 8/2 (pale yellow); inner colour: 2.5Y 8/2 (pale brown); sand and vegetal inclusions; high firing temperature.

Description: tray (probably same of AbT.14.297.9).

Catalogue of US 382 Finds

Objects

AbT.15.97 - Fig. 8.59

Description: copper alloy fragment.

Dimensions: 1x3.2x0.7 cm.

AbT.15.98 - Fig. 8.59

Description: grindstone fragment.

Dimensions: 5.2x1.3x5.5 cm.

Pottery

AbT.15.382.1 - Fig. 8.62

Dimensions: base diam.: 12.6 cm; base th.: 1.5 cm.

Clay: outer colour: 7.5YR 6/3 (light brown); inner and fabric colour: 5YR 5/6 (yellowish red); sand inclusions; medium-low firing temperature.

Description: ring base.

AbT.15.382.2 - Fig. 8.62

Dimensions: rim diam.: 18 cm; rim th.: 2.1 cm; wall th.: 1.3 cm.

Clay: outer and inner colour: 2.5Y 7/3 (pale brown); fabric colour: 5YR 6/3 (light reddish brown); sand inclusions; medium firing temperature.

Description: stemmed-dish bowl rim with notched decoration and wavy incisions on the top.

AbT.15.382.3 - Fig. 8.62

Dimensions: base diam.: 15 cm; base th.: 0.7 cm.

Clay: outer and inner colour: 10YR 7/2 (light grey); fabric colour: 5YR 5/4 (reddish brown); sand inclusions; medium firing temperature.

Description: ring base.

AbT.15.382.4 - Fig. 8.62

Dimensions: base diam.: 16 cm; base th.: 1 cm.

Clay: outer and inner colour: 5YR 5/4 (reddish brown); fabric colour: 7.5YR 6/3 (light brown); sand inclusions; medium-low firing temperature.

Description: ring base.

AbT.15.382.5 - Fig. 8.62

Dimensions: rim diam.: 16 cm; rim th.: 1.5 cm; wall th.: 1.5 cm; base diam.: 30 cm; base th.: 1.2 cm; h.: 11.5 cm.

Clay: outer colour: 2.5Y 6/3 (light yellowish brown); inner and fabric colour: 5Y 6/3 (pale olive); sand inclusions; medium firing temperature.

Description: tray.

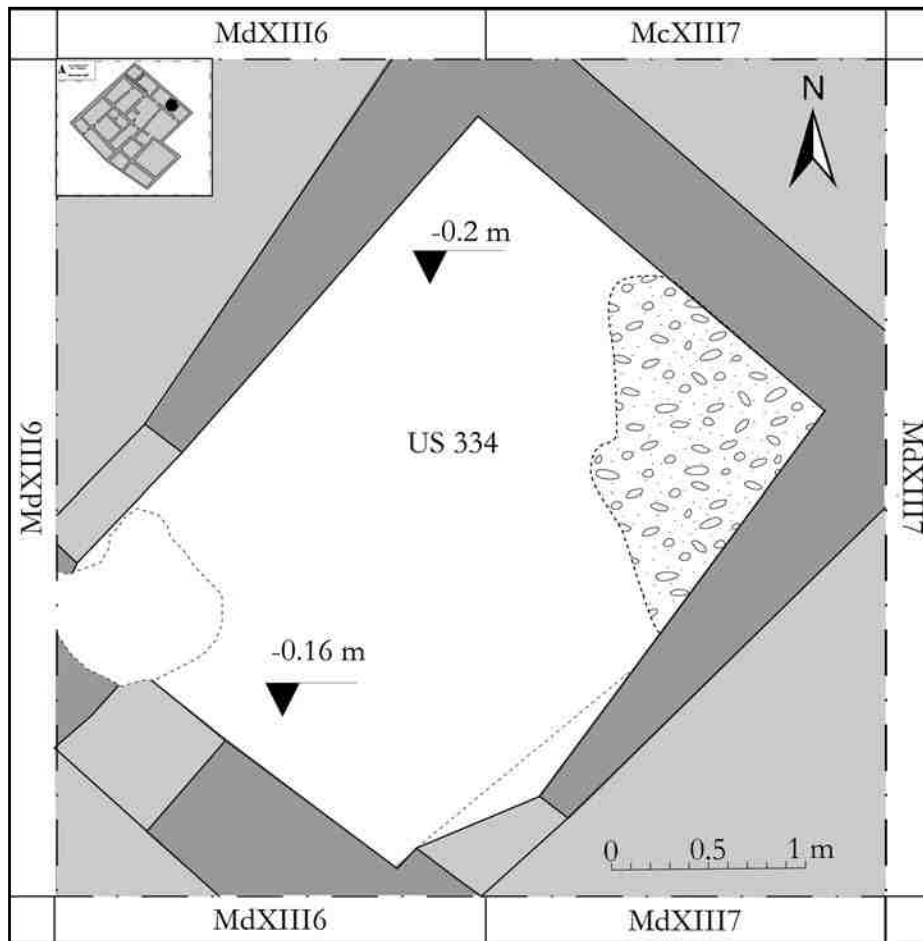

Fig. 8.63 Room 12 plan.

8.12 ROOM 12 [LR]

Room 12 (Fig. 8.63) was filled by a quite compact pale brown lumpy silty-clay soil (US 331) with mud-brick fragments inside. A mud-brick wall collapse was identified in the north-east angle of the Room. The lower section of the layer was softer. In the south-western part the stratum and the walls were cut by a shallow pit (US 330; see § 7.5.1). The housing surface (US 334) was sampled for heavy residue analysis.

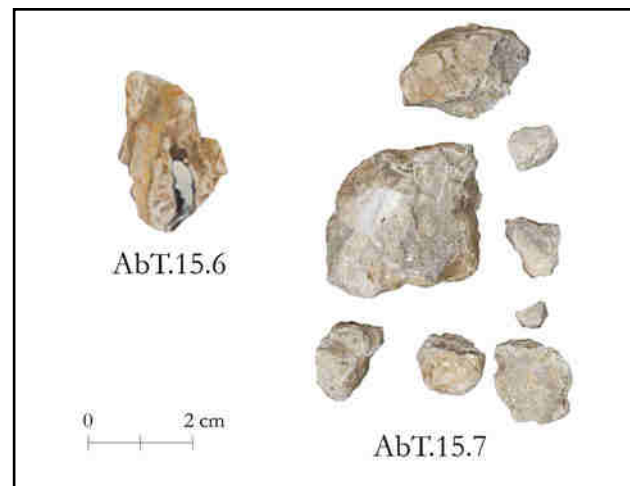

Fig. 8.64 US 331 objects.

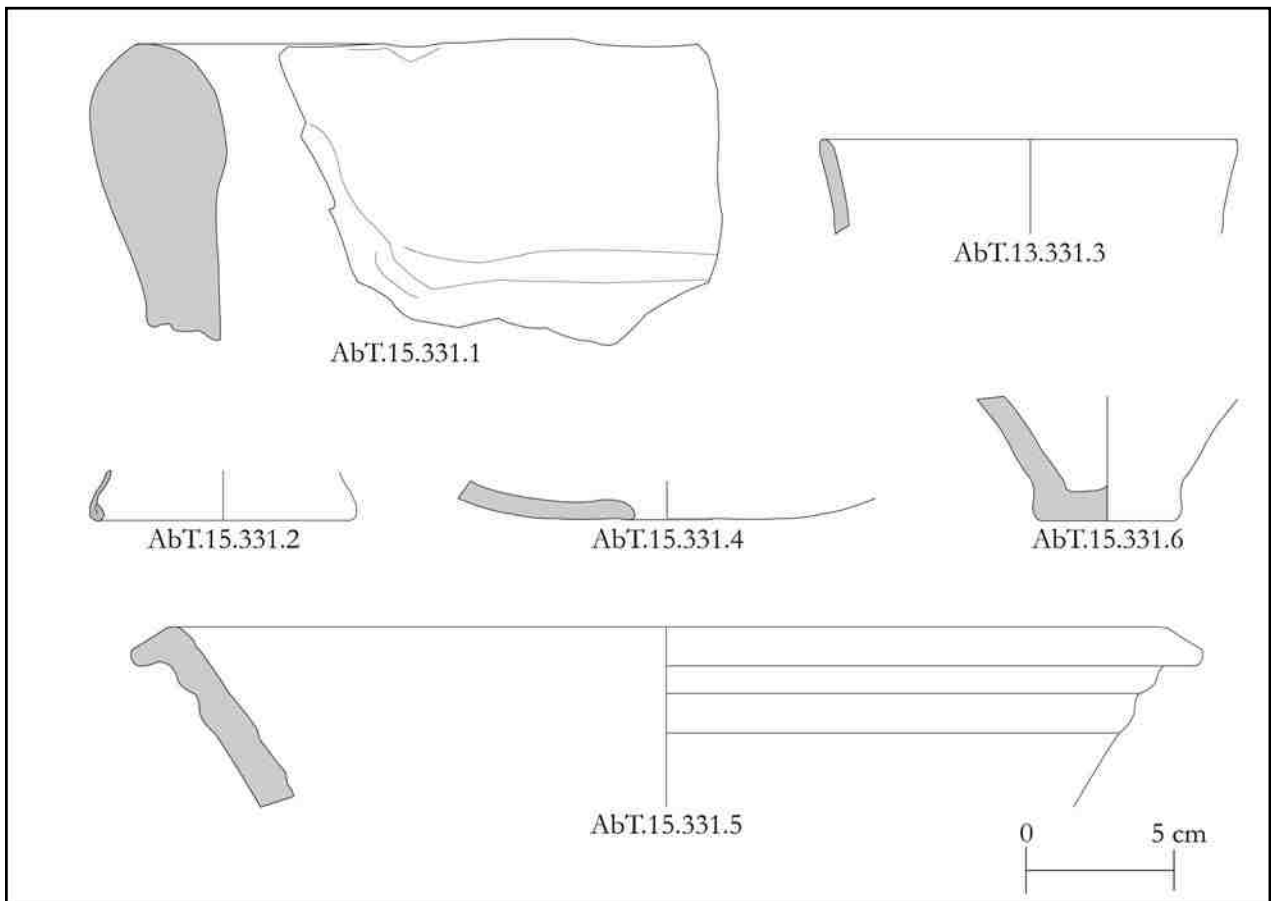

Fig. 8.65 US 331 pottery.

Catalogue of US 331 Finds

Objects

AbT.15.6 - Fig. 8.64

Description: chert flake.

Dimensions: 2.3x3.7x0.7 cm.

(black); sand inclusions; medium-high firing temperature.

Description: folded rim of a lid (?).

inclusions; medium-high firing temperature.

Description: triangular rim bowl.

AbT.15.7 - Fig. 8.64

Description: various chert fragments.

Dimensions: 2.8x2.9x2.7x2 cm.

AbT.15.331.3 - Fig. 8.65

Dimensions: rim diam.: 13.5 cm; rim th.: 0.6 cm; wall th.: 0.6 cm.

Clay: outer and inner colour: 5Y 8/3 (pale yellow); fabric colour: 10YR 6/4 (light yellowish brown); sand inclusions; medium-high firing temperature.

Description: plain rim jar.

AbT.15.331.6 - Fig. 8.65

Dimensions: wall th.: 0.6 cm; base diam.: 4.5 cm; base th.: 0.8 cm.

Clay: outer and inner colour: 2.5Y 7/3 (pale brown); fabric colour: 5YR 5/4 (reddish brown); sand inclusions; medium-high firing temperature.

Description: conical bowl base.

Pottery

AbT.15.331.1 - Fig. 8.65

Dimensions: rim diam.: n.d. cm; rim th.: 4.5 cm; wall th.: 1.6 cm.

Clay: outer and inner colour: 2.5Y 8/2 (pale brown); fabric colour: 5YR 6/6 (reddish yellow); vegetal and sand inclusions; low firing temperature.

Description: band rim of a vat, covered by bitumen (both outside and inside).

AbT.15.331.4 - Fig. 8.65

Dimensions: rim diam.: 7 cm; rim th.: 0.7 cm; wall th.: 0.7 cm.

Clay: outer, inner and fabric colour: 2.5Y 8/2 (pale brown); sand inclusions; medium-high firing temperature.

Description: hole of a strainer (?).

AbT.15.331.2 - Fig. 8.65

Dimensions: rim diam.: 8 cm; rim th.: 0.6 cm; wall th.: 0.2 cm.

Clay: outer and inner colour: 2.5Y 7/3 (pale brown); fabric colour: 2.5Y 2.5/1

AbT.15.331.5 - Fig. 8.65

Dimensions: base diam.: 32 cm; base th.: 1.2 cm.

Clay: outer, inner and fabric colour: 2.5YR 5/4 (reddish brown); sand

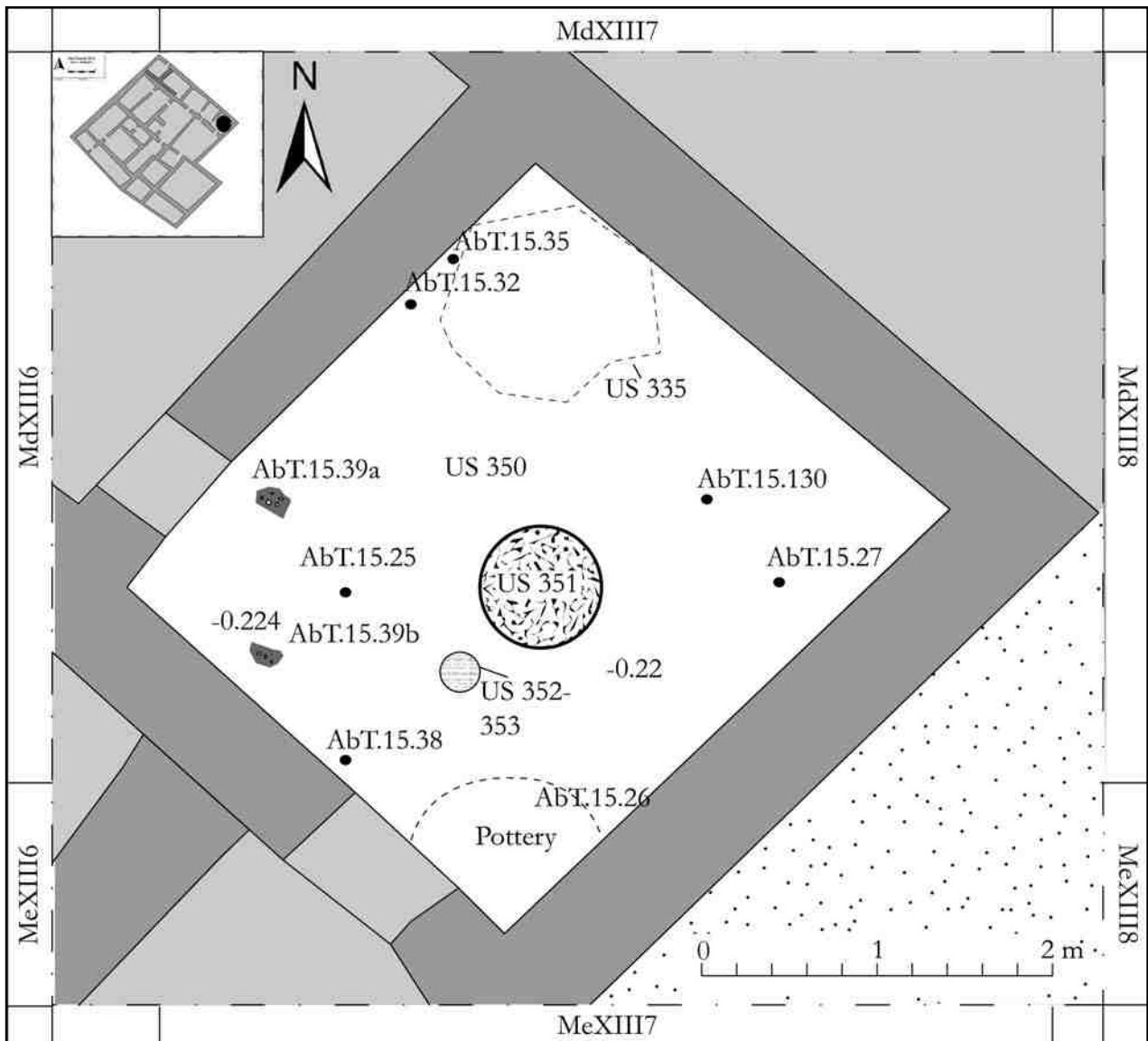

Fig. 8.66 Room 13 plan.

8.13 ROOM 13 [LR]

Room 13 was filled by US 337=345,¹⁸ a silty clay stratum hardened by salt. A concentration of pottery was found in the southern corner of the Room.¹⁹ US 337=345 was cut by pit US 335 (see § 7.4.2). The ground surface (US 350) was sampled for heavy residue analysis. The Room was characterized by the presence of a fireplace (US 351) and a big post-hole (US 352-353). The

finds include several chert blades, two stone vessel fragments and two pieces of chariot models.

¹⁸ A second layer was distinguished on the basis of the consistence (probably the difference was due to post-depositional agents).

¹⁹ Also in this case mostly drinking vessels, jars, and some fragments of big coarse container were collected. The location of the pottery in this part of the Room seems to be due to the flowing of water toward the door.

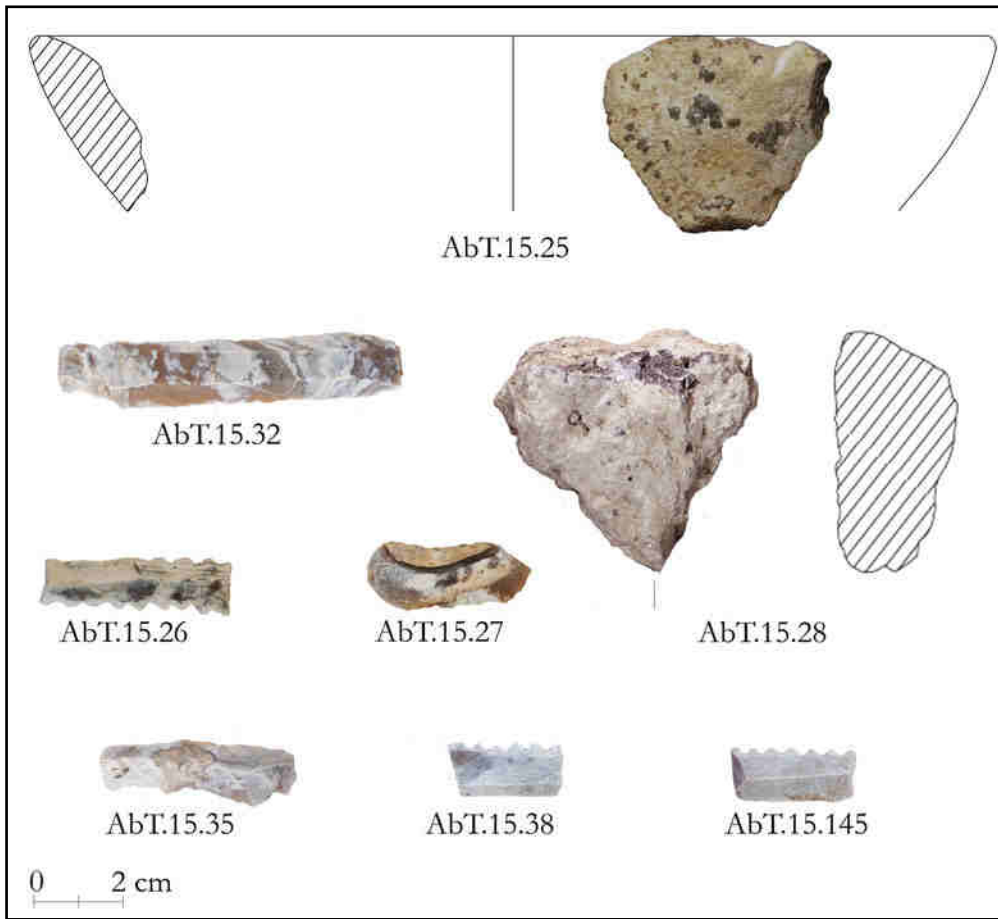

Fig. 8.67 US 337 objects.

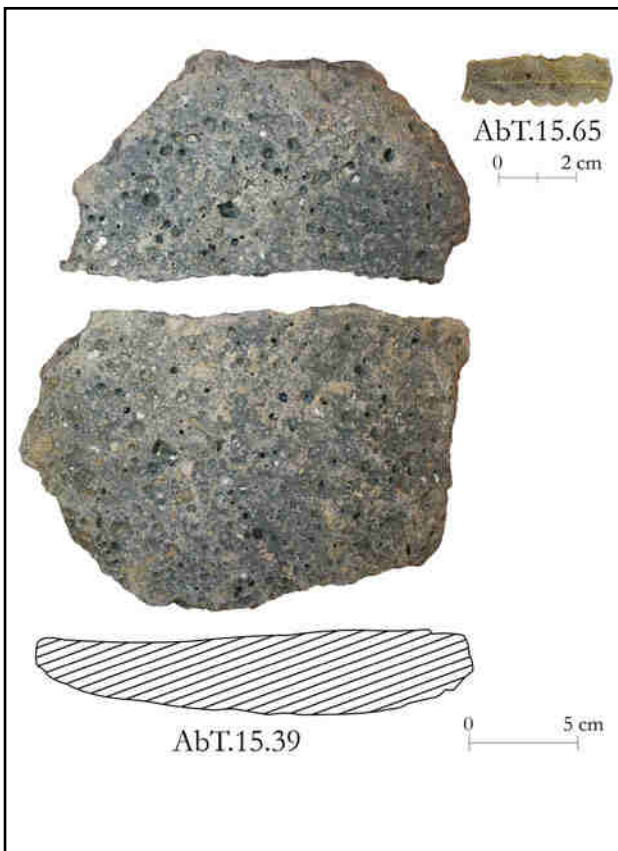

Fig. 8.68 US 345 objects.

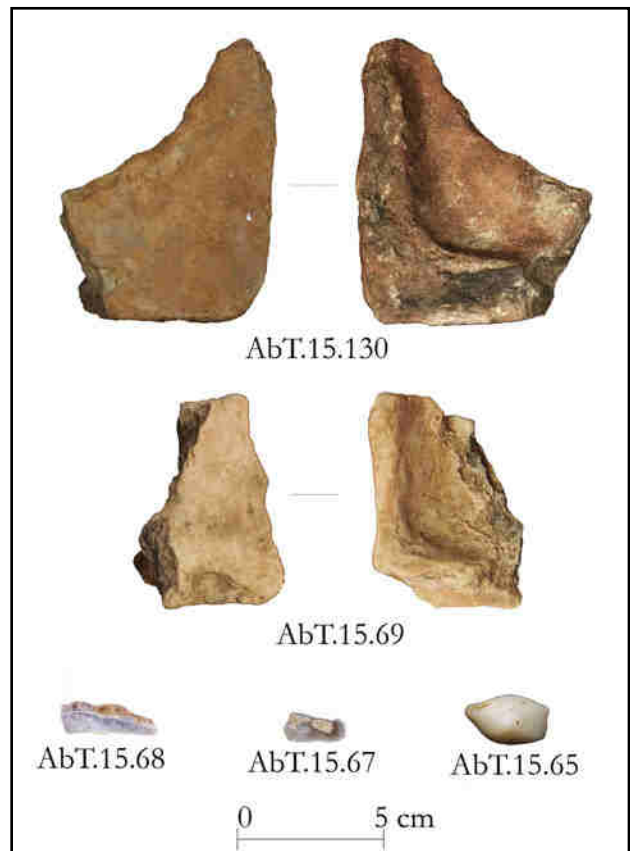

Fig. 8.69 US 350 objects.

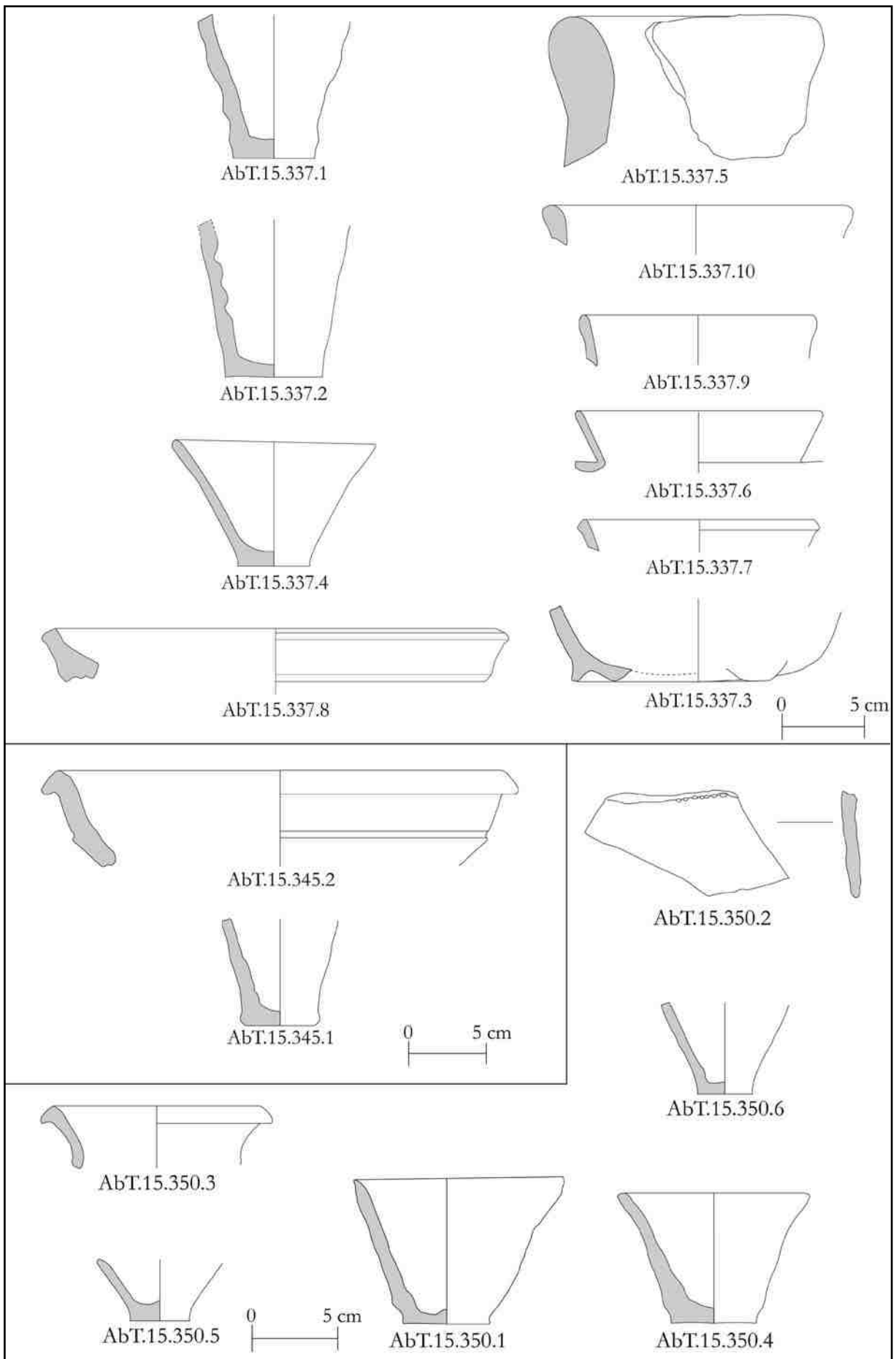

Fig. 8.70 US 337, US 345 and US 350 pottery.

Catalogue of US 337 Finds

*Objects***AbT.15.145 - Fig. 8.67**

Description: chert sickle element.
Dimensions: 1.3x2.9x0.5 cm.

AbT.15.25 - Fig. 8.67

Description: limestone vessel fragment with rim. Some abrasions and striations are visible on both the inside and the outside, possibly technological but could also be due to the nature of the raw material which is very brittle. [SC]
Dimensions: 5.2x4.5x1.4 cm.

AbT.15.26 - Fig. 8.67

Description: chert sickle element.
Dimensions: 1.3x4.5x0.4 cm.

AbT.15.27 - Fig. 8.67

Description: chert blade.
Dimensions: 1.4x3.6x0.4 cm.

AbT.15.28 - Fig. 8.67

Description: grindstone fragment.
Dimensions: 5.6x4.6x5.4x2.6 cm.

AbT.15.32 - Fig. 8.67

Description: chert blade.
Dimensions: 1.5x8x0.3 cm

AbT.15.35 - Fig. 8.67

Description: chert blade.
Dimensions: 1.1x4.4x0.6 cm.

AbT.15.38 - Fig. 8.67

Description: chert sickle element.
Dimensions: 1.3x2.7x0.2 cm

*Pottery***AbT.15.337.1 - Fig. 8.70**

Dimensions: wall th.: 0.6 cm; base diam.: 5 cm; base th.: 1.7 cm.
Clay: outer, inner and fabric colour: 5YR 5/6 (yellowish red); sand inclusions; medium firing temperature.
Description: beaker base.

AbT.15.337.2 - Fig. 8.70

Dimensions: wall th.: 1 cm; base diam.: 5.7 cm; base th.: 2 cm.
Clay: outer, inner and fabric colour: 5YR 5/4 (reddish brown); sand inclusions; medium firing temperature.
Description: beaker base.

AbT.15.337.3 - Fig. 8.70

Dimensions: wall th.: 0.7 cm; base diam.: 15 cm; base th.: 0.8 cm.

Clay: outer colour: 10YR 8/3 (very pale brown); inner and fabric colour: 5YR 6/4 (light reddish brown); sand inclusions; medium-high firing temperature.

Description: convex base with three feet.

AbT.15.337.4 - Fig. 8.70

Dimensions: rim diam.: 15.5 cm; rim th.: 0.7 cm; wall th.: 0.7 cm; base diam.: 5 cm; base th.: 0.8 cm; h.: 7.5 cm.

Clay: outer and inner colour: 5YR 6/6 (reddish yellow); fabric colour: 10YR 6/4 (light yellowish brown); sand inclusions; medium-low firing temperature.

Description: conical bowl.

AbT.15.337.5 - Fig. 8.70

Dimensions: rim diam.: n.d.; rim th.: 3.9 cm; wall th.: 2.6 cm.

Clay: outer, inner and fabric colour: 10YR 6/3 (pale brown); sand and vegetal inclusions; medium firing temperature.

Description: vat rim.

AbT.15.337.6 - Fig. 8.70

Dimensions: rim diam.: 15 cm; rim th.: 0.6 cm; wall th.: 0.7 cm.

Clay: outer and inner colour: 2.5Y 6/2 (light greyish brown); fabric colour: 10YR 6/6 (brownish yellow); sand inclusions; medium firing temperature.

Description: plain rim jar.

AbT.15.337.7 - Fig. 8.70

Dimensions: rim diam.: 14 cm; rim th.: 0.8 cm; wall th.: 0.6 cm.

Clay: outer and inner colour: 10YR 8/3 (very pale brown); fabric colour: 7.5YR 6/4 (light brown); sand inclusions; medium firing temperature.

Description: almost plain rim jar.

AbT.15.337.8 - Fig. 8.70

Dimensions: rim diam.: 27 cm; rim th.: 1.2 cm; wall th.: 1.3 cm.

Clay: outer colour: 10YR 7/3 (very pale brown); inner and fabric colour: 7.5YR 7/4 (pink); sand inclusions; medium firing temperature.

Description: shallow bowl.

AbT.15.337.9 - Fig. 8.70

Dimensions: rim diam.: 14 cm; rim th.: 0.9 cm; wall th.: 0.9 cm.

Clay: outer colour: 2.5Y 8/3 (pale brown); inner and fabric colour: 7.5YR 6/4 (light brown); sand inclusions; medium firing temperature.

Description: plain rim jar.

AbT.15.337.10 - Fig. 8.70

Dimensions: rim diam.: 18 cm; rim th.: 1.2 cm.

Clay: outer, inner and fabric colour: 5YR 5/4 (reddish brown); sand inclusions; medium-low firing temperature.

Description: plain rim jar.

Catalogue of US 345 Finds

*Objects***AbT.15.39 - Fig. 8.68**

Description: grindstone (two pieces).
Dimensions: 14x3.5x20 cm.

AbT.15.65 - Fig. 8.68

Description: chert sickle element.
Dimensions: 1.5x4x0.3 cm.

*Pottery***AbT.15.345.1 - Fig. 8.70**

Dimensions: wall th.: 0.8 cm; base diam.: 4.5 cm; base th.: 1 cm.

Clay: outer, inner and fabric colour: 5YR 6/4 (light reddish brown); sand inclusions; low firing temperature.

Description: beaker base.

AbT.15.345.2 - Fig. 8.70

Dimensions: rim diam.: 30 cm; rim th.: 2 cm; wall th.: 1.5 cm.

Clay: outer, inner and fabric colour: 5YR 6/4 (light reddish brown); sand inclusions; medium firing temperature.

Description: triangular rim bowl.

Catalogue of US 350 Finds

*Objects***AbT.15.130 - Fig. 8.69**

Description: fragment of a pottery chariot model. Embedded in the pavement (found during flotation for HRA).

Dimensions: 7x9x4.5 cm.

AbT.15.65 - Fig. 8.69

Description: small river pebble. Possibly used as small polisher considering that one face is very flattened whereas the others are natural. [SC]

Dimensions: 1.6x2.7x1.4 cm; weight 8 gr.

AbT.15.67 - Fig. 8.69

Description: chert blade.

Dimensions: 11x2.2x0.4 cm.

AbT.15.68 - Fig. 8.69

Description: chert blade.

Dimensions: 1.2x3.4x0.4 cm.

AbT.15.69 - Fig. 8.69

Description: clay chariot fragment.

Dimensions: 4.9x5.2x6.1x3.7 cm.

*Pottery***AbT.15.350.1 - Fig. 8.70**

Dimensions: rim diam.: 12.2 cm; rim th.: 0.5 cm; wall th.: 0.7 cm; base diam.: 4.9 cm; base th.: 0.8 cm.

Clay: outer and inner colour: 2.5YR 6/6 (light red); fabric colour: 5YR 5/6 (yellowish red); sand inclusions; low firing temperature.

Description: conical bowl.

AbT.15.350.2 - Fig. 8.70

Dimensions: wall th.: 0.7 cm.

Clay: outer colour: 2.5Y 8/2 (pale brown); inner colour and fabric colour: 2.5Y 7/2 (light grey); sand inclusions; medium-high firing temperature.

Description: wall fragment decorated with seven almost oval incisions.

AbT.15.350.3 - Fig. 8.70

Dimensions: rim diam.: 12 cm; rim th.: 1 cm; wall th.: 0.7 cm.

Clay: outer, inner and fabric colour: 5YR 5/6 (yellowish red); sand inclusions; medium-low firing temperature.

Description: triangular rim jar.

AbT.15.350.4 - Fig. 8.70

Dimensions: rim diam.: 11 cm; rim th.: 0.6 cm; wall th.: 0.9 cm; base diam.: 4.9 cm; base th.: 0.9 cm; h.: 7.5 cm.

Clay: outer, inner and fabric colour: 5YR 6/6 (reddish yellow); sand inclusions; medium-low firing temperature.

Description: conical bowl.

AbT.15.350.5 - Fig. 8.70

Dimensions: base diam.: 3.5 cm; base th.: 1.2 cm.

Clay: outer, inner and fabric colour: 5YR 6/6 (reddish yellow); sand inclusions; medium-low firing temperature.

Description: conical bowl base.

AbT.15.350.6 - Fig. 8.70

Dimensions: wall th.: 0.6 cm; base diam.: 3.2 cm; base th.: 0.7 cm.

Clay: outer and inner colour: 10YR 7/4 (very pale brown); fabric colour: 5YR 6/6 (reddish yellow); sand inclusions; medium firing temperature.

Description: beaker base.

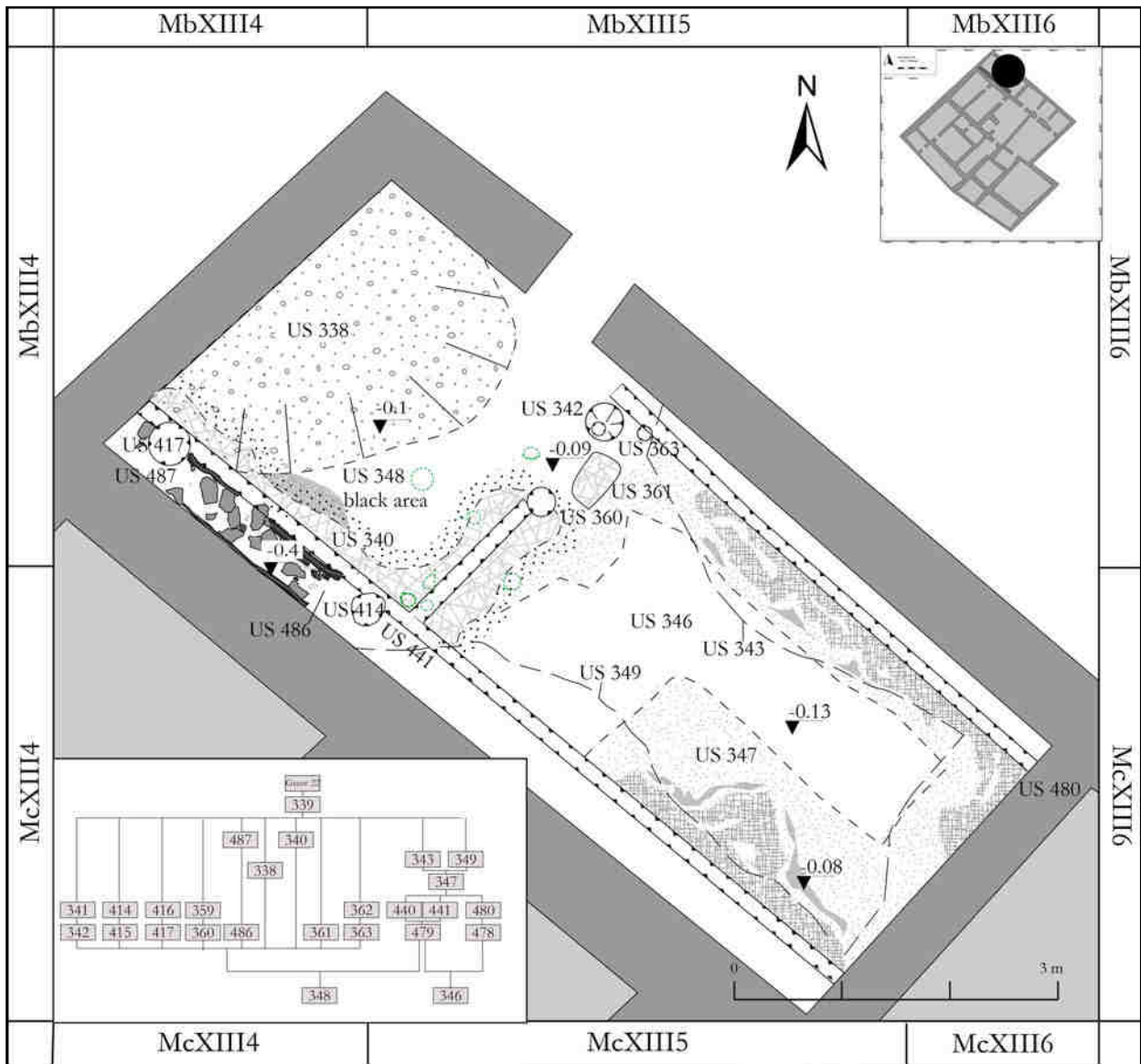

Fig. 8.71 Room 14-15 plan.

8.14 ROOM 14-15 [LR]

The situation of these two rooms (Fig. 8.71) was particularly interesting: the researches and analysis on the materials here recovered are still ongoing and thus a sketched picture of the Room will be presented, while an extensive study will be published in the near future. A movable reed structure divided the space in two parts and thus we decided to assign two different room numbers, though the context should be considered as a whole.

The strong erosion in this part of the building and the later activities on the spot (see Grave 22 at § 7.3.1), left very little preserved of the last phase of the Building.

However, Room 14-15 was probably destroyed by fire and not gradually abandoned, thus leaving on the floor clearer evidences of occupation than in other spaces of the Building.

As stated previously, Grave 22 was excavated in a clay-silty layer composed mainly by the collapse of the mud and reed structure US 339, hardened by fire²⁰ and extended apparently until the south-east limits of Room 15. After having excavated few centimetres, the subdivisions of the two spaces and the strata pertaining to the destruction of the Room

²⁰ Fragments of mud with reed impressions were found mainly scattered on the north-western section of the Room.

were identified.²¹ The structure was realized with reed panels sustained by four posts and partially set in the ground-surface inside a long and narrow foundation pit (cut US 479, with an elevation of -0.25 of the bottom; filling US 440+441). The reed panels and posts were probably partially covered (at least at their base) with clay: a huge quantity of clay lumps hardened by fire and with reed impressions were dispersed both inside US 339 and along the foundation pits (US 479). This kind of structure should be considered similar to those still attested in the Marshland, with posts made by reed bundles.²² The reed panels were linked to a sort of long firing structure (Fig. 8.72), probably vaulted, located along the south-west wall, partially dug in the pavement and with the cut (US 486; bottom at -0.4 m ca) revetted by the same kind of clay used for the realization of tannurs. Lots of collapsed and burnt mud-bricks, mixed to few pottery fragments and bones, were found in the filling of the structure (US 487).²³ The structure had an opening in the middle in correspondence of the darker area on the floor. It is unfortunately not clear if this kind of oven was cut in the pavement (US 348) during the occupation of the last phase of the Building or was a structure in use also in the earlier occupational phase of the space. Though the presence of similar cooking activities is attested also in the earlier phase of the space, the association of the firing structure with reed panels was a characteristic of phase 1 (no internal subdivision of the space was identified in the earlier phase 2).

The reed structure had an opening near the north-east wall, supported by the post holes US 341-342 and US 359-360. In front of the opening a rectangular concentration of burnt reeds was found (US 361) and interpreted as a door. A fourth post-hole US 362-363, probably related to the door mechanism, was found near US 359-360: these two holes had a different conformation than the others, being formed by a larger cut on the top

²¹ US 340 indicates the fragments of the reed impressions spread near the original position of the structure and US 487 refers to the collapse of the fire installation.

²² At least US 417 and US 360.

²³ US 487 was extensively documented with photo-documentation, 3D rendering and CAD representation before being excavated to under its base. All fire hardened mud-bricks, oven walls, bones, pottery fragments and one stone were individually collected.



Fig. 8.72 Room 14. Detail of the oven from north-west.

and a smaller and deeper circular depression on the bottom.

The occupation and use of the Room was characterized by the accumulation of clay and ashy soil (US 338), generated by the use of the pit-oven, sloping from the north-western wall toward the centre of the space. The US contained lots of animal bones and discarded pottery fragments (mainly drinking vessels), some of them showing burning traces.²⁴

Room 15 showed several collapse layers under US 339. US 343 and 349, mainly constituted of mud-brick fragments, covered US 347.²⁵ This stratum, located along the Room limits, was composed by burned reeds and areas reddened and hardened by fire. The pavement (US 346; elevation -0.13)

²⁴ 38 bases of conical bowls, 5 of beakers and 7 undetermined. Due to the extremely loose soil of US 338 we over-excavated the stratum, probably including in this way also some of the pottery fragments of the ashy soil filling Room 14-15.

²⁵ Some human bones (a perinatal individual) were found, probably pertaining to a not identified later intrusive grave.

was cut by the prosecution of US 479 (filling 440-441) and on the opposite side by US 478 (filling US 480).

The context discovered inside the two rooms and in particular the presence of the firing structure might lead to reconsider the pottery equipment belonging to Grave 22. (US 332). As said in § 7.3.1, the disposition of this part of the equipment, scattered south of the body, is due to post-depositional changes (flowing of the rainfall water etc.). Moreover, the position of the vessels along the reed-panels (in green at Fig. 8.71), the presence of a conical bowl AbT.15.332.6 and of a bottle

AbT.15.332.4 with bitumen, rises some doubts about the stratigraphic attribution of these vessels. However, the absence of burning traces, the cut clearly visible at the moment of the excavation of the grave, as well as the vessel positions over the remains of the collapse of the Room seem to confirm the attribution. However, the attribution of US 332 and its pottery to the later grave avoids the eventual contamination of the lower strata with later materials.

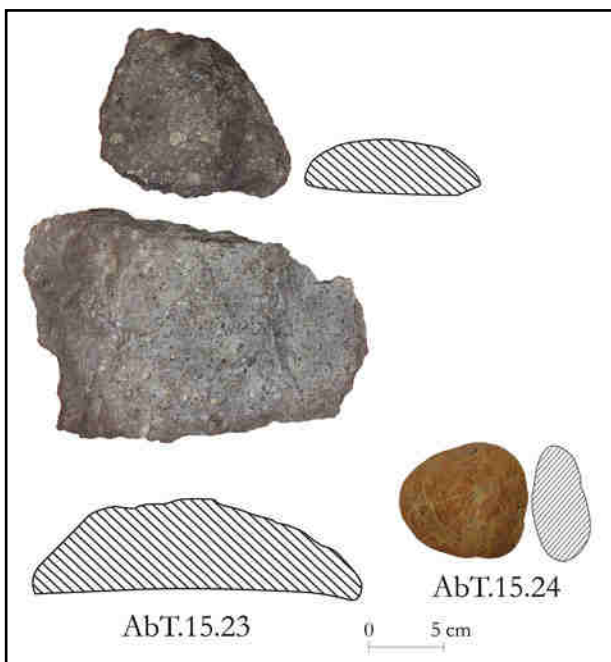

Fig. 8.73 US 339 objects.

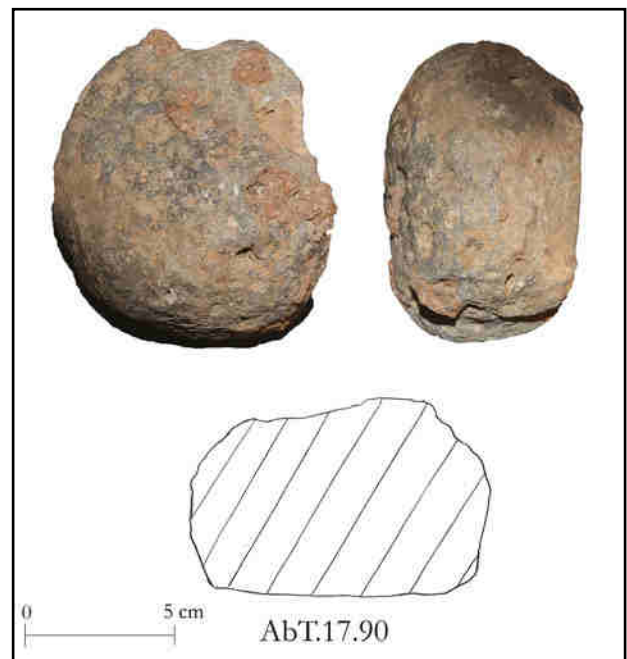

Fig. 8.74 US 487 objects.

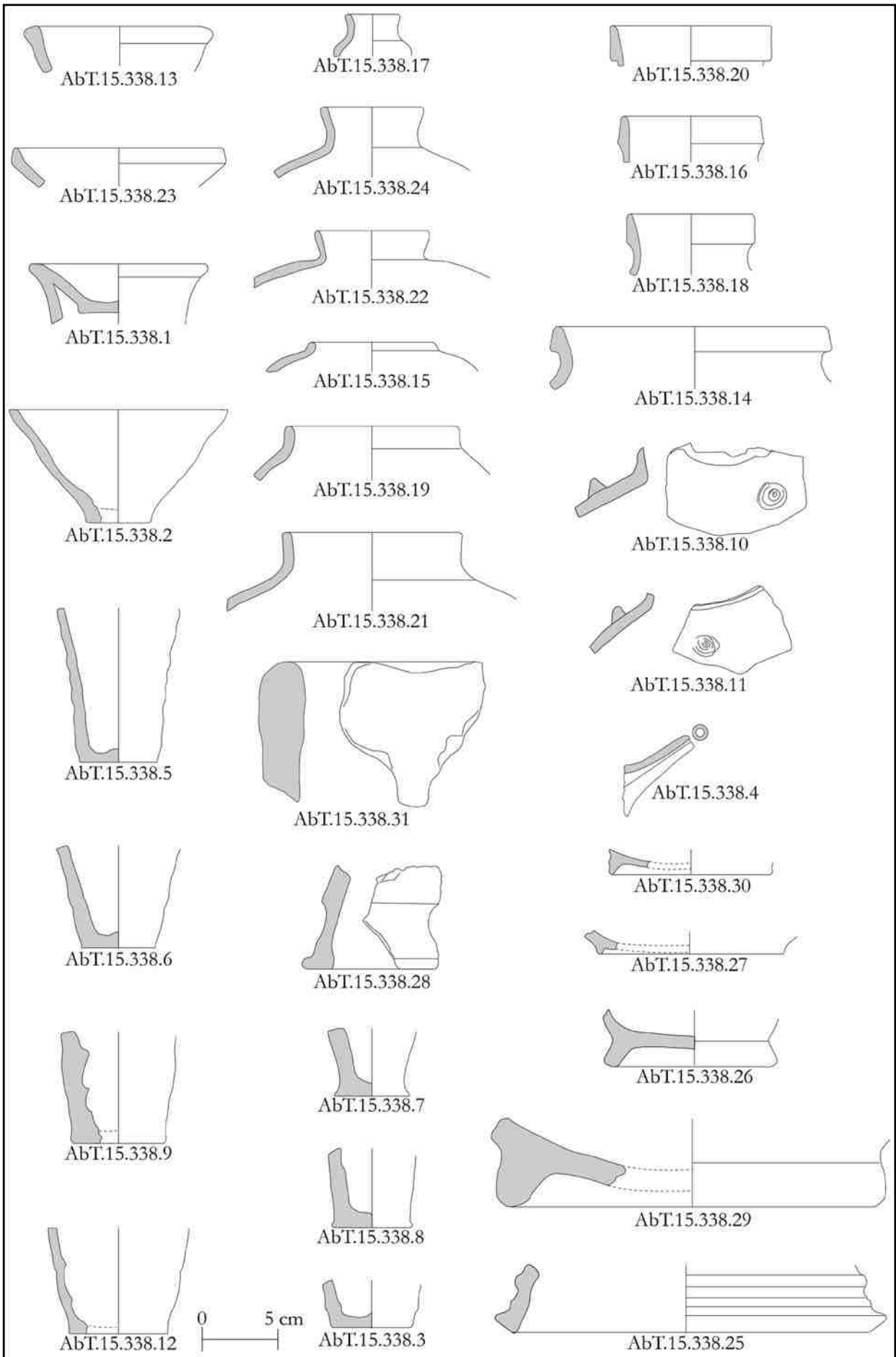

Fig. 8.75 US 338 pottery.

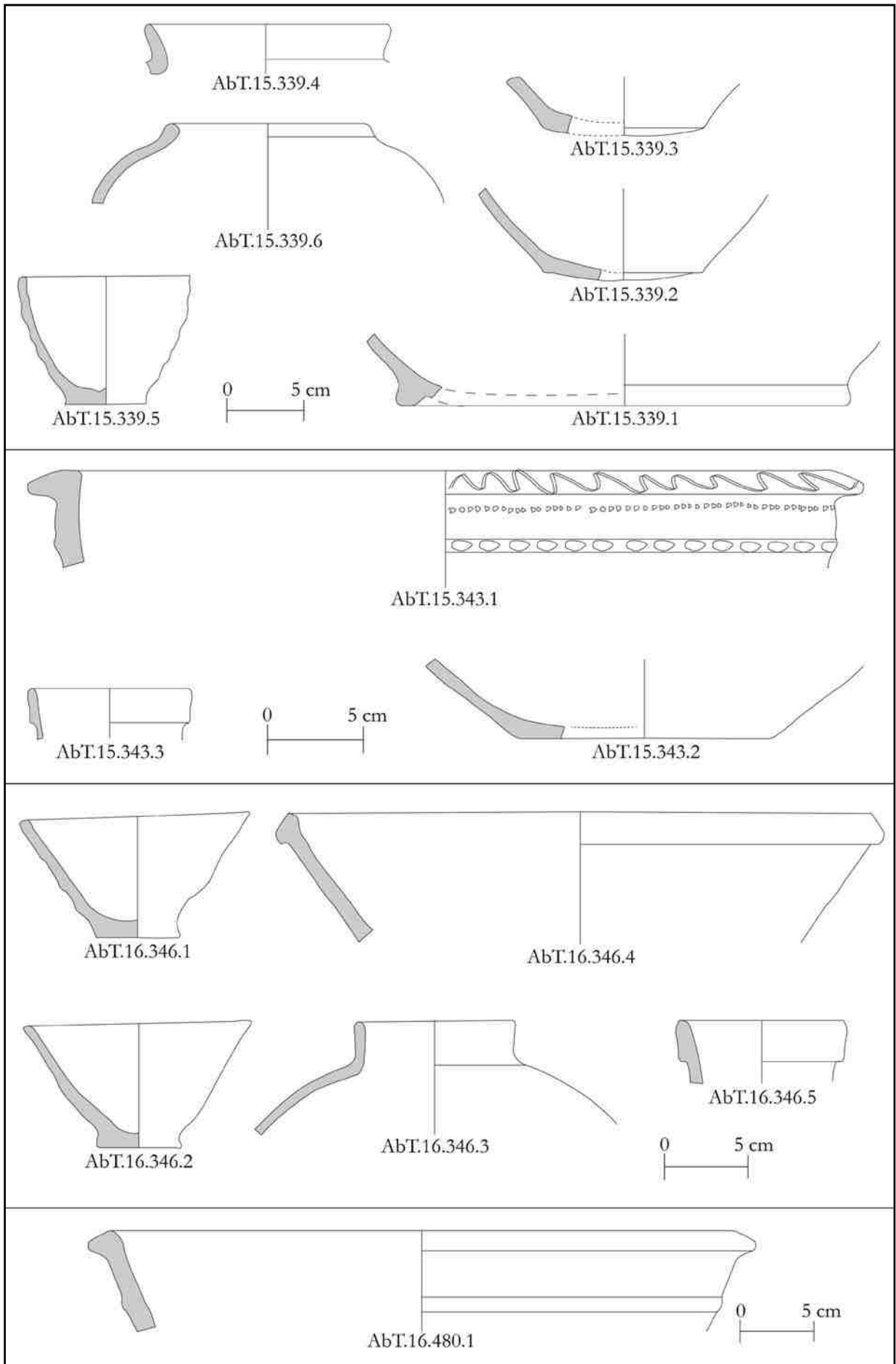

Fig. 8.76 US 339, US 343, US 346 and US 480 pottery.

Catalogue of US 338 Finds

*Pottery***AbT.15.338.1 - Fig. 8.75**

Dimensions: rim diam.: 12 cm; rim th.: 0.9 cm; wall th.: 0.7 cm; base diam.: 4 cm; base th.: 0.9 cm; h. 3 cm.

Clay: outer colour: 10YR 8/3 (very pale brown); inner and fabric colour: 5YR 6/6 (reddish yellow); sand inclusions; medium-low firing temperature.

Description: conical bowl attached to a stand.

AbT.15.338.2 - Fig. 8.75

Dimensions: rim diam.: 15 cm; rim th.: 0.7 cm; wall th.: 0.7 cm; base diam.: 4.5 cm; base th.: 1.4 cm; h.: 7.5 cm.

Clay: outer colour: 5YR 7/6 (reddish yellow); inner colour: 10YR 8/3 (very pale brown); fabric colour: 7.5YR 6/6 (reddish yellow); sand inclusions; medium-low firing temperature.

Description: conical bowl.

AbT.15.338.3 - Fig. 8.75

Dimensions: wall th.: 0.9 cm; base diam.: 5.3 cm; base th.: 1 cm.

Clay: outer, inner and fabric colour: 5YR 6/4 (light reddish brown); sand inclusions; low firing temperature.

Description: beaker base.

AbT.15.338.4 - Fig. 8.75

Dimensions: rim diam.: 1 cm; rim th.: 0.5 cm; wall th.: 0.8 cm.

Clay: outer colour: 10YR 8/3 (very pale brown); inner and fabric colour: 7.5YR 7/6 (reddish yellow); sand inclusions; medium firing temperature.

Description: spout.

AbT.15.338.5 - Fig. 8.75

Dimensions: wall th.: 0.7 cm; base diam.: 5 cm; base th.: 1.5 cm.

Clay: outer, inner and fabric colour: 5YR 6/4 (light reddish brown); sand inclusions; low firing temperature.

Description: beaker base.

AbT.15.338.6 - Fig. 8.75

Dimensions: wall th.: 0.8 cm; base diam.: 5 cm; base th.: 1 cm.

Clay: outer, inner and fabric colour: 2.5Y 8/2 (pale brown); sand inclusions; medium-high firing temperature.

Description: beaker base.

AbT.15.338.7 - Fig. 8.75

Dimensions: wall th.: 1 cm; base diam.: 5 cm; base th.: 1 cm.

Clay: outer, inner and fabric colour: 5YR 6/4 (light reddish brown); sand inclusions; medium-low firing temperature.

Description: beaker base.

AbT.15.338.8 - Fig. 8.75

Dimensions: wall th.: 0.8 cm; base diam.: 4.9 cm; base th.: 0.8 cm.

Clay: outer colour: 2.5Y 8/3 (pale brown); inner and fabric colour: 2.5Y 7/4 (pale brown); sand inclusions; medium-low firing temperature.

Description: beaker base.

AbT.15.338.9 - Fig. 8.75

Dimensions: base diam.: 9 cm; base th.: 1.2 cm.

Clay: outer colour: 10YR 8/3 (very pale brown); inner and fabric colour: 10YR 8/4 (very pale brown); sand inclusions; medium-low firing temperature.

Description: cylinder base.

AbT.15.338.10 - Fig. 8.75

Dimensions: wall th.: 1 cm.

Clay: outer colour (very eroded slip?): 7.5YR 8/3 (pink); inner and fabric colour: 5YR 5/4 (reddish brown); sand inclusions; medium firing temperature.

Description: jar wall with a knob.

AbT.15.338.11 - Fig. 8.75

Dimensions: wall th.: 1 cm.

Clay: outer, inner and fabric colour: 2.5Y 8/3 (pale brown); sand inclusions; medium firing temperature.

Description: jar wall with a knob.

AbT.15.338.12 - Fig. 8.73

Dimensions: base diam.: 3.5 cm; base th.: 0.8 cm.

Clay: outer and inner colour: 10YR 8/3 (very pale brown); fabric colour: 7.5YR 7/6 (reddish yellow); sand inclusions; medium firing temperature.

Description: cylinder/slowly wheel-Thrown beaker base.

AbT.15.338.13 - Fig. 8.75

Dimensions: rim diam.: 11 cm; rim th.: 1.3 cm; wall th.: 0.7 cm.

Clay: outer and inner colour: 2.5Y 8/3 (pale brown); fabric colour: 10YR 7/4 (very pale brown); sand inclusions; medium firing temperature.

Description: triangular rim (lid?).

AbT.15.338.14 - Fig. 8.75

Dimensions: rim diam.: 22 cm; rim th.: 1.7 cm; wall th.: 1.1 cm.

Clay: outer and inner colour: 10YR 7/4 (very pale brown); fabric colour: 7.5YR 7/6 (reddish yellow); sand inclusions; medium firing temperature.

Description: triangular rim jar.

AbT.15.338.15 - Fig. 8.75

Dimensions: rim diam.: 10 cm; rim th.: 0.7 cm; wall th.: 0.8 cm.

Clay: outer and inner colour (self-slip): 10YR 7/6 (yellow); fabric colour: 5YR 6/6 (reddish yellow); sand inclusions; medium firing temperature.

Description: plain rim jar.

AbT.15.338.16 - Fig. 8.75

Dimensions: rim diam.: 10 cm; rim th.: 0.8 cm; wall th.: 0.6 cm.

Clay: outer, inner and fabric colour: 2.5Y 7/3 (pale brown); sand inclusions; medium firing temperature.

Description: band rim jar.

AbT.15.338.17 - Fig. 8.75

Dimensions: rim diam.: 6 cm; rim th.: 0.6 cm; wall th.: 0.7 cm.

Clay: outer, inner and fabric colour: 5YR 6/6 (reddish yellow); sand inclusions; medium-low firing temperature.

Description: miniaturistic plain rim jar.

AbT.15.338.18 - Fig. 8.75

Dimensions: rim diam.: 10 cm; rim th.: 0.7 cm; wall th.: 0.7 cm.

Clay: outer and inner colour: 5Y 8/3 (pale yellow); fabric colour: 5Y 7/2 (light grey); sand inclusions; medium-high firing temperature.

Description: band rim jar.

AbT.15.338.19 - Fig. 8.75

Dimensions: rim diam.: 14 cm; rim th.: 0.8 cm; wall th.: 0.8 cm.

Clay: outer and inner colour: 7.5YR 7/4 (pink); fabric colour: 5YR 6/4 (light reddish brown); sand inclusions; medium-low firing temperature.

Description: plain rim jar.

AbT.15.338.20 - Fig. 8.75

Dimensions: rim diam.: 13 cm; rim th.: 0.8 cm; wall th.: 0.6 cm.

Clay: outer colour: 10YR 8/3 (very pale brown); inner colour: 7.5YR 6/6 (reddish yellow); fabric colour: 5YR

5/4 (reddish brown); sand inclusions; medium firing temperature.
Description: band rim jar.

AbT.15.338.21 - Fig. 8.75

Dimensions: rim diam.: 14 cm; rim th.: 0.9 cm; wall th.: 9 cm.
Clay: outer colour: 10YR 7/4 (very pale brown); inner colour: 5YR 6/6 (reddish yellow); fabric colour: 10YR 6/4 (light yellowish brown); sand inclusions; medium-low firing temperature.
Description: plain rim jar.

AbT.15.338.22 - Fig. 8.75

Dimensions: rim diam.: 9 cm; rim th.: 0.6 cm; wall th.: 0.8 cm.
Clay: outer and inner colour: 2.5Y 8/3 (pale brown); fabric colour: 10YR 7/4 (very pale brown); sand inclusions; medium-high firing temperature.
Description: plain rim jar.

AbT.15.338.23 - Fig. 8.75

Dimensions: rim diam.: 14 cm; rim th.: 0.8 cm; wall th.: 0.6 cm.
Clay: outer, inner and fabric colour: 5YR 6/6 (reddish yellow); sand inclusions; medium-low firing temperature.
Description: lid(?).

AbT.15.338.24 - Fig. 8.75

Dimensions: rim diam.: 7 cm; rim th.: 0.7 cm; wall th.: 0.7 cm.
Clay: outer and inner colour: 2.5Y 8/3 (pale brown); fabric colour: 10YR 7/4 (very pale brown); sand inclusions; medium-high firing temperature.
Description: plain rim jar.

AbT.15.338.25 - Fig. 8.75

Dimensions: rim diam.: 24 cm; rim th.: 2 cm; wall th.: 1.2 cm.
Clay: outer and inner colour: 2.5Y 8/3 (pale brown); fabric colour: 7.5YR 7/6 (reddish yellow); sand inclusions; medium-high firing temperature.
Description: stemmed-dish base.

AbT.15.338.26 - Fig. 8.75

Dimensions: wall th.: 1 cm; base diam.: 13 cm; base th.: 1.5 cm.
Clay: outer and inner colour: 2.5Y 8/3 (pale brown); fabric colour: 7.5YR 6/3 (light brown); sand inclusions; medium firing temperature.
Description: ring base.

AbT.15.338.27 - Fig. 8.75

Dimensions: wall th.: 1 cm; base diam.: 16 cm; base th.: 1 cm.
Clay: outer and inner colour: 2.5Y 8/3 (pale brown); fabric colour: 7.5YR 6/4 (light brown); sand inclusions; medium-low firing temperature.
Description: ring base.

AbT.15.338.28 - Fig. 8.75

Dimensions: wall th.: 1.2 cm; base th.: 2 cm.
Clay: outer, inner and fabric colour: 5YR 6/4 (reddish brown); sand inclusions; medium-low firing temperature.
Description: stemmed-dish base.

AbT.15.338.29 - Fig. 8.75

Dimensions: wall th.: 2.1 cm; base th.: 3.7 cm; base diam.: 30(?) cm.
Clay: outer, inner and fabric colour: 7.5YR 7/3 (pink); sand and vegetal inclusions; low firing temperature.
Description: ring base.

AbT.15.338.30 - Fig. 8.75

Dimensions: base diam.: 14 cm; base th.: 0.9 cm.
Clay: outer colour: 10YR 8/3 (very pale brown); inner and fabric colour: 5YR 7/4 (pink); sand inclusions; medium-low firing temperature.
Description: ring base.

AbT.15.338.31 - Fig. 8.75

Dimensions: rim diam.: n.d. cm; rim th.: 3 cm; wall th.: 3.7 cm; base diam.: 5 cm; base th.: 1.2 cm; h.: 13.1 cm.
Clay: outer, inner and fabric colour: 2.5Y 7/2 (light grey); sand and vegetal inclusions; medium-high firing temperature.
Description: a big jar/vat plain rim.

Catalogue of US 339 finds

Objects

AbT.15.23 - Fig. 8.73

Description: grindstone fragment (2 pieces).
Dimensions: 16x22x6.5 cm (larger fragment); 15x12x5.5 cm.

AbT.15.24 - Fig. 8.74

Description: unknown raw material. Burnt pestle. Unlike others, it shows very clear pounding traces, on the main functional area, but very little other

functions were carried out with it. Only one surface shows a slight levelling, maybe due to use as polisher, but the quality of the raw material makes interpretation difficult. [SC]
Dimensions: 8.5x7.5x5.3 cm.

Pottery

AbT.15.339.1 - Fig. 8.76

Dimensions: walls th.: 0.8 cm; base diam.: 28 cm; base th.: 1 cm.
Clay: outer, inner and fabric colour: 2.5Y 8/3 (pale brown); sand and vegetal inclusions; medium firing temperature.
Description: ring base.

AbT.15.339.2 - Fig. 8.76

Dimensions: base diam.: 10 cm; base th.: 0.8 cm.
Clay: outer, inner colour and fabric colour: 2.5Y 8/3 (pale brown); sand inclusions; medium-high firing temperature.
Description: convex base.

AbT.15.339.3 - Fig. 8.76

Dimensions: walls th.: 0.8 cm; base diam.: 11 cm; base th.: 1.1 cm.
Clay: outer and inner colour: 2.5Y 8/3 (pale brown); fabric colour: 7.5YR 6/4 (light brown); sand inclusions; medium firing temperature.
Description: convex base.

AbT.15.339.4 - Fig. 8.76

Dimensions: rim diam.: 15 cm; rim th.: 0.9 cm; walls th.: 0.9 cm.
Clay: outer and inner colour: 10YR 8/2 (very pale brown); fabric colour: 2.5Y 7/3 (pale brown); sand inclusions; medium-high firing temperature.
Description: plain rim jar.

AbT.15.339.5 - Fig. 8.76

Dimensions: rim diam.: 8 cm; rim th.: 0.5 cm; walls th.: 0.5 cm; base diam.: 4 cm; base th.: 1.3 cm; h.: 8.2 cm.
Clay: outer and inner colour: 7.5YR 6/4 (light brown); fabric colour: 7.5YR 5/4 (brown); sand inclusions; medium firing temperature.
Description: beaker with bitumen traces inside.

AbT.15.339.6 - Fig. 8.76

Dimensions: rim diam.: 12 cm; rim th.: 1.1 cm; walls th.: 1.2 cm.

Clay: outer, inner and fabric colour: 5YR 6/4 (light reddish brown); sand inclusions; medium firing temperature. Description: plain rim jar.

Catalogue of US 343 finds

Pottery

AbT.15.343.1 - Fig. 8.76

Dimensions: rim diam.: 39 cm; rim th.: 2.1 cm; walls th.: 1.5 cm.

Clay: outer colour and inner colour: 10YR 8/2 (very pale brown); fabric colour: 7.5YR 7/3 (pink); sand inclusions; medium firing temperature. Description: triangular rim bowl with a notched ridge, a line of small excisions and wavy incisions on the top.

AbT.15.343.2 - Fig. 8.76

Dimensions: walls th.: 0.6 cm; base diam.: 13 cm; base th.: 0.6 cm.

Clay: outer colour: 10YR 8/2 (very pale brown); inner colour: 10YR 7/3 (very pale brown); fabric colour: 7.5YR 7/3 (pink); sand inclusions; medium firing temperature.

Description: flat base.

AbT.15.343.3 - Fig. 8.76

Dimensions: rim diam.: 8 cm; rim th.: 0.4 cm; walls th.: 0.4 cm.

Clay: outer colour: 10YR 7/3 (very pale brown); inner and fabric colour: 5YR 6/4 (light reddish brown); sand inclusions; medium-low firing temperature.

Description: band rim jar.

Catalogue of US 346 finds

Pottery

AbT.16.346.1 - Fig. 8.76

Dimensions: rim diam.: 13.9 cm; rim th.: 0.7 cm; walls th.: 0.7 cm; base diam.: 5 cm; base th.: 1 cm; h.: 7.3 cm.

Clay: outer colour: 10YR 8/4 (very pale brown); inner colour: 5YR 6/6 (reddish yellow); fabric colour: 5YR 4/4 (reddish brown); sand inclusions; medium-low firing temperature.

Description: conical bowl.

AbT.16.346.2 - Fig. 8.76

Dimensions: rim diam.: 14 cm; rim th.: 0.6 cm; walls th.: 0.6 cm; base diam.: 5 cm; base th.: 0.7 cm; h.: 7.5 cm.

Clay: outer and inner colour: 2.5Y 7/3 (pale brown); fabric colour: 2.5Y 6/2 (greyish brown); sand inclusions; medium-high firing temperature.

Description: conical bowl.

AbT.16.346.3 - Fig. 8.76

Dimensions: rim diam.: 9.5 cm; rim th.: 0.6 cm; walls th.: 0.5 cm.

Clay: outer and inner colour: 10YR 8/3 (very pale brown); fabric colour: 5YR 5/4 (reddish brown); sand inclusions; medium firing temperature.

Description: plain rim jar.

AbT.16.346.4 - Fig. 8.76

Dimensions: rim diam.: 36 cm; rim th.: 1.5 cm; walls th.: 1 cm.

Clay: outer, inner and fabric colour: 10YR 8/2 (very pale brown); sand inclusions; medium-high firing temperature.

Description: triangular rim bowl.

AbT.16.346.5 - Fig. 8.76

Dimensions: rim diam.: 10 cm; rim th.: 0.8 cm; walls th.: 1 cm.

Clay: outer, inner and fabric colour: 7.5YR 6/4 (light brown); sand inclusions; medium firing temperature. Description: band rim jar.

Catalogue of US 480 finds

Pottery

AbT.16.480.1 - Fig. 8.76

Dimensions: walls th.: 2.2 cm; base diam.: 42 cm; base th.: 1.3 cm.

Clay: outer, inner and fabric colour: 2.5Y 8/3 (pale brown); sand inclusions; medium-high firing temperature. Description: triangular rim bowl.

Catalogue of US 487 finds

Objects

AbT.17.90 - Fig. 8.74

Description: stone tool fragment.

Dimensions: 9.6x6.7x10.4 cm; weight 921 gr.

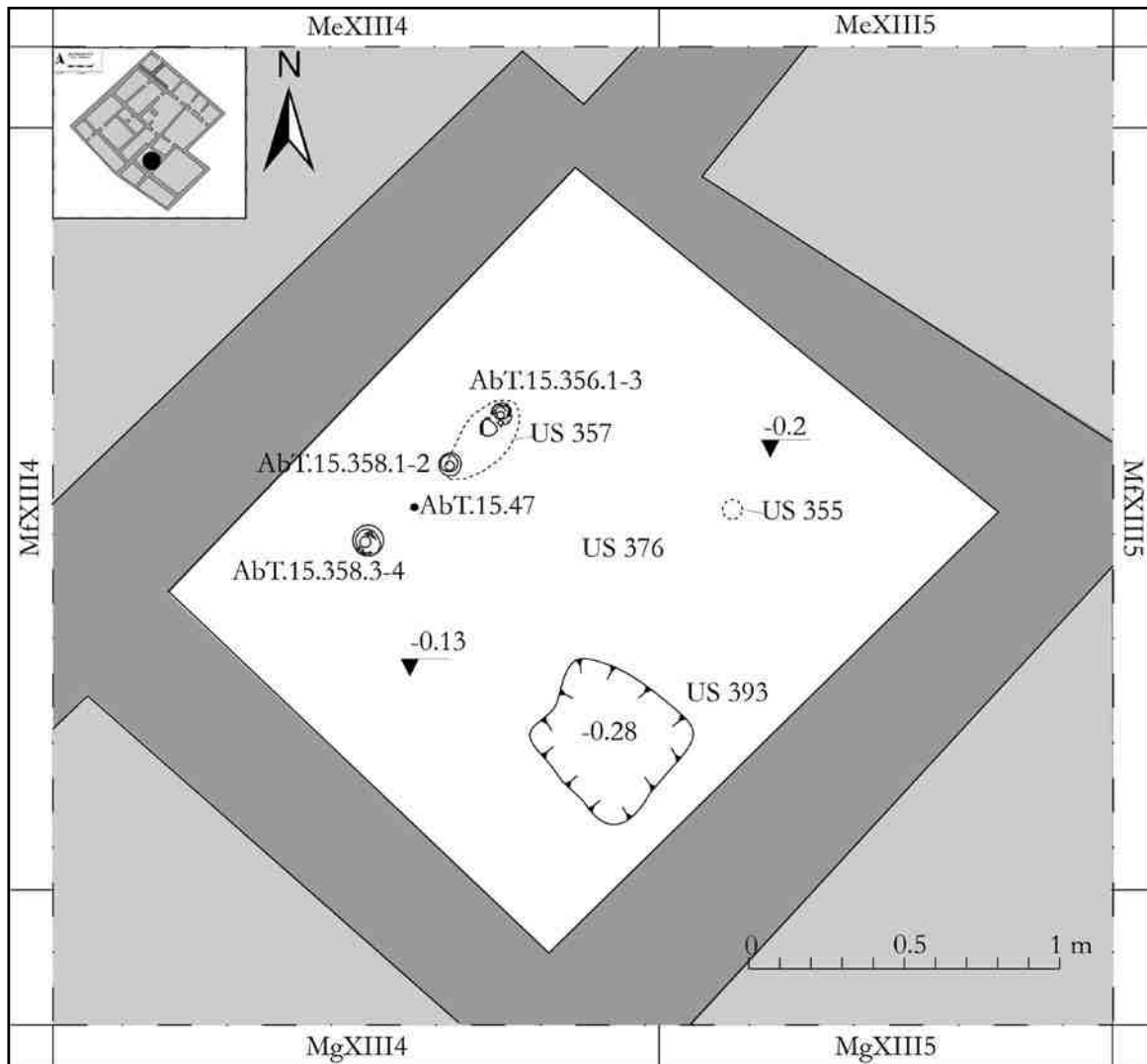

Fig. 8.77 Room 16.

8.15 ROOM 16 [LR]

The Room (Fig 8.77) was filled by US 358²⁶ and cut by a post-hole (US 354-355) and by a later oval pit (US 356-357) that contained at its very bottom three conical bowls (elevation -0.08 m).²⁷ After the excavation of US 358 other 2 conical bowls were discovered on the same line (US 364; elevation -0.08 m).²⁸ It is thus not clear if the pit US 357 reached the level of the two bowls²⁹ or if

this is the evidence of a later phase of the Building completely eroded in the other parts of the Building. US 376 was distinguished on the base of the presence over it of the conical bowls: though not clearly identified, US 376 should correspond to the housing surface (elevation -0.13).³⁰ The pit US 392-393, cutting US 376, contained several fragments of pottery mostly belonging to drinking vessels.

²⁶ The US contained mostly drinking vessels.

²⁷ The 3 conical bowls were considered as belonging to Building A - phase 1.

²⁸ The 4 conical bowls (two of them belonging to US 364) were wrongly assigned to US 358. The numbering was not changed in order to not create further mistakes in the documentation.

²⁹ Towards this hypothesis points the fact that pit US 357 only partially cut the northern bowls of US 364.

³⁰ The pavement cut by several pits was not reliable and thus not sampled for heavy residue analysis. The pottery found on and inside it consisted mainly of drinking vessels and to some jars. Some shards showed bitumen and burning traces.

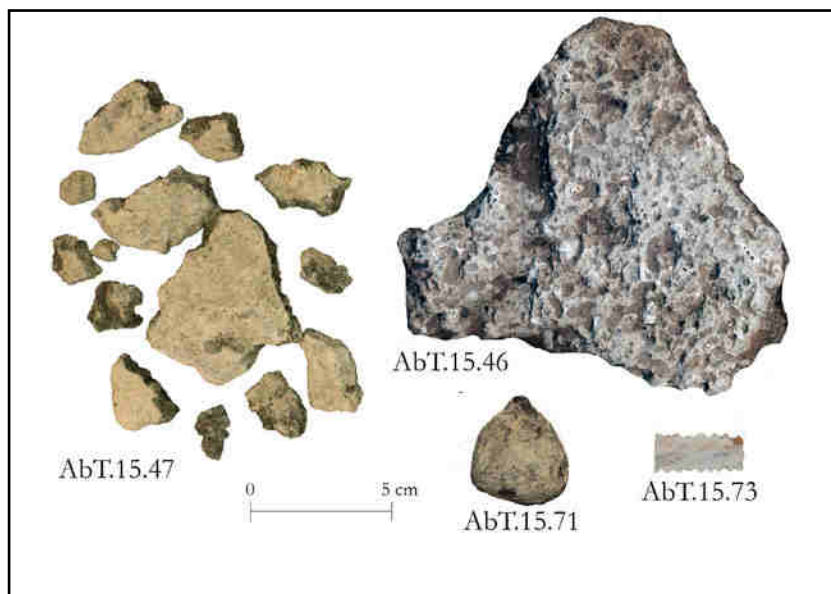

Fig. 8.78 US 358 objects.



Fig. 8.79 US 376 objects.



Fig. 8.80 US 392 objects.

Catalogue of US 356 Finds

*Pottery***AbT.15.356.1 - Fig. 8.81**

Dimensions: rim diam.: 15 cm; rim th.: 0.6 cm; wall th.: 0.9 cm; base diam.: 4 cm; base th.: 0.9 cm; h.: 8 cm.

Clay: outer and inner colour: 10YR 8/3 (very pale brown); fabric colour: 5YR 6/4 (light reddish brown); sand inclusions; medium firing temperature. Description: conical bowl.

AbT.15.356.2 - Fig. 8.81

Dimensions: rim diam.: 15 cm; rim th.: 0.6 cm; wall th.: 0.6 cm; base diam.: 4.5 cm; base th.: 1 cm; h.: 6.6 cm.

Clay: outer, inner and fabric colour: 5YR 5/6 (yellowish red); sand inclusions; medium-low firing temperature. Description: conical bowl.

AbT.15.356.3 - Fig. 8.81

Dimensions: rim diam.: 15 cm; rim th.: 0.7 cm; wall th.: 0.8 cm; base diam.: 4.5 cm; base th.: 1 cm; h.: 6.7 cm.

Clay: outer and inner colour: 7.5YR 7/4 (pink); fabric colour: 5YR 6/4 (light reddish brown); sand inclusions; medium firing temperature. Description: conical bowl.

Catalogue of US 358 Finds

*Objects***AbT.15.46 - Fig. 8.78**

Description: grindstone (2 pieces). Dimensions: 15.6x5.3x11.6.

AbT.15.47 - Fig. 8.78

Description: various bitumen fragments. Dimensions: 4.6x5.4x5x2.2 cm (biggest fragment).

AbT.15.71 - Fig. 8.78

Description: bitumen pear-shaped object. Dimensions: 3.2x3.3x3.2 cm.

AbT.15.73 - Fig. 8.78

Description: chert sickle element. Dimensions: 0.4x3.2x0.5 cm.

*Pottery***AbT.15.358.1 - Fig. 8.81**

Dimensions: rim diam.: 19 cm; rim th.: 0.4 cm; wall th.: 0.8 cm; base diam.: 5 cm; base th.: 1.3 cm.

Clay: outer, inner and fabric colour: 5YR 5/6 (yellowish red); sand inclusions; medium firing temperature. Description: conical bowl.

AbT.15.358.2 - Fig. 8.81

Dimensions: rim diam.: 16 cm; rim th.: 0.4 cm; wall th.: 0.6 cm; base diam.: 5.5 cm; base th.: 1.2 cm.

Clay: outer, inner and fabric colour: 5YR 6/4 (light reddish brown); sand inclusions; medium firing temperature. Description: conical bowl.

AbT.15.358.3 - Fig. 8.81

Dimensions: rim diam.: 12 cm; rim th.: 0.7 cm; wall th.: 0.7 cm; base diam.: 5.5 cm; base th.: 0.7 cm; h.: 7.5 cm.

Clay: outer, inner and fabric colour: 10YR 7/4 (very pale brown); sand inclusions; medium-low firing temperature. Description: conical bowl.

AbT.15.358.4 - Fig. 8.81

Dimensions: rim diam.: 15 cm; rim th.: 0.5 cm; wall th.: 0.6 cm; base diam.: 5 cm; base th.: 1.3 cm; h.: 7.3 cm.

Clay: outer, inner and fabric colour: 10YR 8/3 (very pale brown); sand inclusions; medium-high firing temperature. Description: conical bowl.

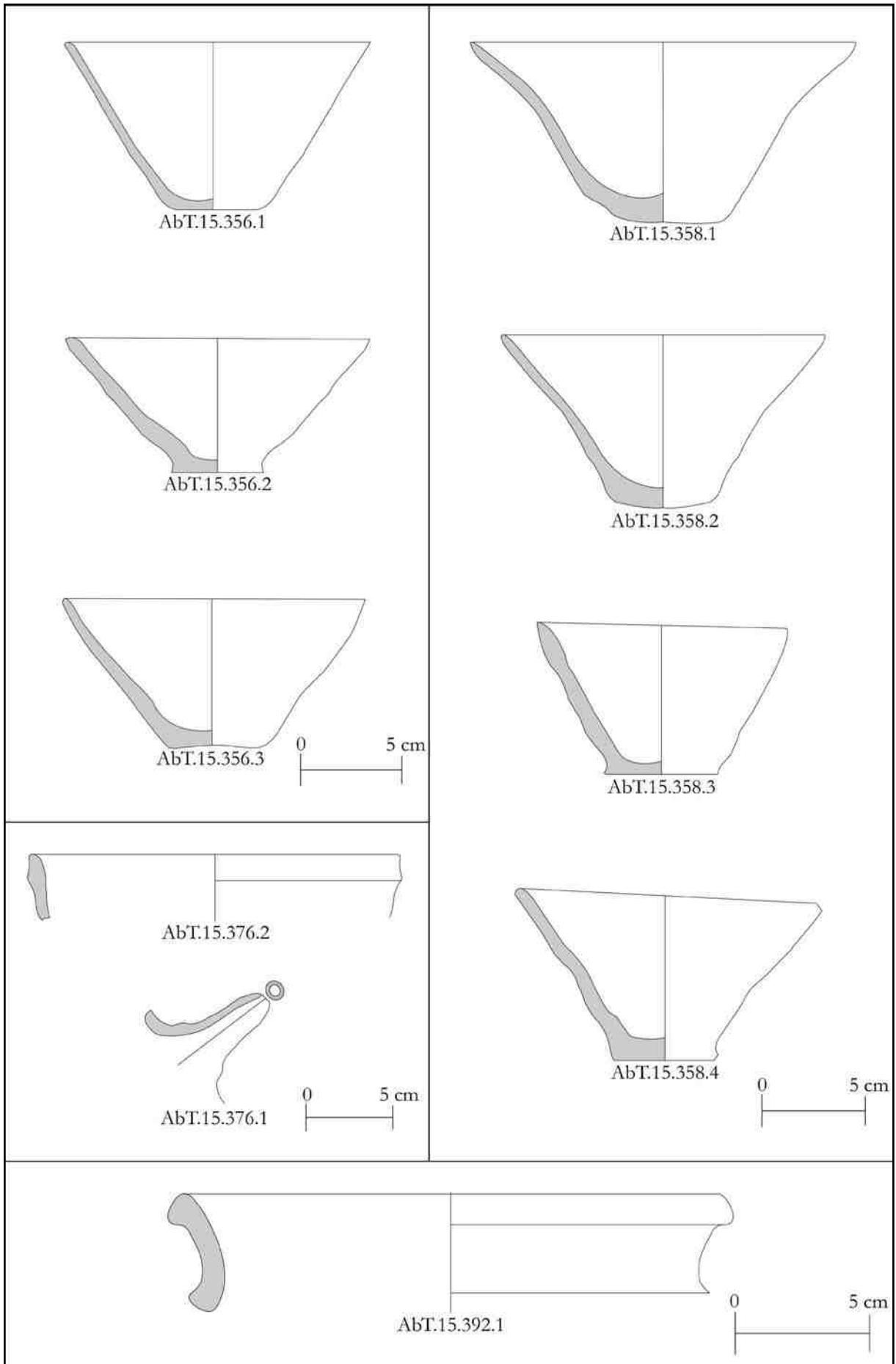

Fig. 8.81 US 356, US 358, US 376 and US 392 pottery.

Catalogue of US 376 Finds

*Objects***AbT.15.74 - Fig. 8.79**

Description: chert sickle element.
Dimensions: 1.3x2.2x0.2 cm.

*Pottery***AbT.15.376.1 - Fig. 8.81**

Dimensions: wall th.: 0.6 cm.
Clay: outer colour: 10YR 6/3 (pale brown); inner colour: 7.5YR 6/3 (light brown); fabric colour: 5YR 6/6 (reddish yellow); sand inclusions; medium-high firing temperature.
Description: spout.

AbT.15.376.2 - Fig. 8.81

Dimensions: rim diam.: 21 cm; rim th.: 1.1 cm.
Clay: outer and inner colour: 2.5Y 7/4 (pale brown); fabric colour: 5YR

5/4 (reddish brown); sand inclusions; medium firing temperature.
Description: band rim jar.

Catalogue of US 392 Finds

*Objects***AbT.15.100 - Fig. 8.80**

Description: copper alloy fragment.
Dimensions: 1.5x1.7x0.7 cm.

*Pottery***AbT.15.392.1 - Fig. 8.81**

Dimensions: rim diam.: 20 cm; rim th.: 1.5 cm; wall th.: 1.1 cm.
Clay: outer and inner colour: 2.5Y 6/3 (light yellowish brown); fabric colour: 2.5Y 7/3 (pale brown); sand inclusions; medium-high firing temperature.
Description: triangular rim jar.

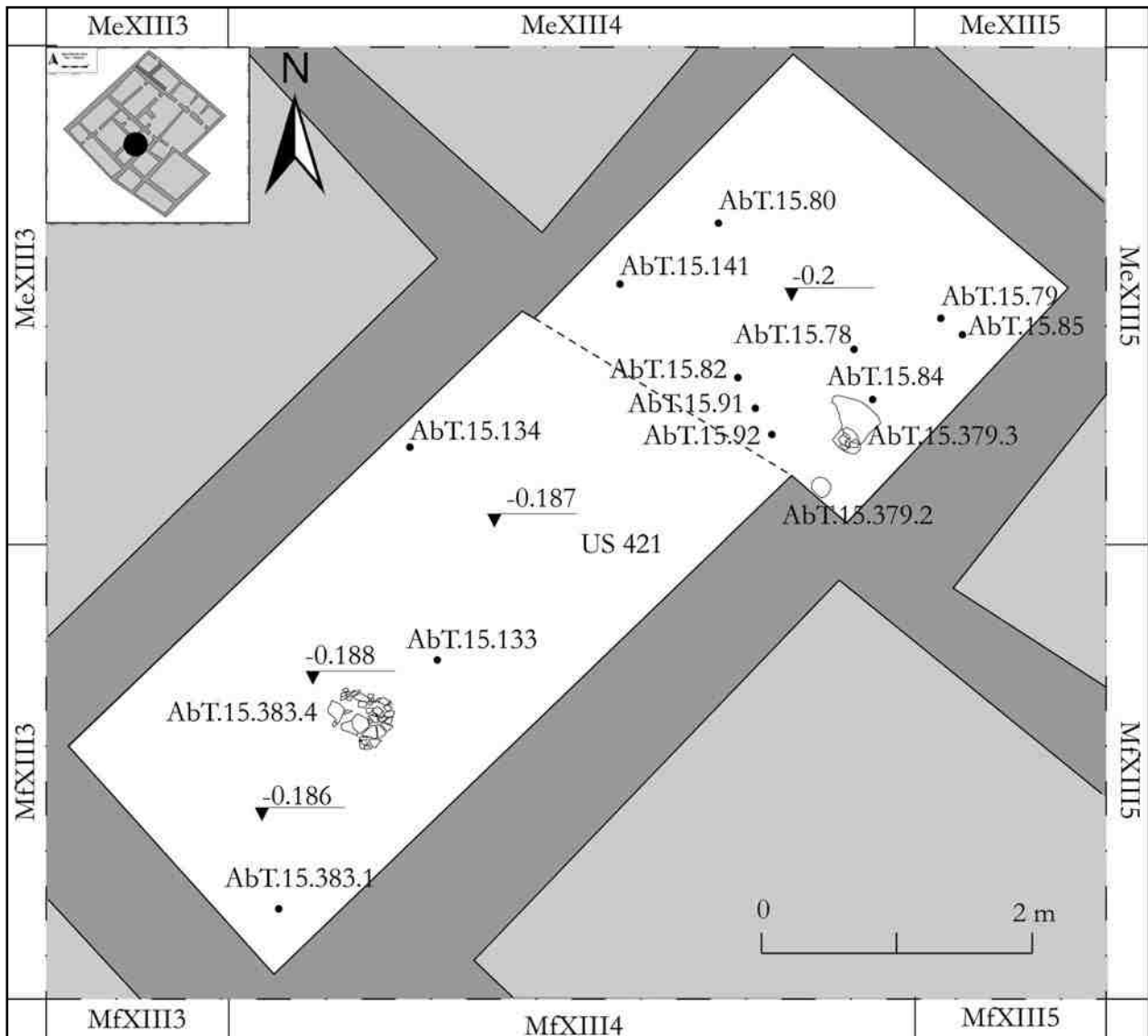

Fig. 8.82 Room 17+19+21 plan.

8.16 ROOM 17+19+21 [LR]

The Room (Fig. 8.82) was initially excavated in three separated parts, because of an erroneous interpretation of the surface based on satellite imagery. The situation in this area, much like the surrounding rooms, was initially misinterpreted due to later activities carried out on the spot that uniformed the surface: indeed, also this room was not visible from the satellite imagery. The plan of the Room is characterized by the enlargement of the space in its northern part, forming in this way a small “L”, with the south-eastern wall slightly bent in a small corner. The Room was filled by a clay horizontal stratum (US 379=383). On the pavement, in the northern section of the Room, a grindstone (AbT.15.84) and a big bowl

(AbT.15.379.3) were found,³¹ while a conical bowl was near the wall off-set. In the southern part there were several fragments of a rounded shoulder jar with “reserved-slip like effect” (AbT.15.383.4). The pavement (US 421) was sampled for heavy residue analysis (only in the northern part where it was identified).

³¹ The US contained also some drinking vessels and several fragments of at least two different jars.

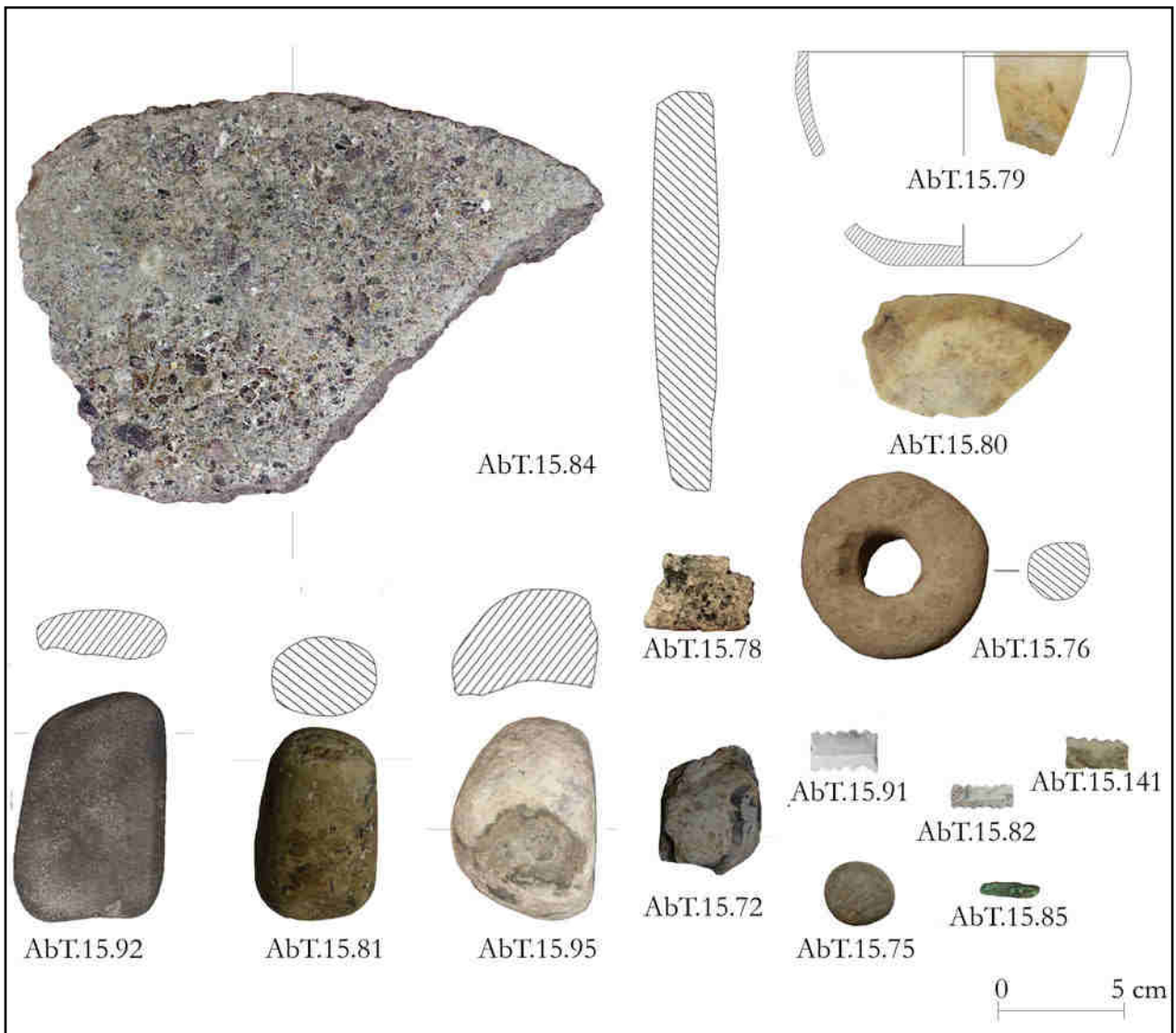

Fig. 8.83 US 379 objects.



Fig. 8.84 US 383 objects.

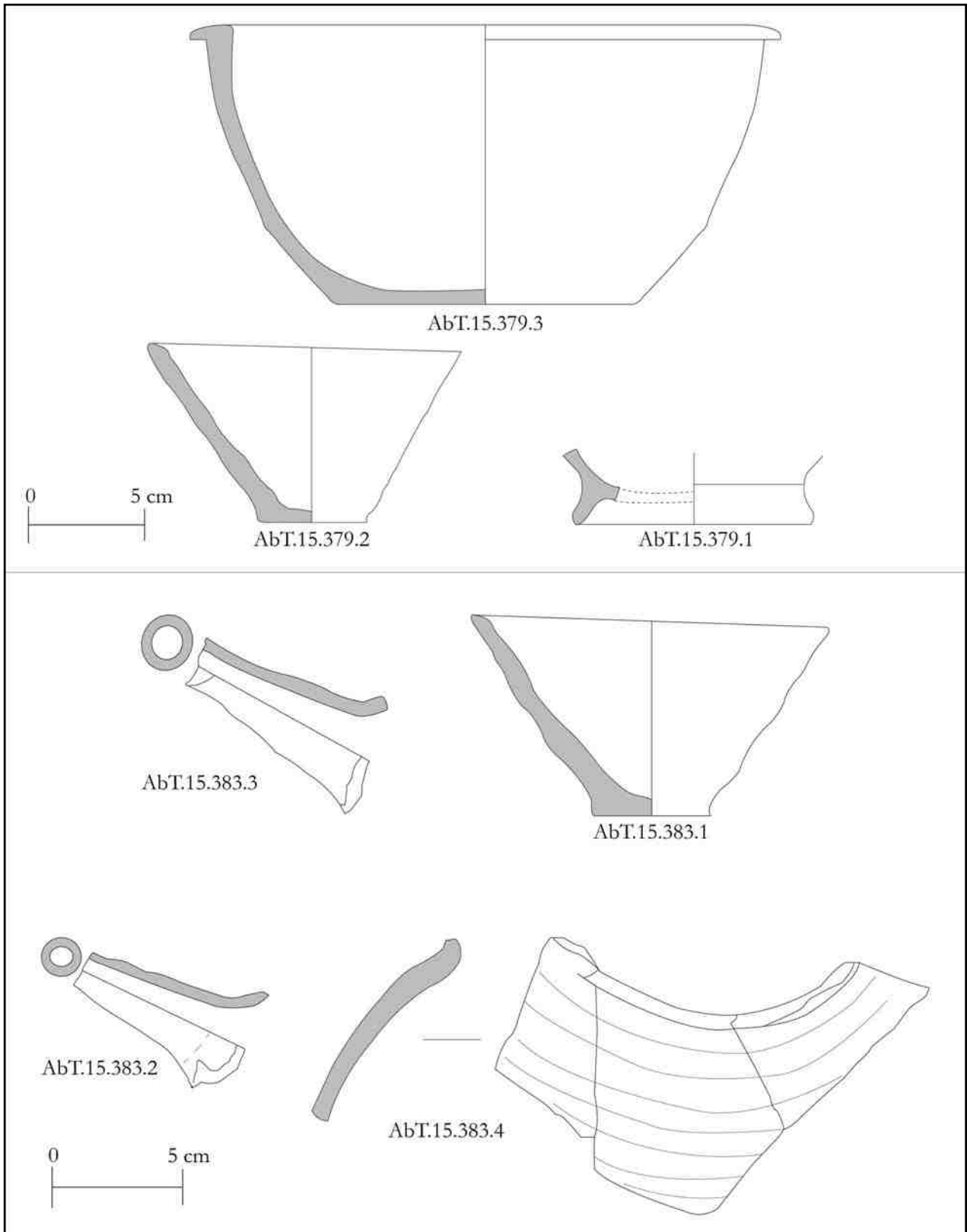

Fig. 8.85 US 379 and US 383 pottery.

Catalogue of US 379 Finds

Dimensions: 4x5.2x3.4 cm; weight 103 gr.

Dimensions: 2.6x2.8x0.9 cm; weight 11 gr ca.

Objects

AbT.15.72 - Fig. 8.83

Description: chert cube fragment.

AbT.15.75 - Fig. 8.83

Description: small river pebble. Small striations on both surfaces, but hard to tell if technological. [SC]

AbT.15.76 - Fig. 8.83

Description: pottery loom weight; circular form.

Dimensions: 2.6 cm (internal diameter); 6.4x1.9x2.6x6.5 cm.

AbT.15.78 - Fig. 8.83

Description: bitumen object fragment.
Dimensions: 2.7x3.6x4.1x1.5 cm.

AbT.15.79 - Fig. 8.83

Description: rim of an alabastrine limestone bowl with a small inflexion under the rim. The outer and inner surface of the fragment have sub-parallel, vertical and horizontal striations. The rim presents a very polished surface. [SC]
Dimensions: 3x4.3x4.1x0.1x13 cm.

AbT.15.80 - Fig. 8.83

Description: base of alabastrine limestone vessel. The underside of the base shows heavy rounding due to contact. The fragmented sides show thinning of the wall and the fragmented sections show light rounding on certain fractions. The outer part of the wall and the inner part of the base has light striations. [SC]
Dimensions: 8x1.7x4.6x0.6x6 cm.

AbT.15.81 - Fig. 8.83

Description: small stone pestle. The lateral surfaces show traces of slight rounding and/or polishing. The two endings were used for pounding activities. [SC]
Dimensions: 4.1x7x3.9 cm.

AbT.15.82 - Fig. 8.83

Description: chert sickle element.
Dimensions: 1x2.5x0.3 cm.

AbT.15.84 - Fig. 8.83

Description: fragmentary grindstone.
Dimensions: 15x3x20.5 cm

AbT.15.85 - Fig. 8.83

Description: copper alloy fragment.
Dimensions: 2.6x0.6x0.6 cm.

AbT.15.91 - Fig. 8.83

Description: chert sickle element.
Dimensions: 1.6x0.4x2.7 cm.

AbT.15.92 - Fig. 8.83

Description: multifunctional stone tool with unusual shape. Possibly used for expedient polishing and pounding. Slightly fractured, with a strange shape and unknown function. Traces of pounding are visible in the corners.

Long side and one angle probably used for polishing. [SC]

Dimensions: 5.8x2x9.5 cm; weight 255 gr.

AbT.15.95 - Fig. 8.83

Description: hammer-stone.. The whole fragment seems heavily burnt. Several areas of the stone tool were used for different activities: polishing or general levelling actions. One small lateral area of the object presents heavy traces of bitumen processing. However, the fire probably altered the traces. [SC]
Dimensions: 7.3x5x3.7 cm; weight 267 gr.

AbT.15.141 - Fig. 8.83

Description: chert sickle element.
Dimensions: 1.2x2.4x0.4 cm.

Pottery

AbT.15.379.1 - Fig. 8.85

Dimensions: base diam.: 10 cm; base th.: 0.8 cm.
Clay: outer colour: 2.5YR 6/3 (light reddish brown); inner colour: 10YR 5/4 (yellowish brown); fabric colour: 5YR 5/4 (reddish brown); sand inclusions; medium-low firing temperature.
Description: ring base.

AbT.15.379.2 - Fig. 8.85

Dimensions: rim diam.: 14.2 cm; rim th.: 0.7 cm; wall th.: 0.7 cm; base diam.: 4.5 cm; base th.: 0.8 cm; h.: 7.5 cm.
Clay: outer colour: 10YR 7/3 (very pale brown); inner colour: 5YR 5/4 (reddish brown); fabric colour: 5YR 4/6 (yellowish red); sand inclusions; medium-low firing temperature.
Description: conical bowl.

AbT.15.379.3 - Fig. 8.85

Dimensions: rim diam.: 24.5 cm; rim th.: 1.6 cm; wall th.: 1.1 cm; base diam.: 13 cm; base th.: 0.8 cm; h.: 12 cm.
Clay: outer, inner and fabric colour: 10YR 7/3 (very pale brown); sand inclusions; medium firing temperature.
Description: triangular rim bowl.

Catalogue of US 383 Finds

Objects

AbT.15.131 - Fig. 8.84

Description: copper alloy double pointed object.
Dimensions: 1.1x5.1x0.7 cm.

AbT.15.132 - Fig. 8.84

Description: pebble.
Dimensions: 1.3x3.1x1.2 cm; weight 6 gr.

AbT.15.133 - Fig. 8.84

Description: chert flake.
Dimensions: 3.1x3x0.6 cm.

AbT.15.134 - Fig. 8.84

Description: basalt flake.
Dimensions: 2.2-2.5x3.7-1.8x0.6 cm.

AbT.15.136 - Fig. 8.84

Description: chert flake.
Dimensions: 1.5x1.9x0.6 cm.

Pottery

AbT.15.383.1 - Fig. 8.85

Dimensions: rim diam.: 14 cm; rim th.: 0.6 cm; wall th.: 0.7 cm; base diam.: 4.5 cm; base th.: 0.9 cm; h.: 7.4 cm.
Clay: outer, inner and fabric colour: 5YR 6/4 (light reddish brown); sand inclusions; medium firing temperature.
Description: conical bowl.

AbT.15.383.2 - Fig. 8.85

Dimensions: wall th.: 0.4 cm.
Clay: outer and inner colour: 5Y 8/2 (pale yellow); fabric colour: 2.5Y 7/3 (pale brown); sand inclusions; medium-high firing temperature.
Description: spout.

AbT.15.383.3 - Fig. 8.85

Dimensions: wall th.: 0.6 cm.
Clay: outer, inner and fabric colour: 5Y 8/2 (pale yellow); sand inclusions; medium-high firing temperature.
Description: spout.

AbT.15.383.4 - Fig. 8.85

Dimensions: wall th.: 1 cm.
Clay: outer, inner and fabric colour: 7.5YR 5/3 (brown); sand inclusions; medium-high firing temperature.
Description: rounded shoulder of a jar with "reserved slip like effect".

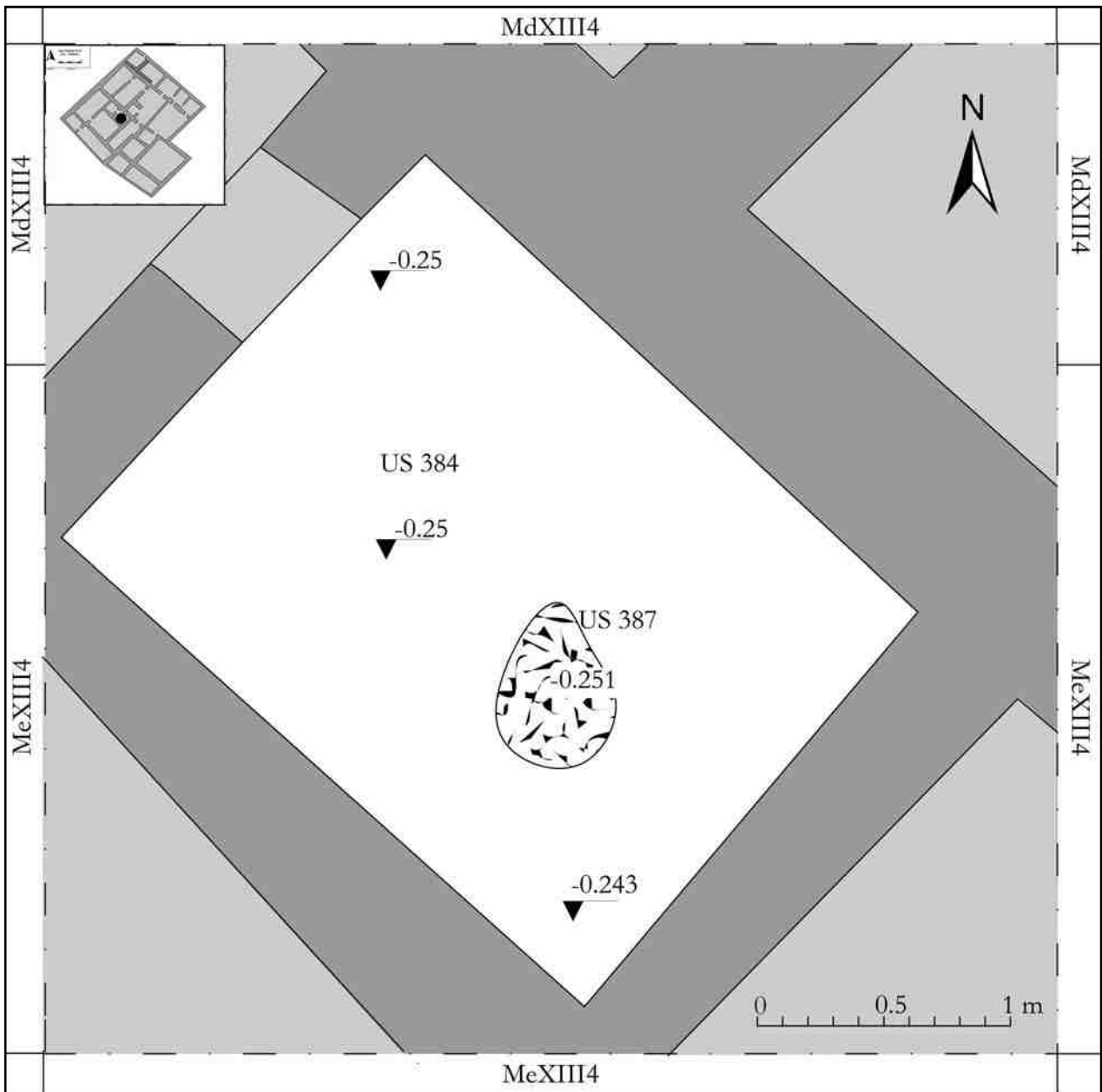

Fig. 8.86 Room 18.

8.17 ROOM 18 [LR]

The silty clay filling of the Room (US 381; Fig. 8.86) was characterized by the presence of several mud-brick fragments and pottery shards.³²

The ground-surface (US 384), sampled for heavy residue analysis, hosted a fireplace (US 387), located in the south-eastern part of the Room.

³² Few pottery shards were found in the stratum, including at least two drinking vessels, a fragment of a big vat and several walls of pottery with bitumen traces (some of them showing burning traces).

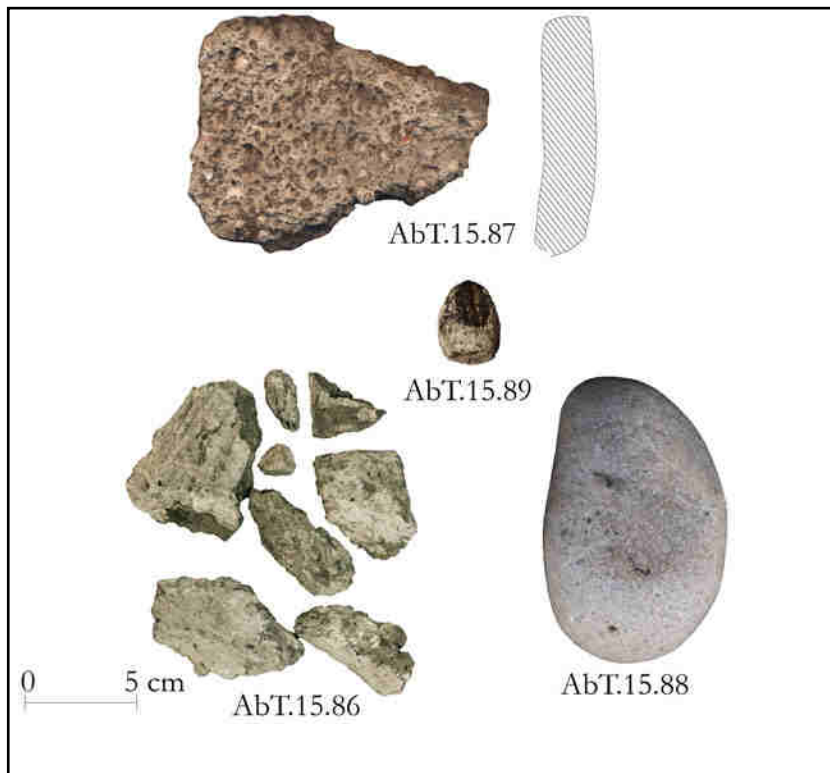

Fig. 8.87 US 381 objects.

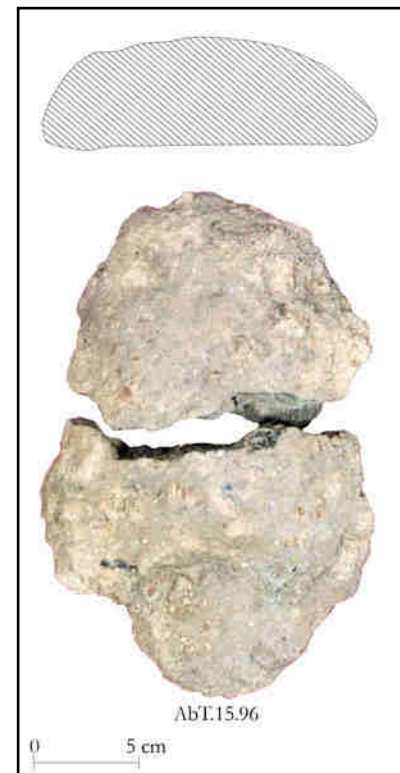

Fig. 8.88 US 384 objects.

Catalogue of US 381 Finds

Objects

AbT.15.86 - Fig. 8.87

Description: bitumen fragment.
Dimensions: 5x6.7x6.8x2.1 cm.

AbT.15.87 - Fig. 8.87

Description: grindstone.
Dimensions: 0.3x3.4x16.1 cm.

AbT.15.88 - Fig. 8.87

Description: stone tool. Microscopically no traces were observable, neither at high or low magnifications. Macroscopically some polishing and light pounding traces are evident. One functional surface, characterized by a darker colour (on the side of the tool) seems to have been used for polishing activities. [SC]
Dimensions: 7.4x5.8x11.6 cm; weight 710 gr.

AbT.15.89 - Fig. 8.87

Description: bitumen “pear-shaped” object.
Dimensions: 2.6x2.4x3.3x2.3 cm.

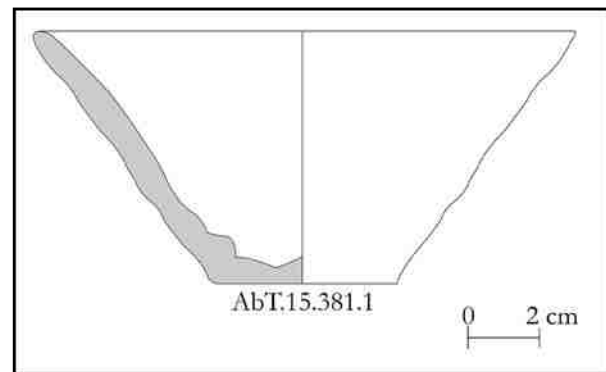

Fig. 8.89 US 381 pottery.

Pottery

AbT.15.381.1 - Fig. 8.89

Dimensions: rim diam.: 15 cm; rim th.: 0.6 cm; wall th.: 0.6 cm; base diam.: 5 cm; base th.: 1.2 cm; h.: 7 cm.
Clay: outer colour: 10YR 6/3 (pale brown); inner colour: 2.5YR 5/6 (red); fabric colour: 7.5YR 6/4 (light brown); sand inclusions; medium-low firing temperature.
Description: conical bowl.

Catalogue of US 384 Finds

Objects

AbT.15.96 - Fig. 8.88

Description: grindstone.
Dimensions: 10.5x5.1x13 cm.

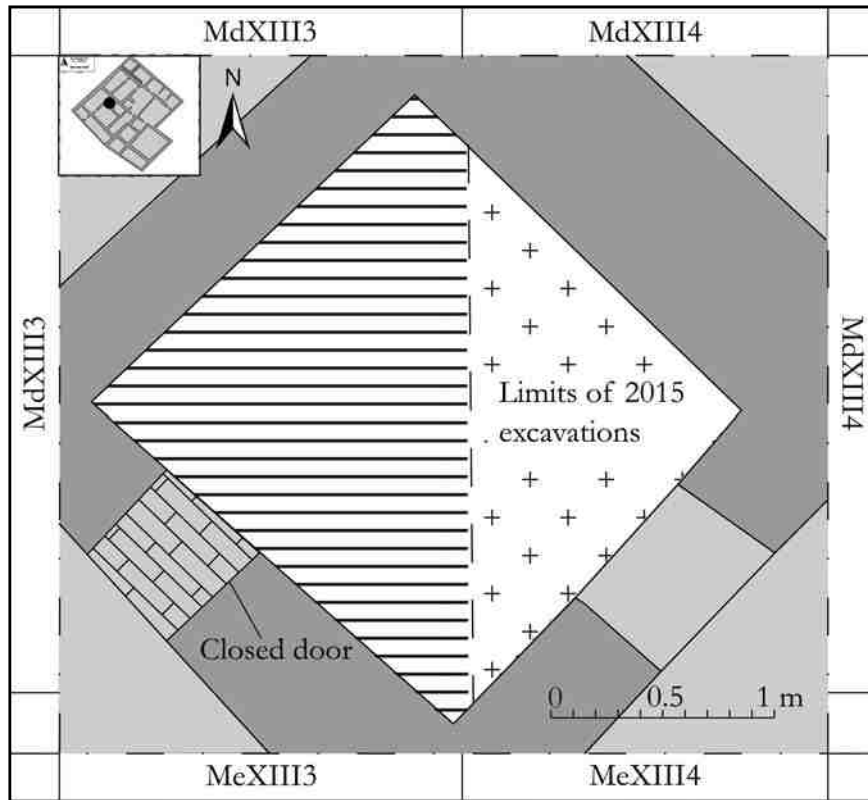

Fig. 8.90 Room 20 plan.

8.18 ROOM 20 [LR]

The Room (Fig. 8.90) was a small space unfortunately completely destroyed by the strong seasonal rainfall of the last years. Indeed, one of the wall near the section of the 2012 excavations collapsed with most of the filling during the following years. US 420 was assigned to what remained of the filling.

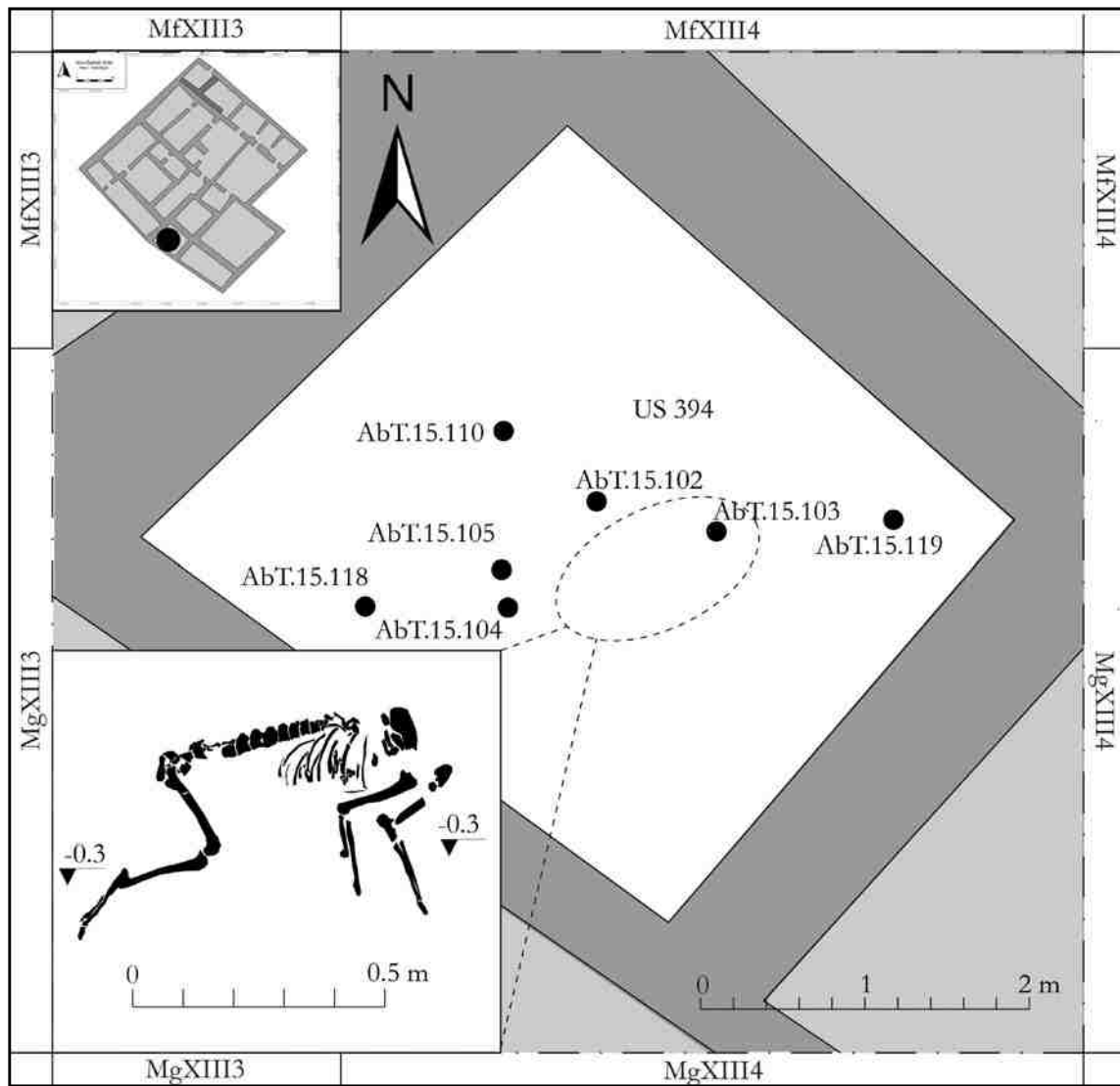

Fig. 8.91 Room 22 plan.

8.19 ROOM 22 [LR]

US 394 was the horizontal, quite hard, clay filling of Room 22 (from -0.08 to -0.3 m ca.).³³ No pavement was identified. The pottery found in the stratum comprised, as usual, mostly drinking vessels.³⁴ A dog skeleton with the head missing (US 405) was discovered under this stratum, at the elevation of -0.3 m (Figs 8.91-92). The skeleton was oriented south-west/north-east. No sign of the presence of a pit excavated in order to host the



Fig. 8.92 Room 22. Dog skeleton (US 405).

dog was clearly identified.³⁵ The stratum on which the dog was laying was called US 406.

³³ The objects in the plan were found at different elevations, all among -0.17 and -0.2 m with the exception of AbT.15.119 found at the elevation of -0.3 m.

³⁴ A total of 5 bases of conical bowls; 13 small fragments of plain rim jars; one base of jar with one foot preserved; a fragment of a conical bowl attached to a stand, one ring base of a vat; 1 triangular rim of a big bowl.

³⁵ Traces of what could be interpreted as a cut were identified towards north-east, but it was not possible to clearly delineate the supposed cut. In addition, it should be mentioned that the clay covering the dog was the same of that identified as US 406.

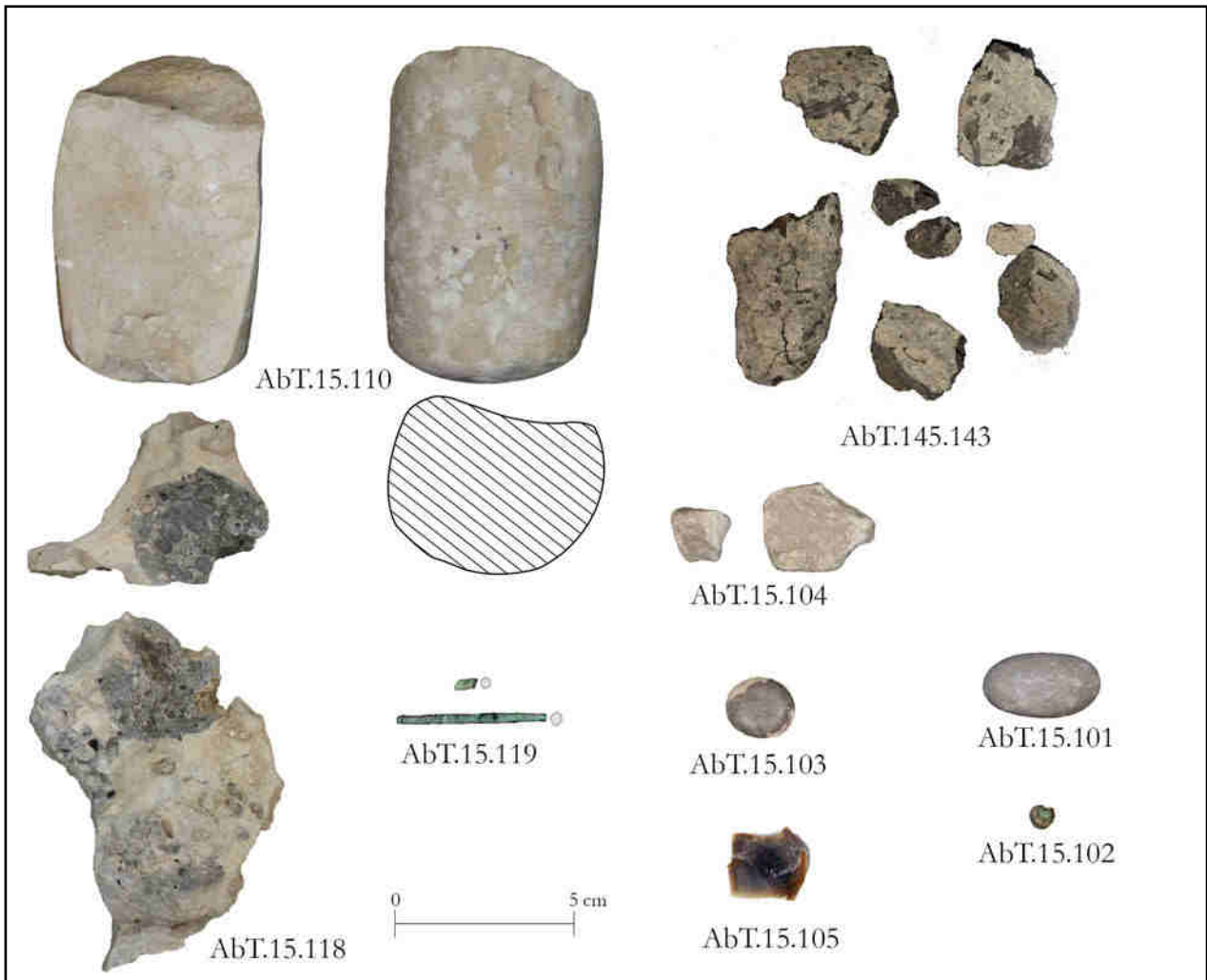

Fig. 8.93 US 394 objects.

Catalogue of US 394 Finds

Objects

AbT.15.101 - Fig. 8.93

Description: stone pebble.

Dimensions: 1.8x3x1.3 cm; weight 11 gr.

AbT.15.102 - Fig. 8.93

Description: copper alloy fragment.

Dimensions: 0.5x0.5x0.4 cm

AbT.15.103 - Fig. 8.93

Description: stone pebble.

Dimensions: 1.5x1.7x0.9 cm; weight 5 gr.

AbT.15.104 - Fig. 8.93

Description: stone vessel fragment. Very damaged: no traces visible. [SC]
Dimensions: 2.5x2.9x1 cm.

AbT.15.105 - Fig. 8.93

Description: chert bladelet.

Dimensions: 2.1x2.4x1 cm.

AbT.15.110 - Fig. 8.93

Description: half preserved hard stone pestle with many traces. The fractured side of the stone pestle presents a recycling use as abrader. The pestle functional area was used for pounding and has bitumen residue in the topographic lows. The sides of the object present widespread striations and a surface which seems to have been used for polishing since it is consumed and flattened. The main fracture seems to have been created by a direct blow, probably due to use. [SC]

Dimensions: 5.7x8.4x4.2 cm; weight 302 gr.

AbT.15.118 - Fig. 8.93

Description: vitrified clay (waste).

Dimensions: 6.5x12.2x4.4 cm.

AbT.15.119 - Fig. 8.93

Description: copper alloy fragments.

Dimensions: 0.3x4.1-0.6x0.3 cm.

AbT.15.143 - Fig. 8.93

Description: bitumen object.

Dimensions: 3.3x5x2.1 cm; weight 20 gr.

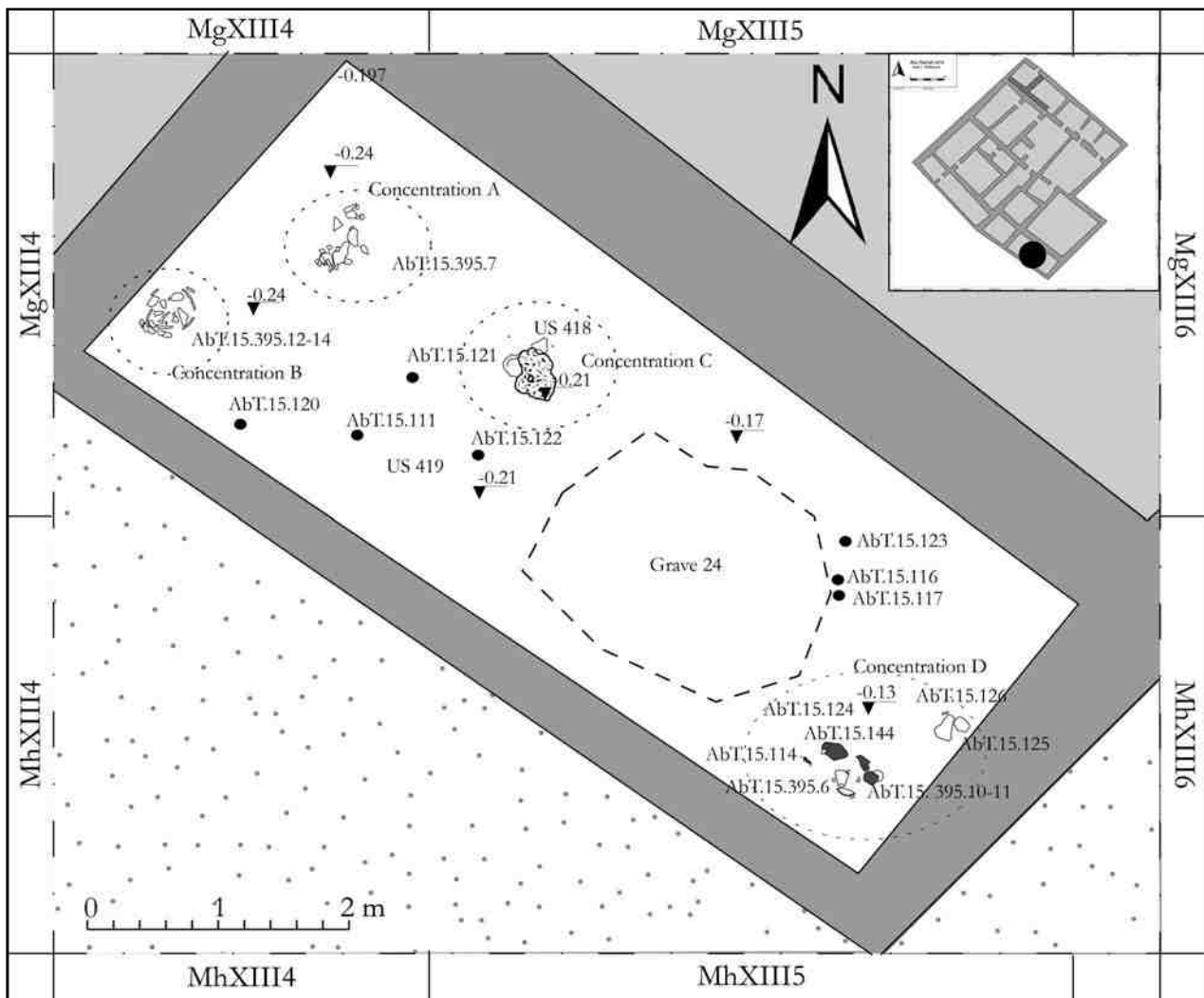

Fig. 8.94 Room 23 plan.

8.20 ROOM 23 [LR]

The Room (Fig. 8.94-95), cut by Grave 24, was filled by US 395, a yellowish brown clay soil, rich in salt crystals. The context was particularly interesting due to the exceptional amount of stone tools and other objects found *in situ* on the pavement (US 419). Four concentrations of pottery and other findings on the floor were named from A to D.³⁶ Concentration A (Fig. 8.96-97) was a plain rim jar with flat base, found upside down on the pavement. Concentration B (Fig. 8.98) contained

a band-rim jar and at least another closed shape.³⁷ The pavement (-0.2 m ca. of elevation),³⁸ sampled for heavy residue analysis and described in depth in § 9,³⁹ was characterized by the presence of a fireplace US 418 (Fig. 8.99) used for bitumen melting operations. A third group of findings was recovered in the southern part of the Room (Concentration D - Figs 9.100-101).

³⁶ The pottery and of the objects were found in some cases partially inserted into the pavement. For example, the sickle blade AbT.15.114 was sloping into the pavement US 419 (see also §§ 13-14). The catalogue indicates where the objects and the pottery was found..

³⁷ The other pottery fragments recovered mostly belonged to jars, some of them with burning and bitumen traces.

³⁸ The pavement slopes from north-west to south-east.

³⁹ Though the pavement was cut by Grave 24, the importance of the findings led us to perform this analysis in order to have a better understanding of the spatial distribution of the activities in the Room.



Fig. 8.95 Room 23.



Fig. 8.96 Room 23. Concentration A.



Fig. 8.97 AbT.15.395.7.



Fig. 8.98 Room 23. Concentration B.



Fig. 8.99 Room 23. Concentration C (US 418).

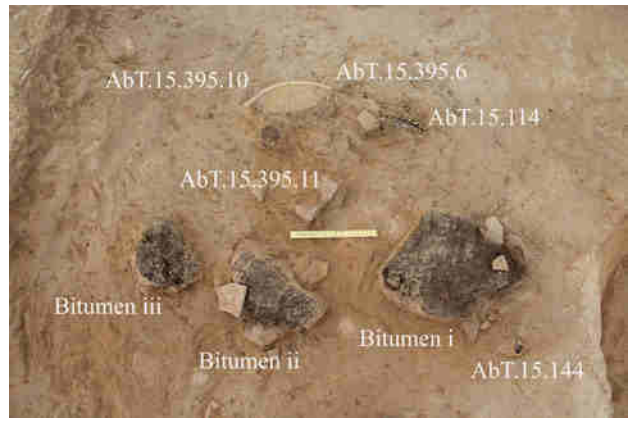

Fig. 8.100 Room 23. Concentration D.



Fig. 8.101 Room 23. Concentration D. AbT.15.114.

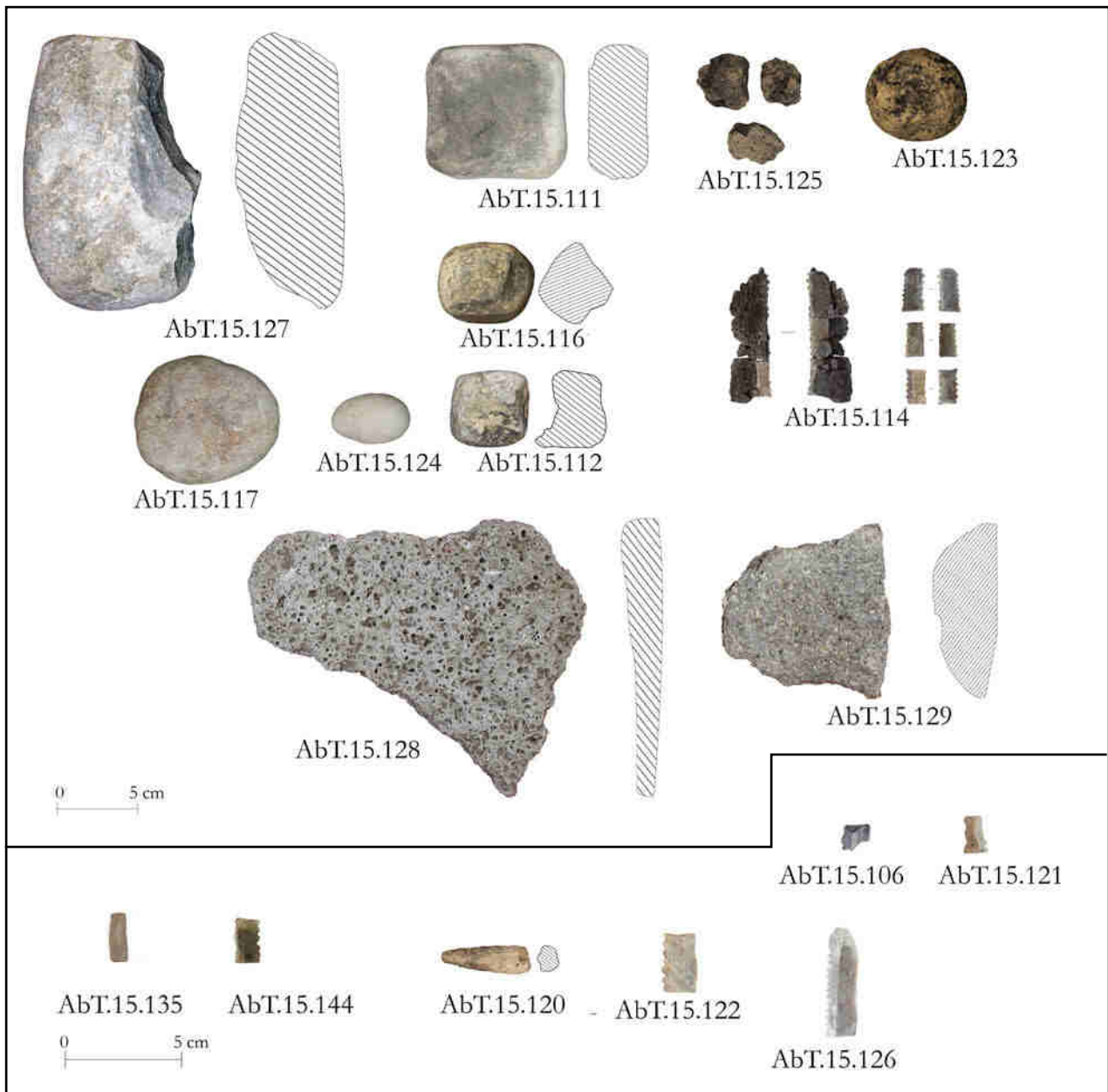

Fig. 8.102 US 395 objects.

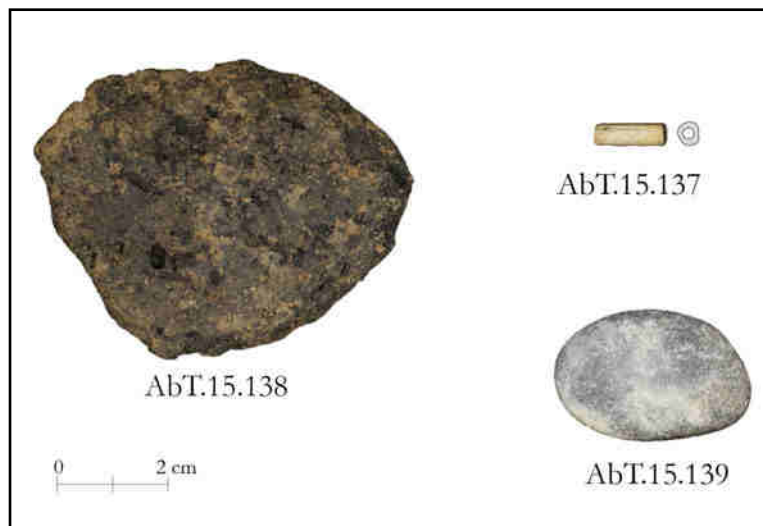

Fig. 8.103 US 419 objects.

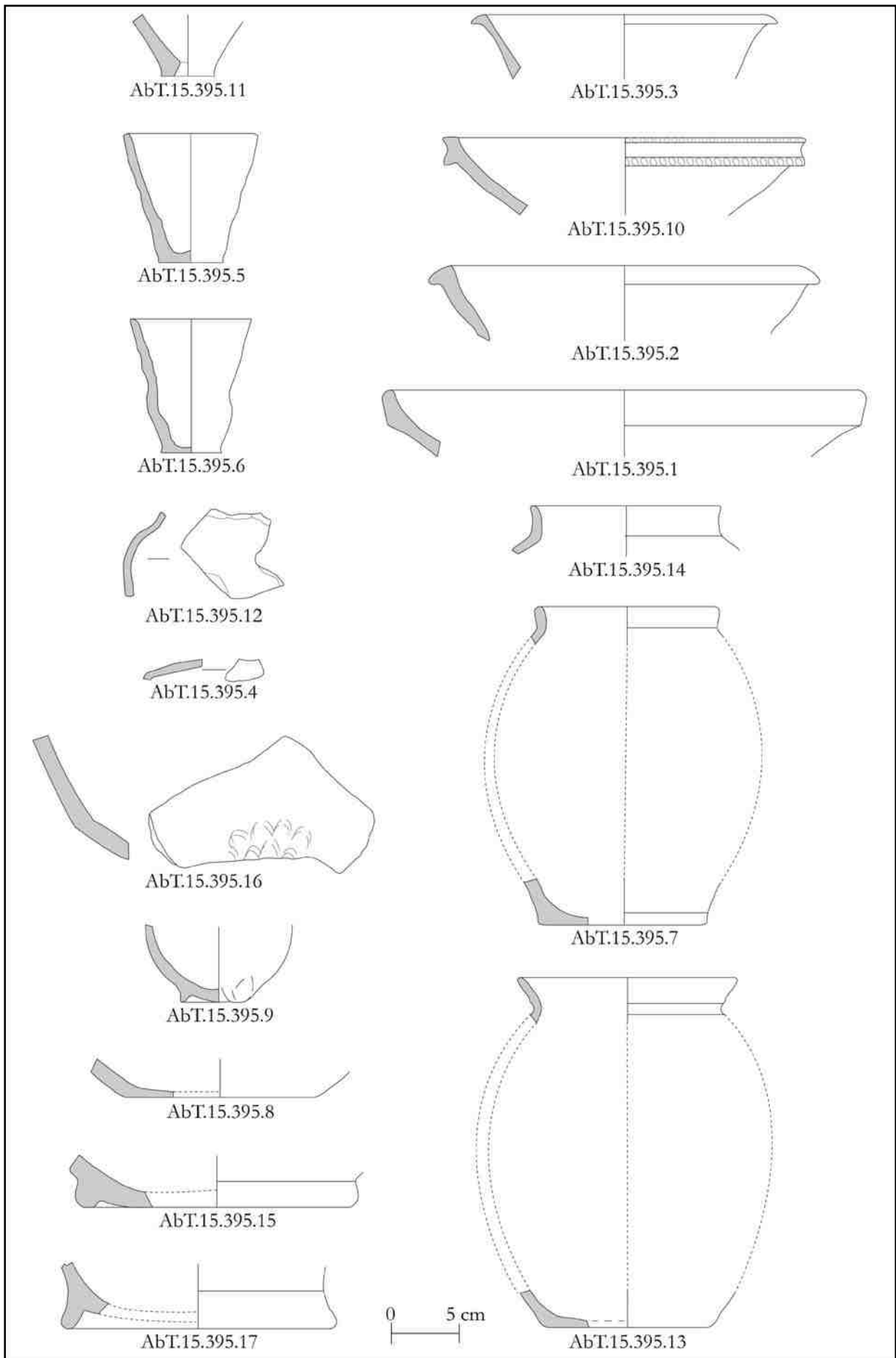

Fig. 8.104 US 395 pottery.

Catalogue of US 395 Finds

*Objects***AbT.15.106 - Fig. 8.102**

Description: chert blade fragment.
Dimensions: 1.4x1.3x0.4 cm.

AbT.15.111 - Fig. 8.102

Description: squared stone tool with one side covered by bitumen. [SC]
Dimensions: 8.1x8.1x4 cm; weight 550 gr.

AbT.15.112 - Fig. 8.102

Description: chert cube fragment. Very ruined and fractured. The patina covers most of the artifact but is less evident in the topographic lows. At high magnification microscopic flaking of the raw material is visible. [SC]
Dimensions: 4.6x5x3.9 cm.

AbT.15.114 - Fig. 8.102 and 14.10

Description: sickle with three chert elements.
Dimensions: (see §§ 14 and 15).

AbT.15.116 - Fig. 8.102

Description: stone cube. No functional traces. [SC]
Dimensions: 4.7x5.8x5.1 cm.

AbT.15.117 - Fig. 8.102

Description: slightly burnt hammerstone with traces due to pounding on the lateral sides of the entire object. [SC]
Dimensions: 7.6x8.2x4.7 cm.

AbT.15.120 - Fig. 8.102

Description: clay object fragment (leg of an animal figurine?).
Dimensions: 1.2x3.8 cm.

AbT.15.121 - Fig. 8.102

Description: chert bladelet with denticulate retouch on its right side.
Dimensions: 1.1x1.7x0.2 cm.

AbT.15.122 - Fig. 8.102

Description: chert sickle element.
Dimensions: 1.6x2.7x0.4 cm.

AbT.15.123 - Fig. 8.102

Description: bitumen object.
Dimensions: 5.5x5.8x4.4 cm.

AbT.15.124 - Fig. 8.102

Description: stone pebble.
Dimensions: 3x4.6x2.7 cm.

AbT.15.125 - Fig. 8.102

Description: bitumen object fragments.
Dimensions: 2.7x3.9x2.4 cm.

AbT.15.126 - Fig. 8.102

Description: chert blade with denticulate retouch.
Dimensions: 1.6x5.3x0.3 cm.

AbT.15.127 - Fig. 8.102

Description: fragment of a stone tool. No technological or functional traces visible. [SC]
Dimensions: 17x19.5x2.2 cm.

AbT.15.128 - Fig. 8.102

Description: grindstone.
Dimensions: 9.5x16 cm.

AbT.15.129 - Fig. 8.102

Description: grindstone.
Dimensions: 10.2x10x3.9 cm.

AbT.15.135 - Fig. 8.102

Description: chert bladelet.
Dimensions: 0.9x2.2x0.2 cm.

AbT.15.144 - Fig. 8.102

Description: chert sickle element.
Dimensions: 1.1x1.9x0.3 cm.

*Pottery***AbT.15.395.1 - Fig. 8.104**

Dimensions: rim diam.: 35(?) cm; rim th.: 1.1 cm; wall th.: 1.2 cm.
Clay: outer and fabric colour: 5YR 5/3 (reddish brown); inner colour: 5YR 5/2 (reddish grey); sand inclusions; medium-low firing temperature.
Description: stemmed-dish upper bowl.

AbT.15.395.2 - Fig. 8.104

Dimensions: rim diam.: 26 cm; rim th.: 2 cm; wall th.: 1 cm.
Clay: outer and fabric colour: 10YR 7/2 (light grey); inner colour: 7.5YR 5/3 (brown); sand inclusions; medium-low firing temperature.
Description: triangular rim bowl.

AbT.15.395.3 - Fig. 8.104

Dimensions: rim diam.: 21 cm; rim th.: 1.3 cm; wall th.: 0.8 cm.

Clay: outer colour: 5Y 7/3 (pale yellow); inner and fabric colour: 5Y 6/3 (pale olive); sand inclusions; medium-high firing temperature.

Description: triangular rim bowl.

AbT.15.395.4 - Fig. 8.104

Dimensions: wall th.: 0.8 cm.
Clay: outer and inner colour: 10YR 7/3 (very pale brown); fabric colour: 10YR 5/2 (greyish brown); sand inclusions; medium-high firing temperature.
Description: shoulder fragment.

AbT.15.395.5 - Fig. 8.104

Dimensions: rim diam.: 10.2 cm; rim th.: 0.5 cm; wall th.: 0.7 cm; base diam.: 4.5 cm; base th.: 0.8 cm; h.: 10 cm.
Clay: outer colour: 2.5Y 7/2 (light grey); inner and fabric colour: 2.5Y 7/4 (pale brown); sand inclusions; medium-high firing temperature.
Description: beaker.

AbT.15.395.6 - Fig. 8.104

Dimensions: rim diam.: 9 cm; rim th.: 0.5 cm; wall th.: 0.6 cm; base diam.: 4.5 cm; base th.: 0.7 cm; h.: 10 cm.
Clay: outer, inner and fabric colour: 5YR 6/4 (light reddish brown); sand inclusions; medium-low firing temperature.
Description: beaker.

AbT.15.395.7 - Fig. 8.97 and 104

Dimensions: rim diam.: 13 cm; rim th.: 0.6 cm; wall th.: 0.8 cm; base diam.: 12 cm; base th.: 0.9 cm.
Clay: outer colour: 10YR 6/3 (pale brown); inner and fabric colour: 10YR 4/3 (brown); sand inclusions; medium firing temperature.
Description: fragmentary jar with plain rim and flat base (concentration A).

AbT.15.395.8 - Fig. 8.104

Dimensions: base diam.: 14 cm; base th.: 0.4 cm.
Clay: outer, inner and fabric colour: 5YR 5/3 (reddish brown); sand inclusions; medium-high firing temperature.
Description: flat base of a jar (concentration D, under bitumen I).

AbT.15.395.9 - Fig. 8.104

Dimensions: rim diam.: 12.2 cm; rim th.: 0.6 cm; wall th.: 0.8 cm; base diam.: 5.5 cm; base th.: 1.1 cm; h.: 13.1 cm.
Clay: outer, inner and fabric colour: 7.5YR 6/3 (light brown); sand

inclusions; medium-high firing temperature.
Description: small jar base with three pinched feet (concentration D, under bitumen I).

AbT.15.395.10 - Fig. 8.104

Dimensions: rim diam.: 25 cm; rim th.: 1.1 cm.

Clay: outer, inner and fabric colour: 2.5Y 7/3 (pale brown); sand inclusions; medium-high firing temperature.

Description: stemmed-dish bowl (concentration D).

AbT.15.395.11 - Fig. 8.104

Dimensions: base diam.: 4 cm; base th.: 1 cm.

Clay: outer colour: 5YR 7/4 (pink); fabric colour: 5YR 5/3 (reddish brown); sand inclusions; medium firing temperature.

Description: conical bowl (concentration D).

AbT.15.395.12 - Fig. 8.104

Dimensions: wall th.: 0.6 cm.

Clay: outer colour: 10YR 6/4 (light yellowish brown); inner and fabric colour: 5YR 6/6 (reddish yellow); sand inclusions; medium firing temperature.

Description: rounded shoulder of a small jar (concentration B).

AbT.15.395.13 - Fig. 8.104

Dimensions: rim diam.: 16 cm; rim th.: 0.7 cm; base diam.: 12 cm; base th.: 0.9 cm; h.: 12 cm.

Clay: outer, inner and fabric colour: 2.5Y 7/3 (pale brown); sand inclusions; medium-high firing temperature.

Description: band rim jar with flat base.

AbT.15.395.14 - Fig. 8.104

Dimensions: rim diam.: 14 cm; rim th.: 0.7 cm.

Clay: outer, inner and fabric colour: 2.5Y 7/2 (light grey); sand inclusions; medium-high firing temperature.

Description: plain rim jar (concentration B).

AbT.15.395.15 - Fig. 8.104

Dimensions: base diam.: 20 cm; base th.: 1.4 cm.

Clay: outer, inner and fabric colour: 7.5YR 4/6 (strong brown); sand inclusions; medium-low firing temperature.

Description: ring base.

AbT.15.395.16 - Fig. 8.104

Dimensions: base th.: 1.1 cm.

Clay: outer, inner and fabric colour: 2.5YR 6/3 (light reddish brown); sand inclusions; medium-high firing temperature.

Description: convex base with finger prints visible.

AbT.15.395.17 - Fig. 8.104

Dimensions: base diam.: 18 cm; base th.: 0.7 cm.

Clay: outer colour: 2.5Y 7/3 (pale brown); inner and fabric colour: 7.5YR 7/4 (pink); sand inclusions; medium firing temperature.

Description: ring base.

Catalogue of US 419 Finds

Objects

AbT.15.137 - Fig. 8.103

Description: bone bead.

Dimensions: 0.2x1.1x0.3 cm.

AbT.15.138 - Fig. 8.103

Description: bitumen object.

Dimensions: 5x6.4x2.2 cm.

AbT.15.139 - Fig. 8.103

Description: stone pebble. No traces of use visible. [SC]

Dimensions: 2.4x3.4x0.9 cm; weight 12 gr.

8.21 BUILDING A NORTH-WESTERN OUTSIDE [LR]

The area immediately north-west of Room 1 was among the contexts excavated during the first season. The excavation in this area continued in 2013 and partially in 2017 (see Room 14-15). The area (Fig. 8.105) had a clear inclination from north-east to south-west as demonstrated by the accumulation of the characteristic seasonal greyish and yellowish strata visible also in the section (Fig. 6.10). These strata (US 21=29) were very soft and characterized by a silty and ashy matrix, with rare pottery shards. The drainage of the rainfall water was surely a problem for the inhabitants of Building A, as demonstrated by the drain pipe US 128 in square McXIII1, filled by US 127, surrounded by a pale brown mud-brick ring and hosted in a deep vertical cut US 199=135. One of the seasonal strata (US 200) was in connection with the top of the drain-pipe (ground-surface). An installation with a small circular mud structure (US 141) was located at north-west, near the perimeter wall of Building A, and was used to support a big jar decorated with wavy incised lines (US 143). In the jar filling (US 147) some pottery fragments were found. A pit (US 146-148) was located east of the jar installation and a tannur (US 139, filling 138) was discovered south of the installation, always along the perimetral wall and in correspondence of the dividing wall between Room 1 and Room 5. Under the ground surface US 200⁴⁰ there was a huge and complex system of three inhumations (Figs 8.105-106). This context was characterized by a series of different activities, that will be described here. In correspondence of the graves surface, there were two shallow soil heaps with a concentration of pottery and shells, called US 38 and US 134 (-0.1 m of elevation). The first heap was connected with two small burned areas (US 44) found in the middle of it. These heaps followed the line of the grave complex.⁴¹ At least 6 drinking vessels, 1 cylinder with and a upper bowl (?), two stems (or big bowls) and 3 jars come from US 38. US 152 contained at least 47 drinking vessels, 15 jars and some bowls. Moreover, this heap was

⁴⁰ Some pottery was found in connection with this US and can be related both to the use of the tannur or be connected to the shallow soil heaps US 38 and 134 (see below).

⁴¹ Some of the pottery fragments found on US 200 could also be related to this heap and be affected by post-depositional dislocation.

characterized by a significant dispersion of bivalve shells (see § 13.2.22). Under US 134, two pits were identified. The first pit US 36 was filled by a clay soil US 32 rich in mud-brick fragments.⁴² This pit, beginning at -0.25 m of elevation, reaching a depth of -0.58 m, cut the second one US 46. The second pit was identified at -0.3 m of elevation and reached a depth of -0.43 m; it was filled by US 45, a dark yellowish brown sandy and friable soil.

Due to the extremely difficult condition of the soil, with areas strongly cemented by salt, it was not possible to identify all the limits of the cuts. The limits and the walls of the main cut of the grave were reinforced with a mud-bricks cover in its lower part (US 47; Fig. 8.107).⁴³

On the bottom of the grave cut, over the mud-bricks (US 47), three bodies were discovered. While the south-western inhumation (Grave 4) was excavated during 2012, the second and the third ones (Grave 5 and 13) were completed in 2013.⁴⁴ The presence of a single cut (US 39=162=165) seems to point towards a contemporary inhumation of the three bodies and equipments (respectively, Grave 4 body US 43⁴⁵ and equipment US 37; Grave 5 body US 168 and equipment US 44-152; Grave 13 body US 164 and equipment 163).⁴⁶

The body of Grave 4 (US 43; Fig. 8.108) was found in foetal position, the head looking south-west. Part of the skull vault apparently crushed by the weight of the soil deposited above. The body was placed over mud-brick fragments.

On the contrary, the skeleton of Grave 5 (US 168; Fig. 8.109) was in very poor conditions: the body, oriented south-west/north-east, had a strongly squashed skull, the mandible dislocated and overturned; the ribs were not in their original

⁴² Fragments of a jar with bitumen traces inside were collected in the backfill.

⁴³ The cut, approximately rectangular but with rounded edges, was ca. 9 m long in the north-east/south-west direction. It was ca. 3 m wide, with almost vertical walls.

⁴⁴ D'Agostino *et al.* 2011: 29-30.

⁴⁵ Erroneously animal bones coming from Grave 4 and 5 were collected together.

⁴⁶ The soil covering the equipments has no US number because it is considered unreliable due to the difficulties in distinguishing it from the other activities.

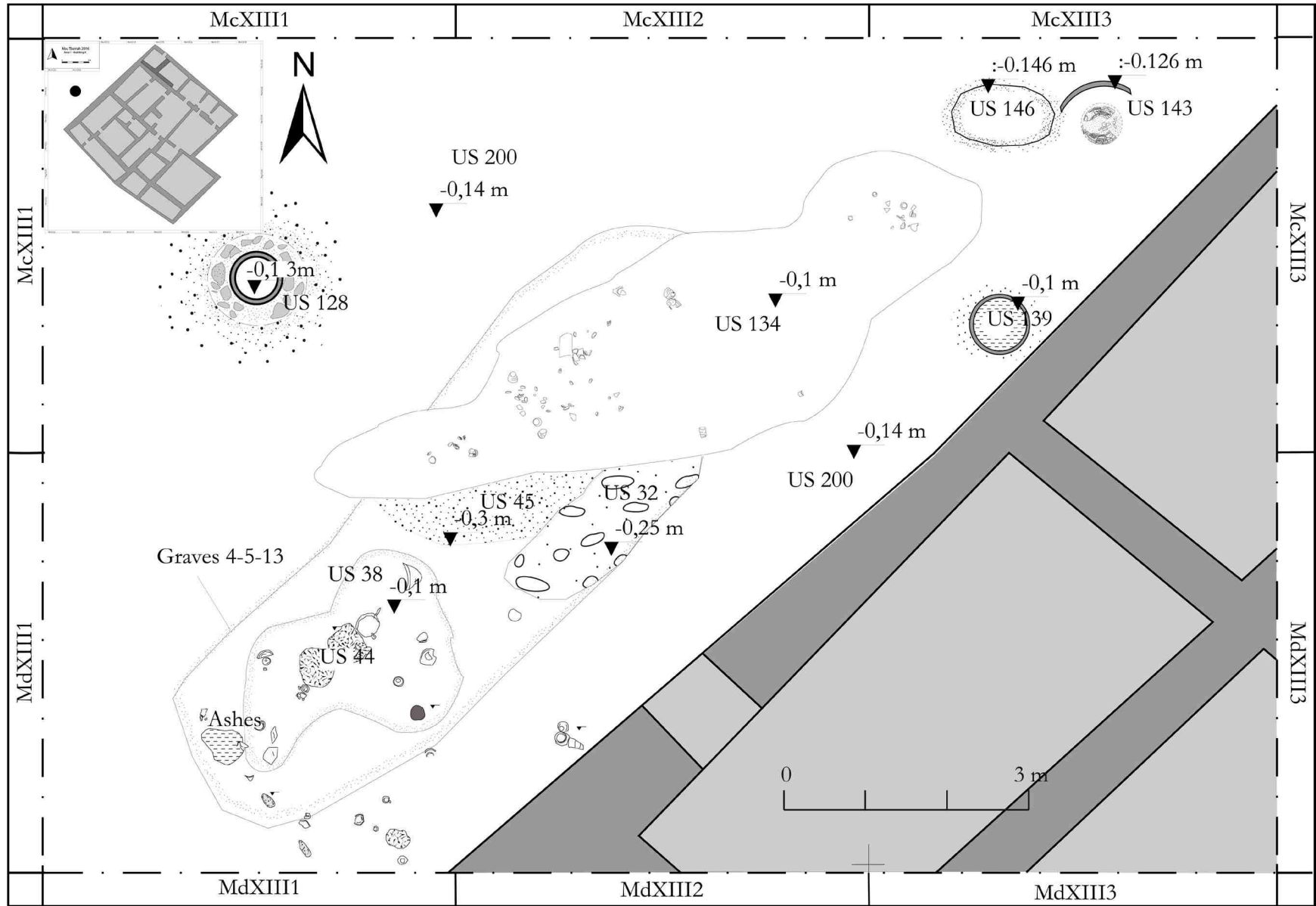

Fig. 8.105 Building A north-western outside plan.

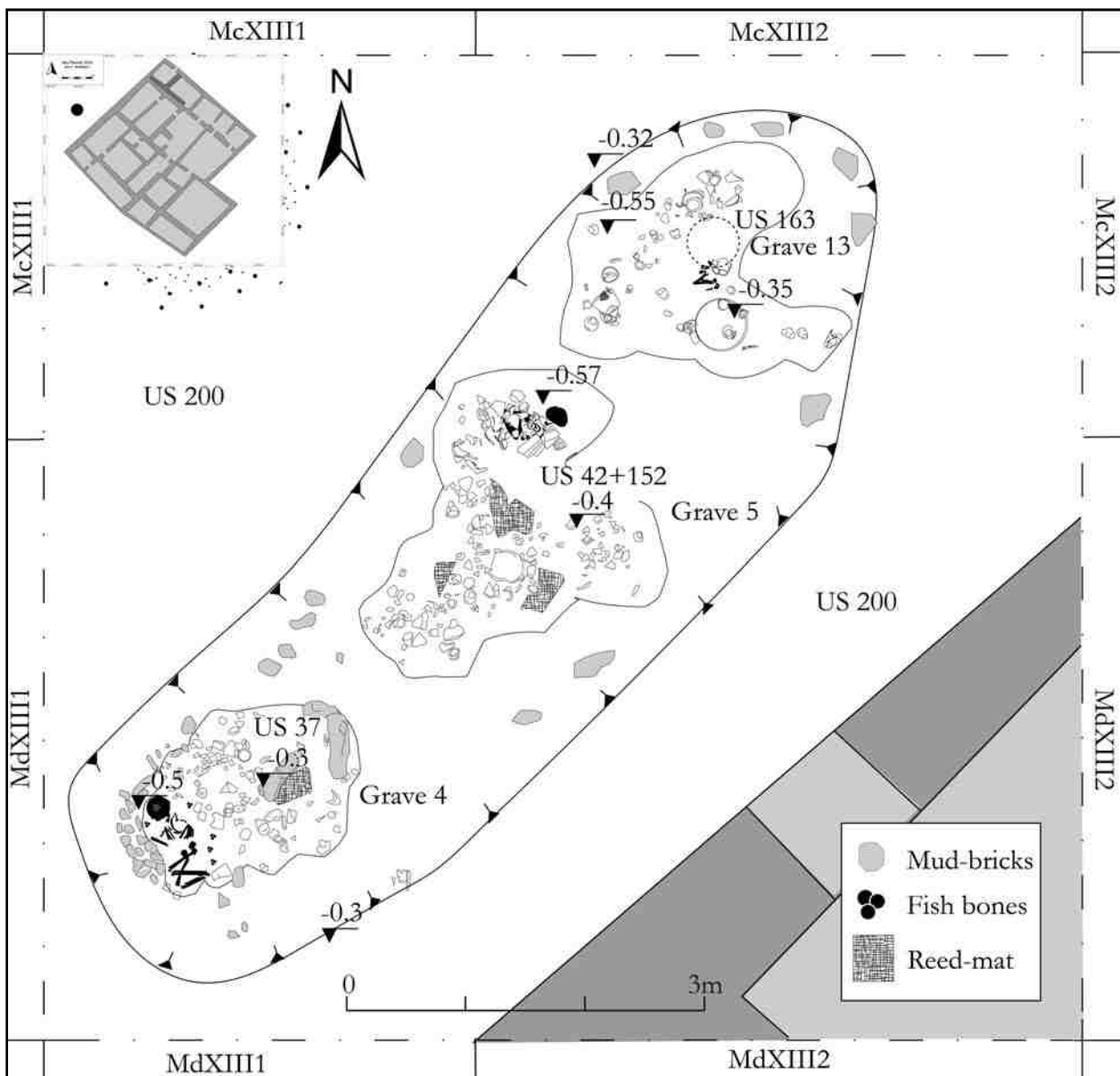

Fig. 8.106 Graves 4+5+13 plan.

position, the hips were opened outwards and the legs were not in connection.

In the north-eastern part of the grave, at the elevation of -0.54 m, the inhumation called Grave 13 was found with its equipment (US 163+166; Fig. 8.110). Only the lower part of the body was preserved. It was not possible to identify any sign of the presence of a cut or of any action following the inhumation: it is thus not clear if the lower part of the body was deposited there directly (so Grave 13 should be considered as secondary inhumation), though it is more probable that the upper part was removed later.⁴⁷

The intention of realizing a deposition in the same grave is confirmed by the cut limits, by the mud-brick fragments that revet them and also by the similar elevation of the inhumed bodies and equipments. These three inhumations are characterized by the presence of the peculiar remains of funerary banquet(s) (several broken jars and drinking vessels, together with fish bones and other animal bones), a ritual practice different from those attested in the building and in the later Cemetery in the area. The three pottery concentrations will be described here together with the other findings.

⁴⁷ The absence of pottery north-west of the body and the conical bowl partially preserved seems to point towards this

hypothesis and to the presence of a cut not identified during the excavation.



Fig. 8.107 Graves 4 and 5 during 2012 excavation.

Grave 4 cluster (US 37; Fig. 8.111) was placed near the skeleton of a young individual whose age has been estimated around 7-8 years. The skeleton and the pottery equipment were covered by reed-mat, the traces of which were found all over the surface. Some mud-bricks were placed over the mat aiming both at avoiding any dispersion of the furniture and, apparently, at separating the cluster from that of Grave 5. Grave 4 had at least 56 drinking vessels, 7 medium jars, 1 coarse big vessel, 1 cylinder and 1 big bowl, as well as several remains of animal and fish bones, possibly traces of a funerary banquet and of offerings. One of the drinking vessels, a beaker, found entirely preserved, was placed near the feet of the deceased (Area H).⁴⁸ The north-eastern part of the cluster, maintained in place by the mud-bricks, contained the highest number of drinking vessels fragments and of jars.

Grave 5 pottery concentration (US 42+152; Fig. 8.112) was covered by a reed-mat in its central part. It was considerably richer if compared to the previous one, being formed by at least 127 drinking vessels, 2 trays, 1 big bowl, 1 stemmed-dish, 17 jars of small and medium dimensions, 4 big dimension jars/containers.⁴⁹ Two lapis-lazuli beads from Grave 5, were recovered one in the sieved soil and the other *in situ*, close to the

⁴⁸ Two chert blades, two carnelian fragments, a grindstone, a circular bitumen object and a fragment of a big shell were in Grave 4 cluster.

⁴⁹ The pottery in the catalogue is only a part of that recovered. The total amount of entire shapes has been calculated considering only the bases preserved, thus the total number should be considered as the minimum of entire shapes in the Grave. As far as the stemmed dishes and big bowls are concerned, it is often difficult to distinguish between the two shapes (see § 10).



Fig. 8.108 Grave 4.

northern section of 2012 excavation.⁵⁰ As far as the distribution of the vessel fragments inside the grave is concerned (Fig. 8.112),⁵¹ most of the drinking vessels were located in the south-west part of the concentration (areas B and D) with a dispersion towards east (area C). Over the skeleton (area A) there were also several coarse pottery walls with applied ridges, the outer surface of which was covered by bitumen. In general, it seems that most of the jars were discarded in the areas A, B and C.

Grave 13 pottery was collected differently, due to the apparently circular deposition pattern (see Fig. 8.113). The concentration contained at least 91 drinking vessels, most of them in the area around the body (K - Fig. 8.113), 14 jars, 2 cylindrical vases and 6 big bowls and stemmed-dishes. In addition to these vessels, near the body, there was a big bitumen painted jar in fragments (AbT.13.163.28) with 11 drinking vessels inside. A carnelian fragment and a copper-alloy one were found together with a fragmentary clay chariot wheel. Fig. 8.113 shows the distribution of the vessels inside the cluster of Grave 13. Most of the pottery, mainly drinking vessels and jars fragments, was collected in area K, with the exception of few drinking vessels located east of jar AbT.13.163.29. The entire conical bowl AbT.13.163.22 was located east of the pelvis.

⁵⁰ A carnelian fragment, a chert flake and a white pebble were found in Grave 5 cluster.

⁵¹ All the fragments recovered were considered. The empty space in the grave (Fig. 8.105) is due to the partial collapse of the section in that point during 2012 winter rain-falls.



Fig. 8.109 Grave 5.



Fig. 8.110 Grave 13.

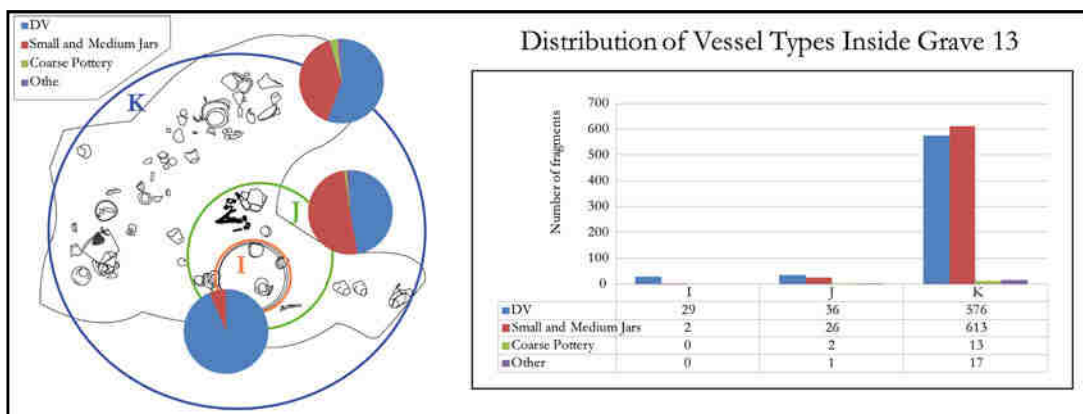
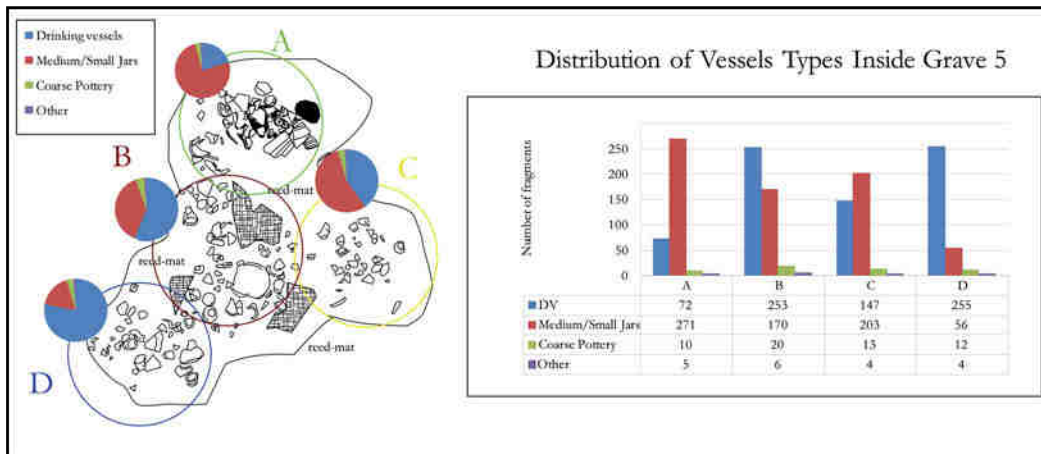
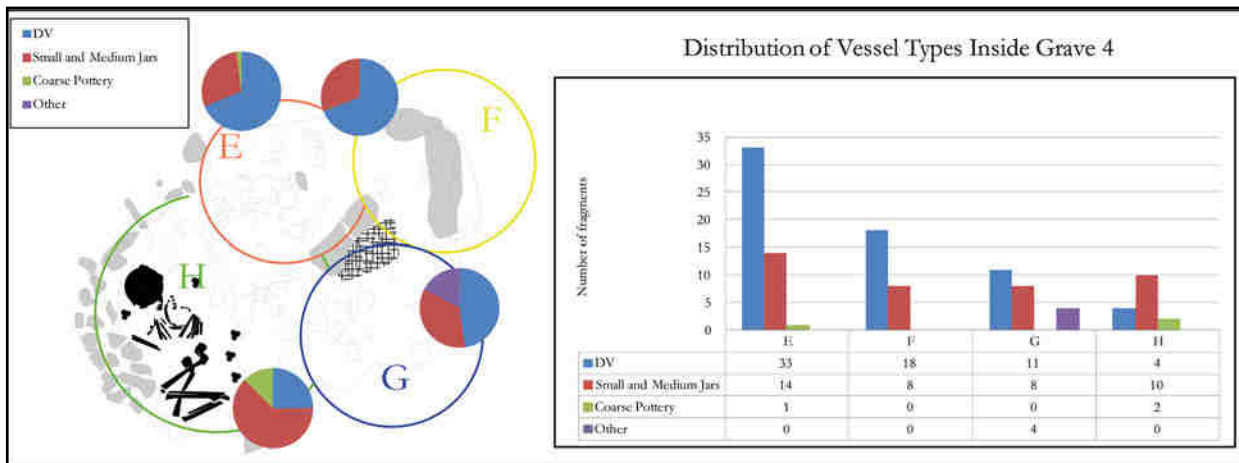

Figs 8.111-113 Grave 4+5+13. Distribution of pottery fragments.

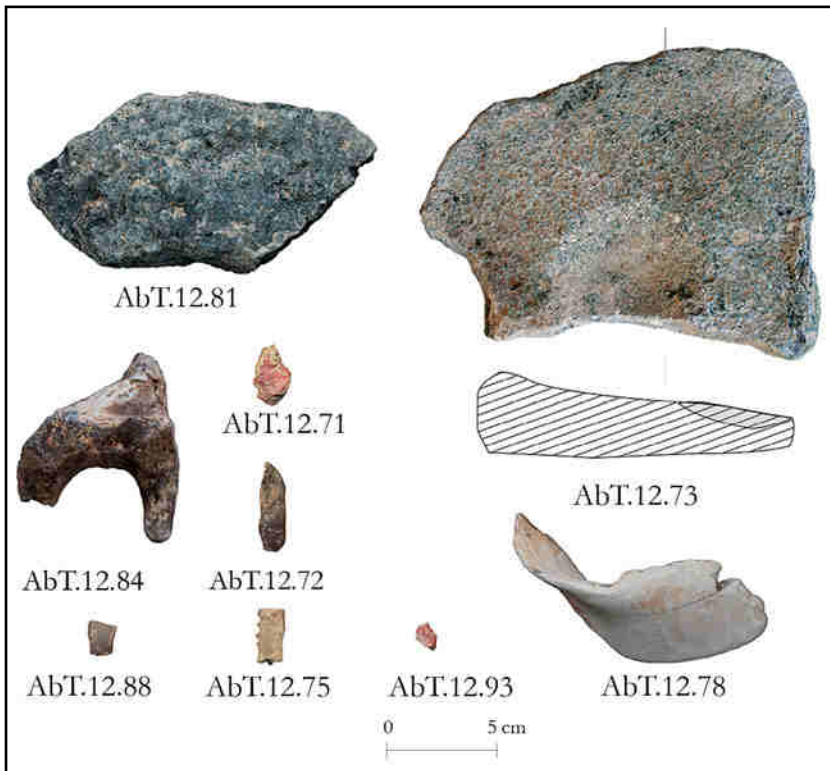

Fig. 8.114 US 37 objects.

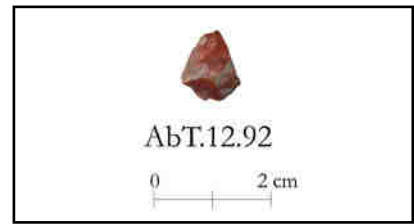

Fig. 8.115 US 32 objects.



Fig. 8.117 US 42 objects.

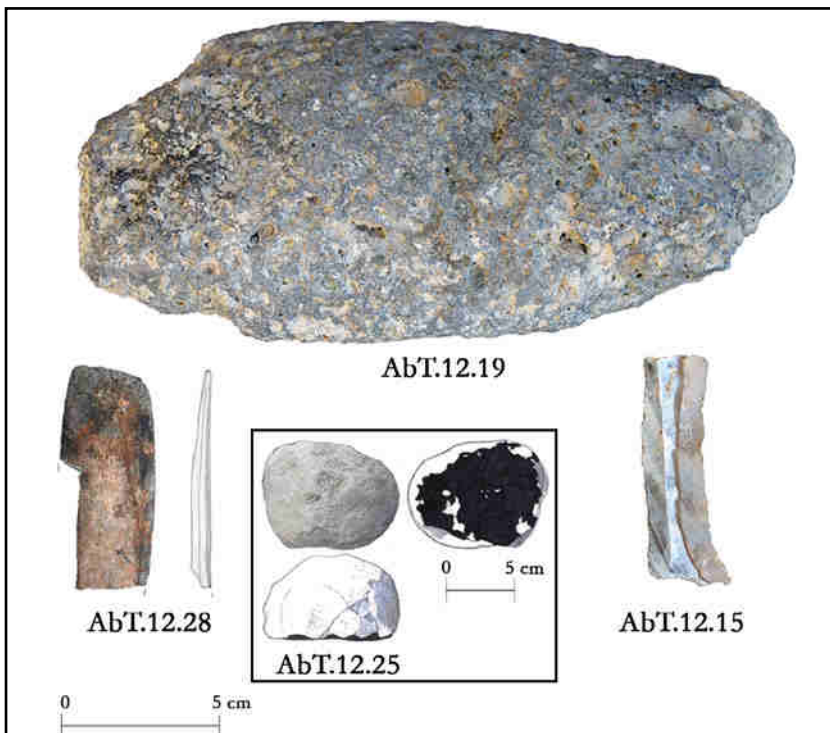

Fig. 8.116 US 38 objects.



Fig. 8.118 US 134 objects.



Fig. 8.119 US 152 objects.

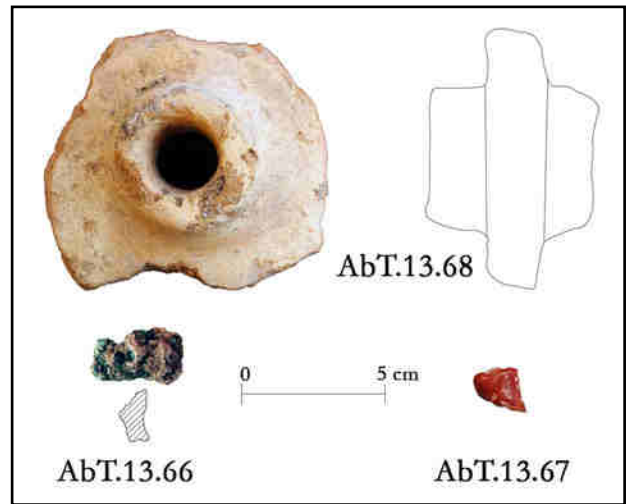

Fig. 8.120 US 163 objects.



Fig. 8.121 US 166 objects.

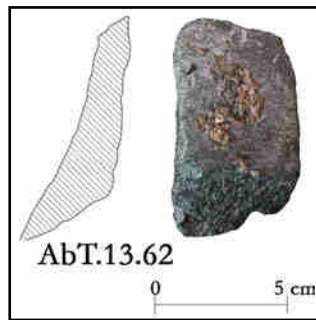

Fig. 8.122 US 167 objects.



Fig. 8.123 US 200 objects.

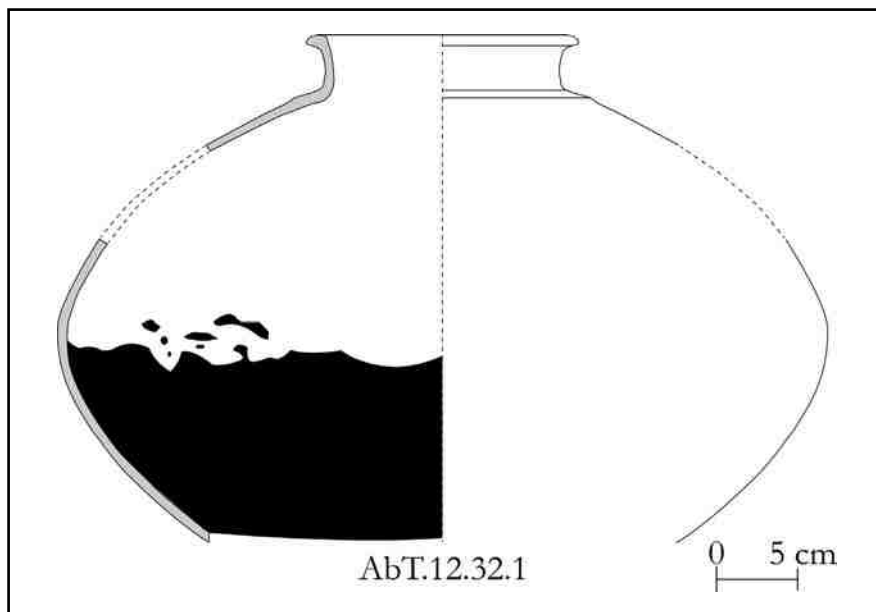

Fig. 8.124 US 32 pottery.

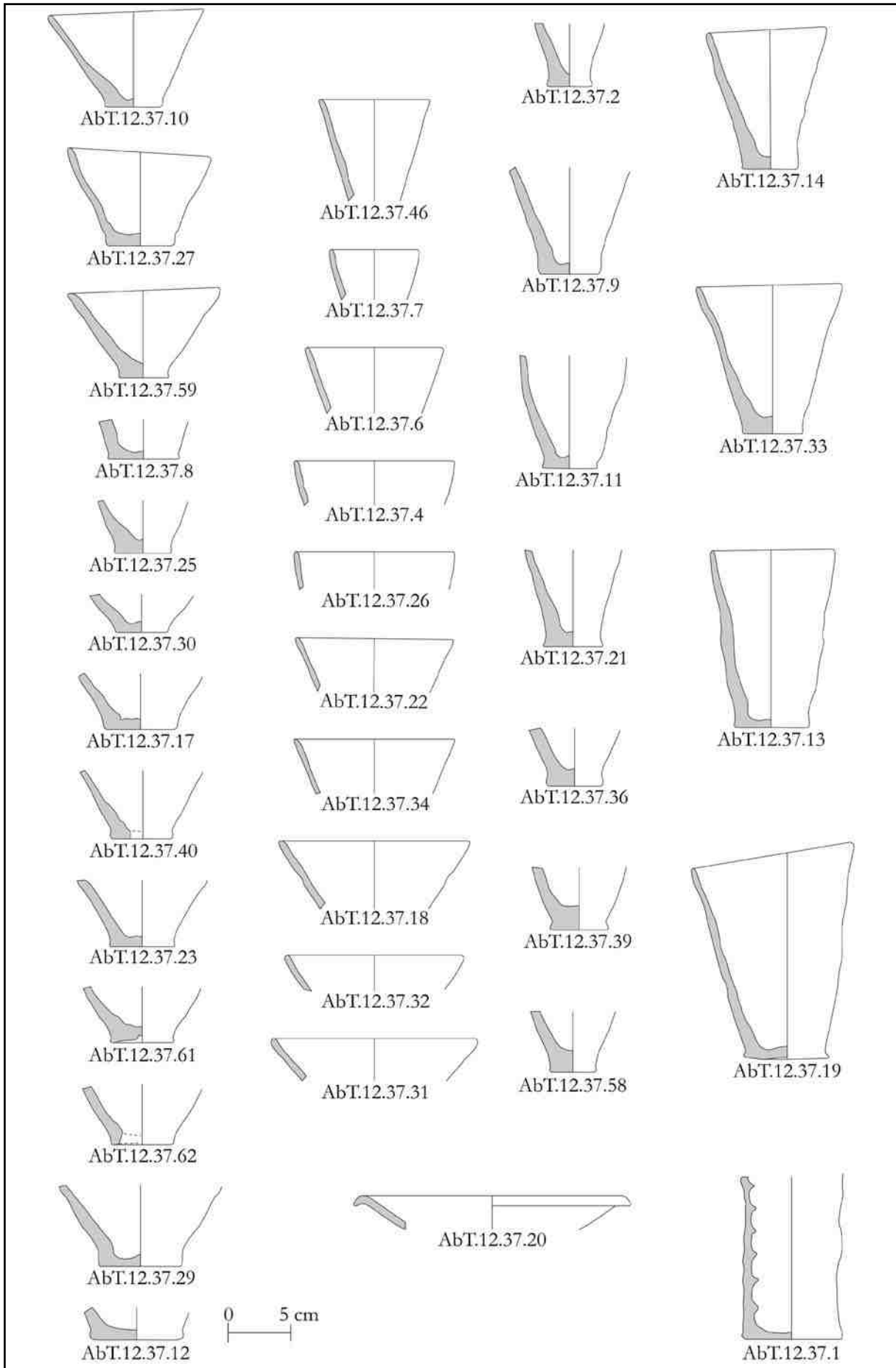

Fig. 8.125 US 37 pottery: open shapes.

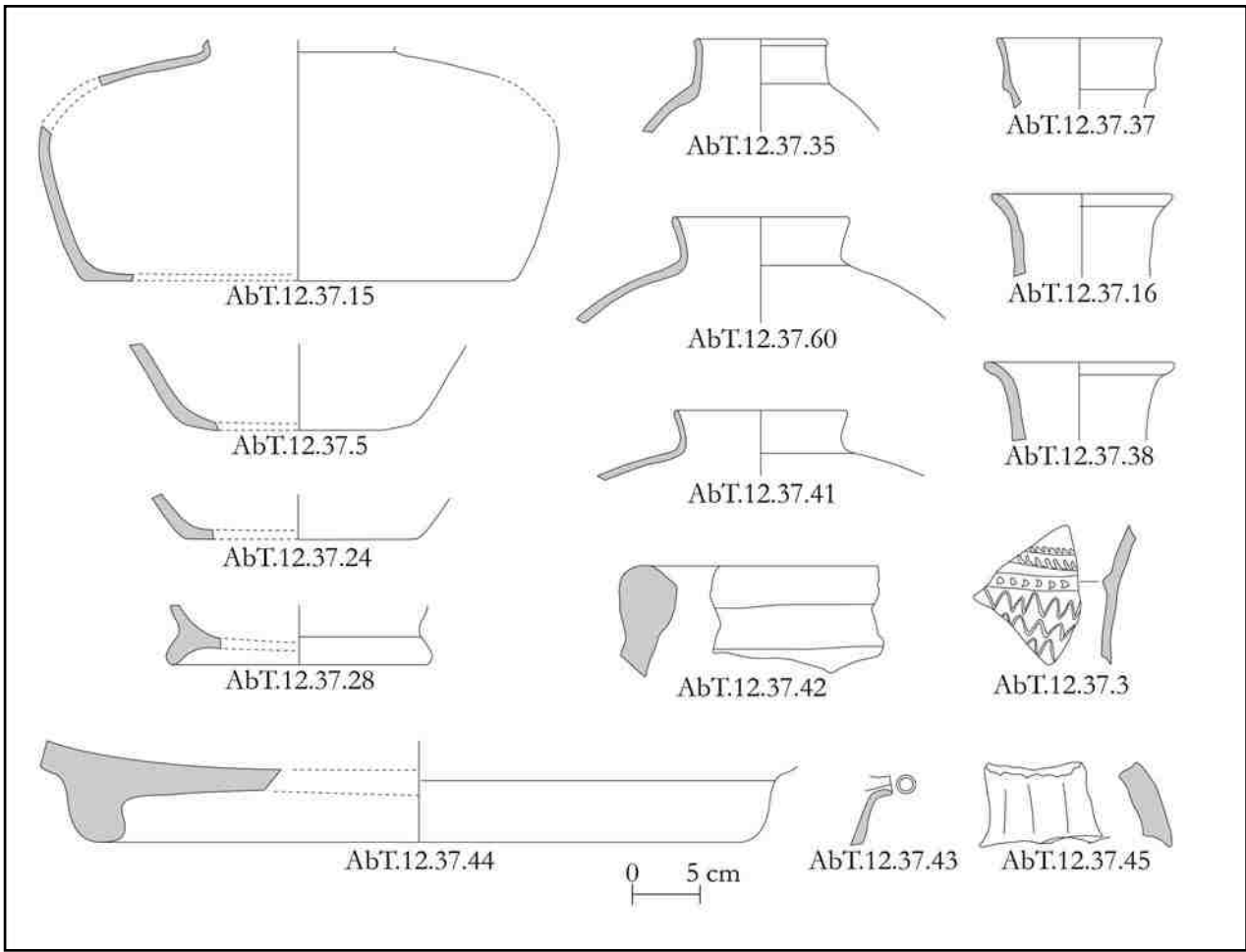

Fig. 8.126 US 37 pottery: closed and other shapes.

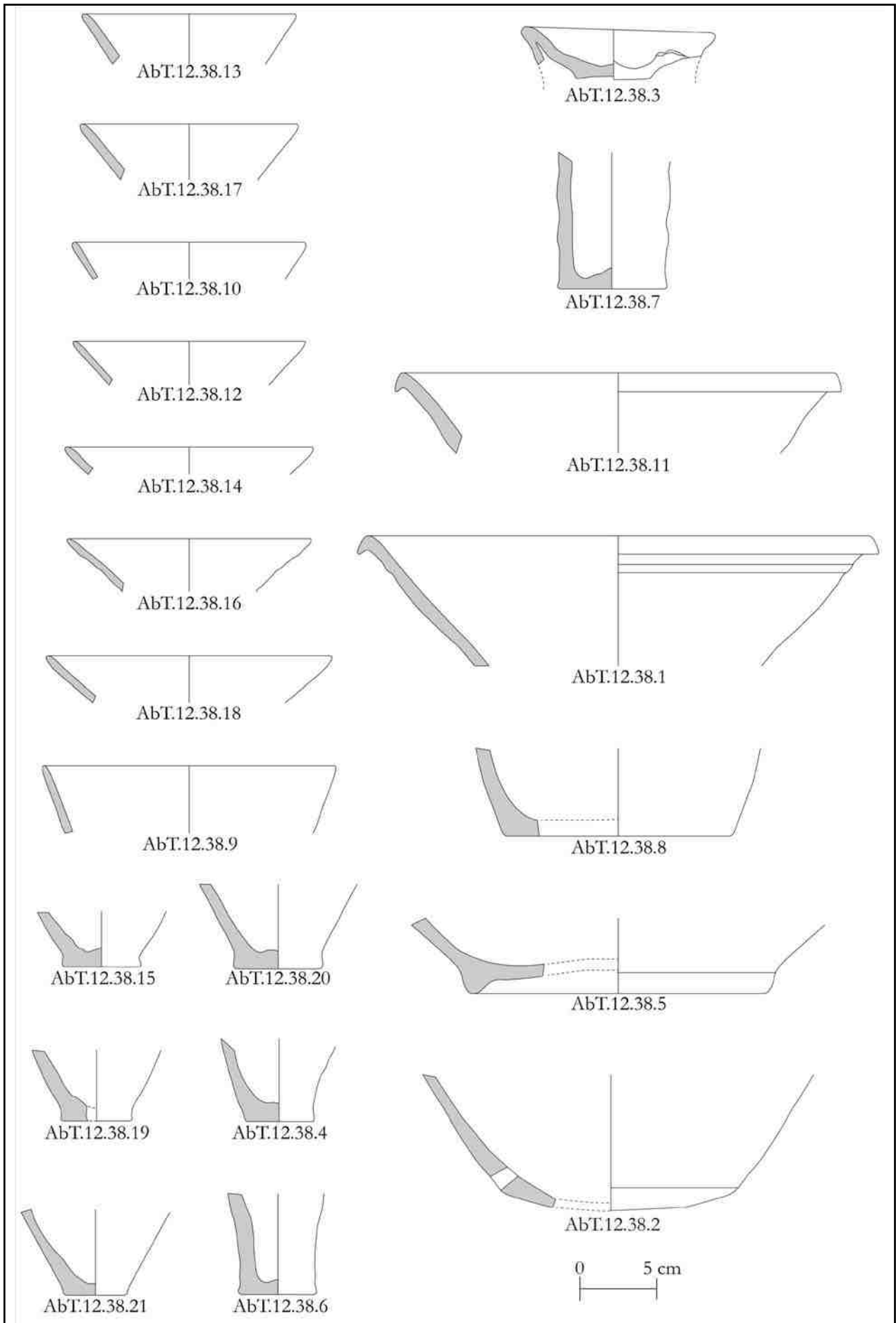

Fig. 8.127 US 38 pottery.

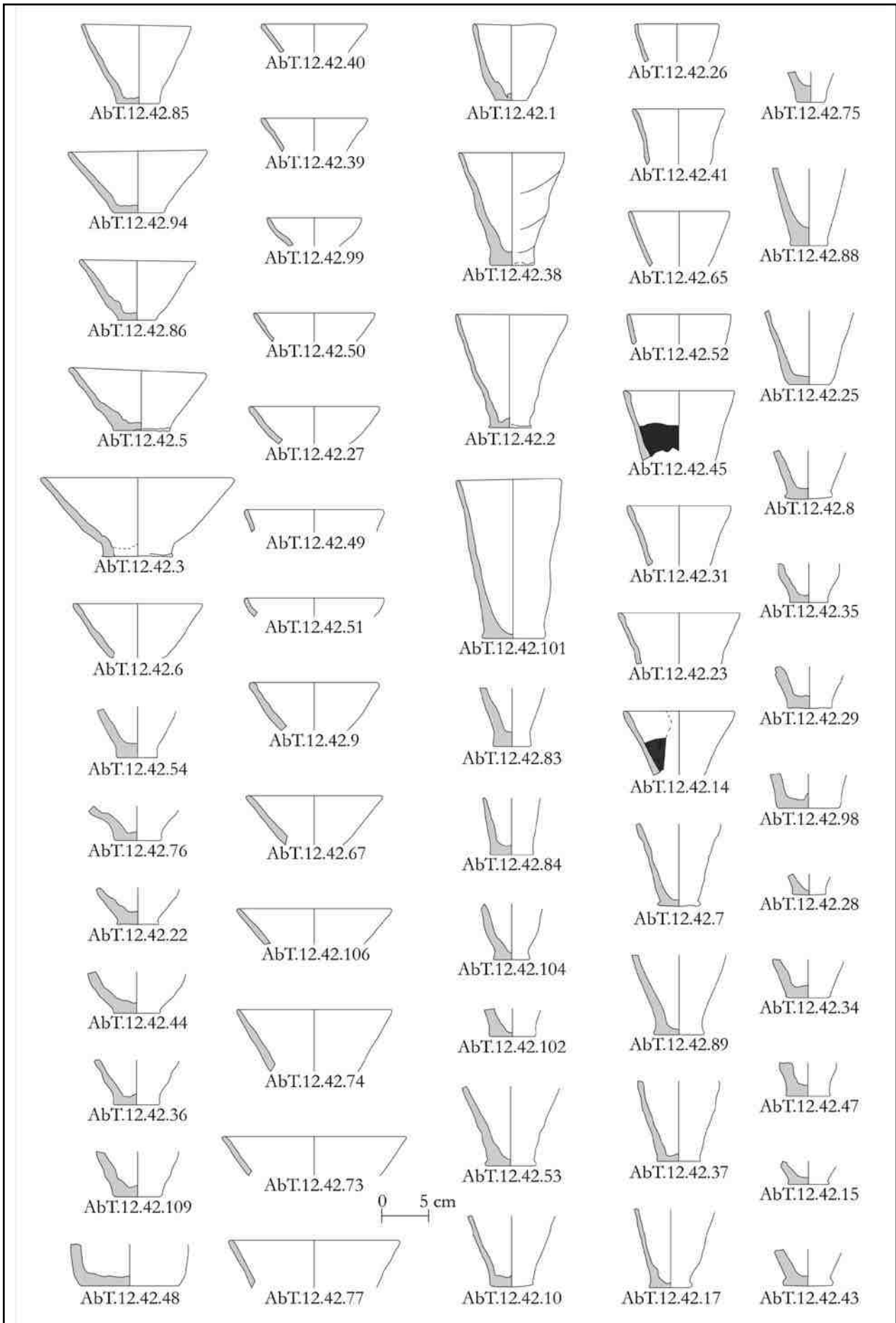

Fig. 8.128 US 42 pottery.

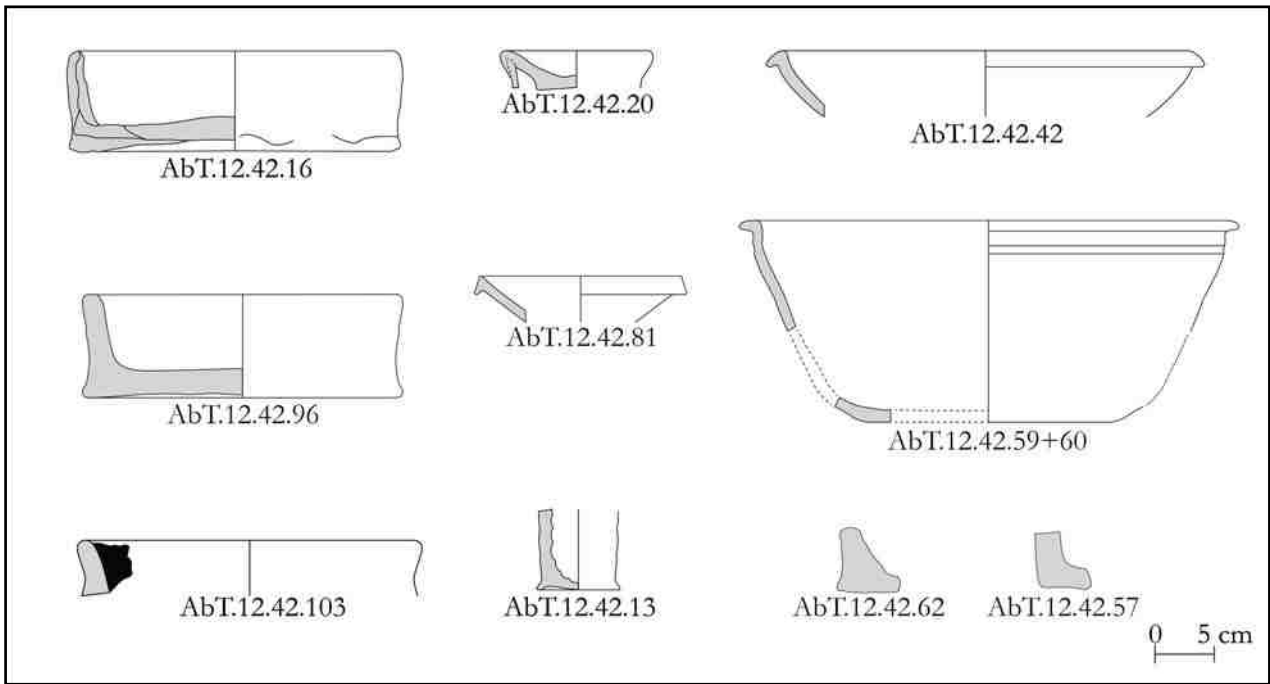

Fig. 8.129 US 42 pottery: open shapes (2).

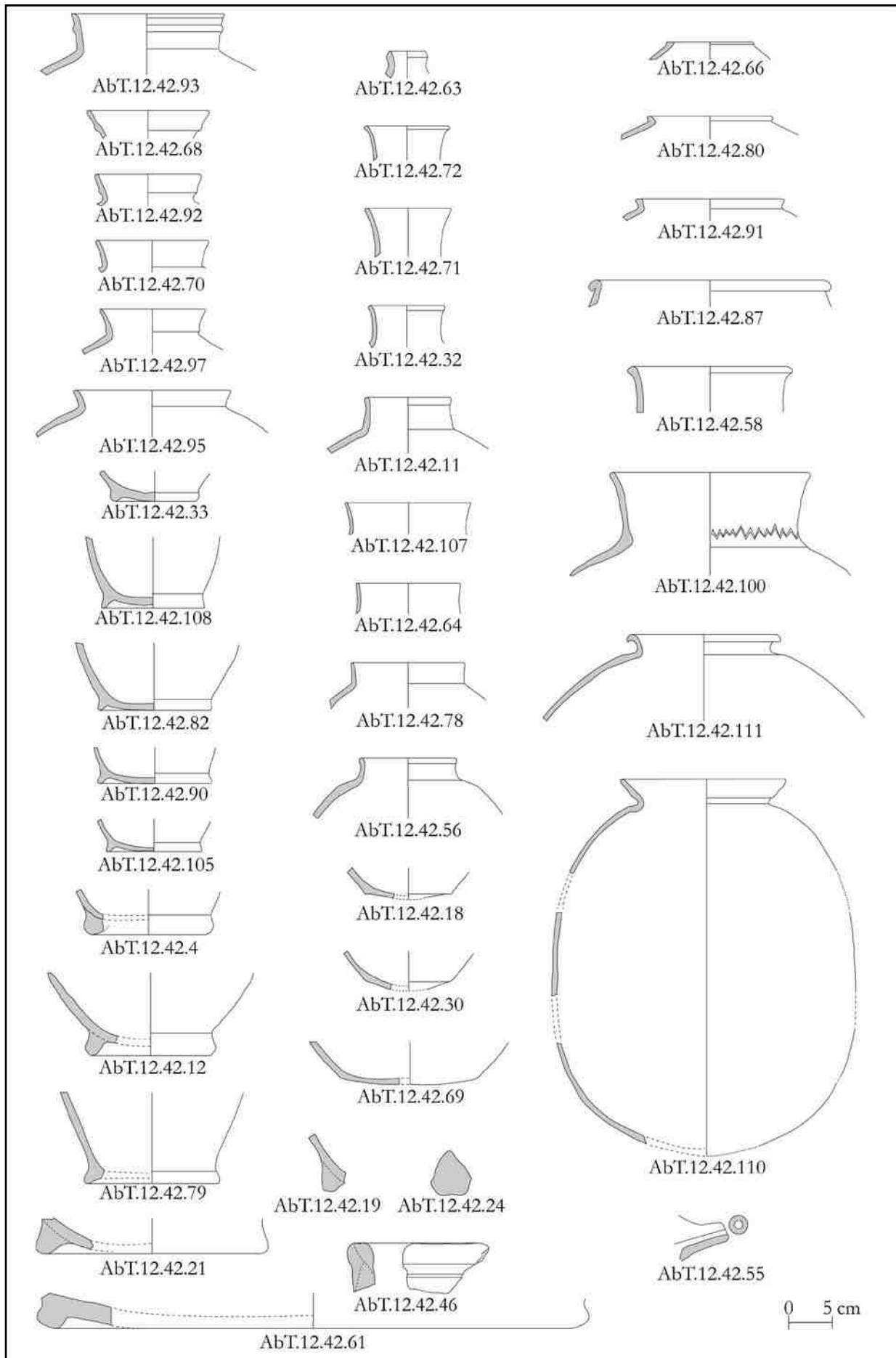

Fig. 8.130 US 42 pottery: closed shapes.

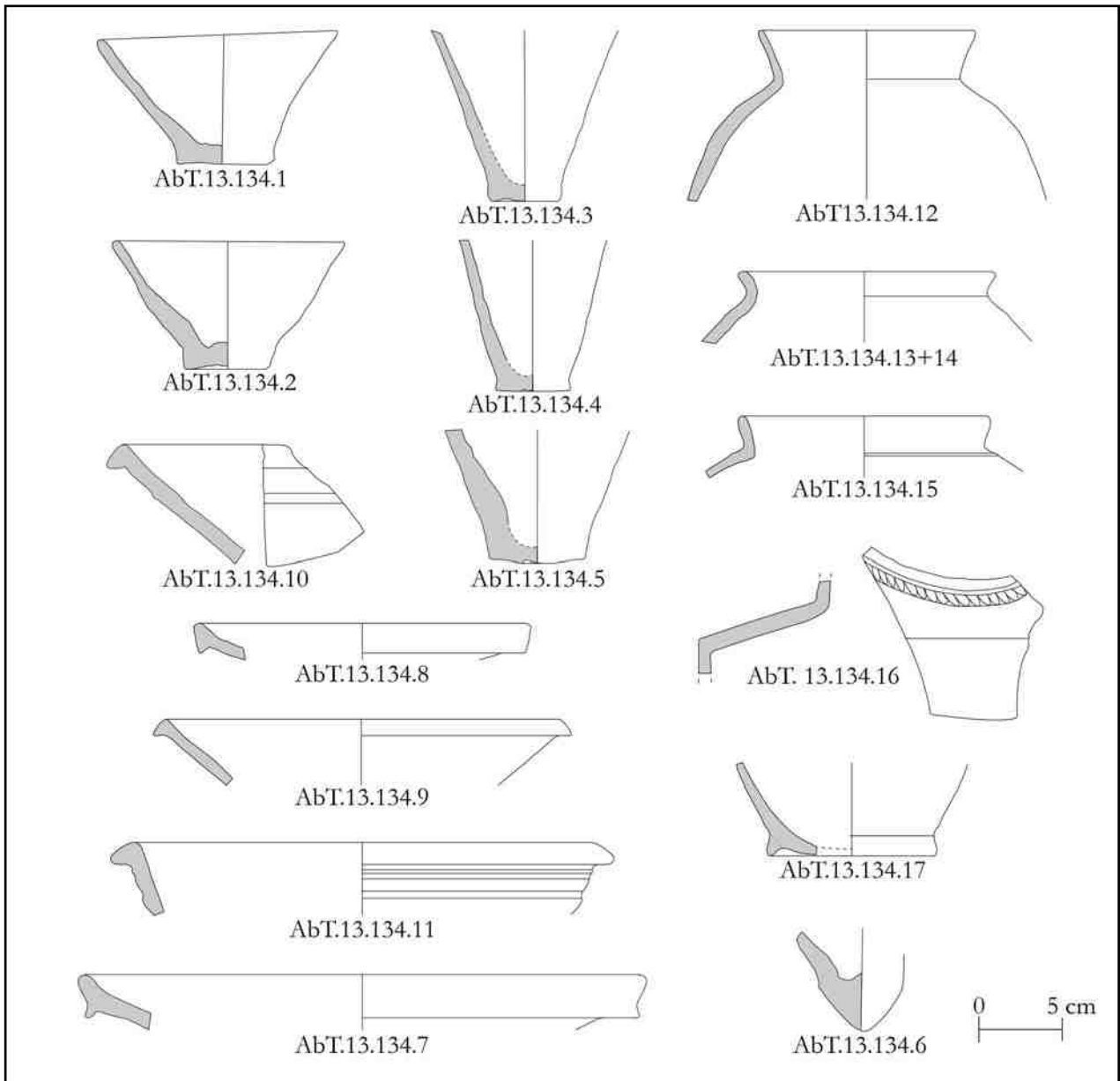

Fig. 8.131 US 134 pottery.

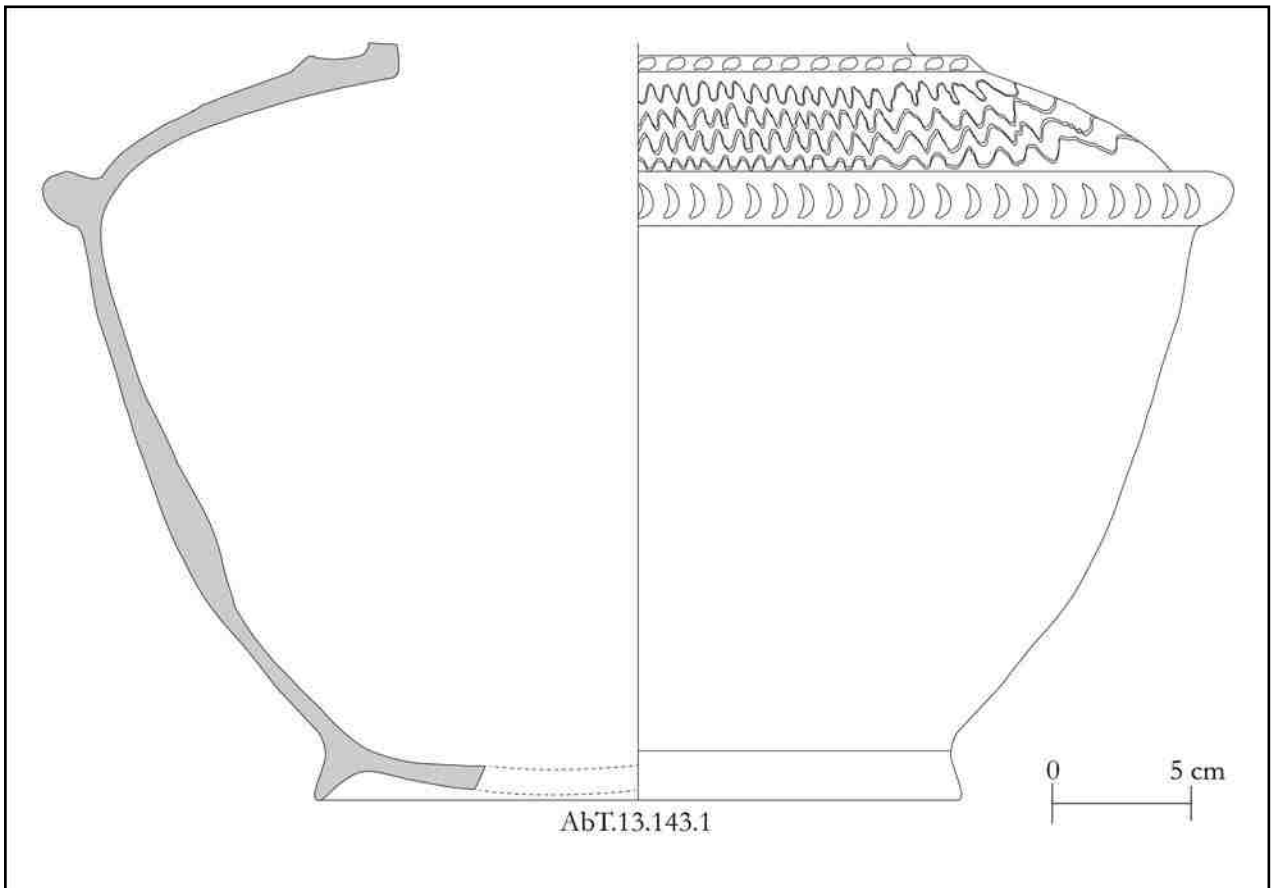

Fig. 8.132 US 143 pottery.

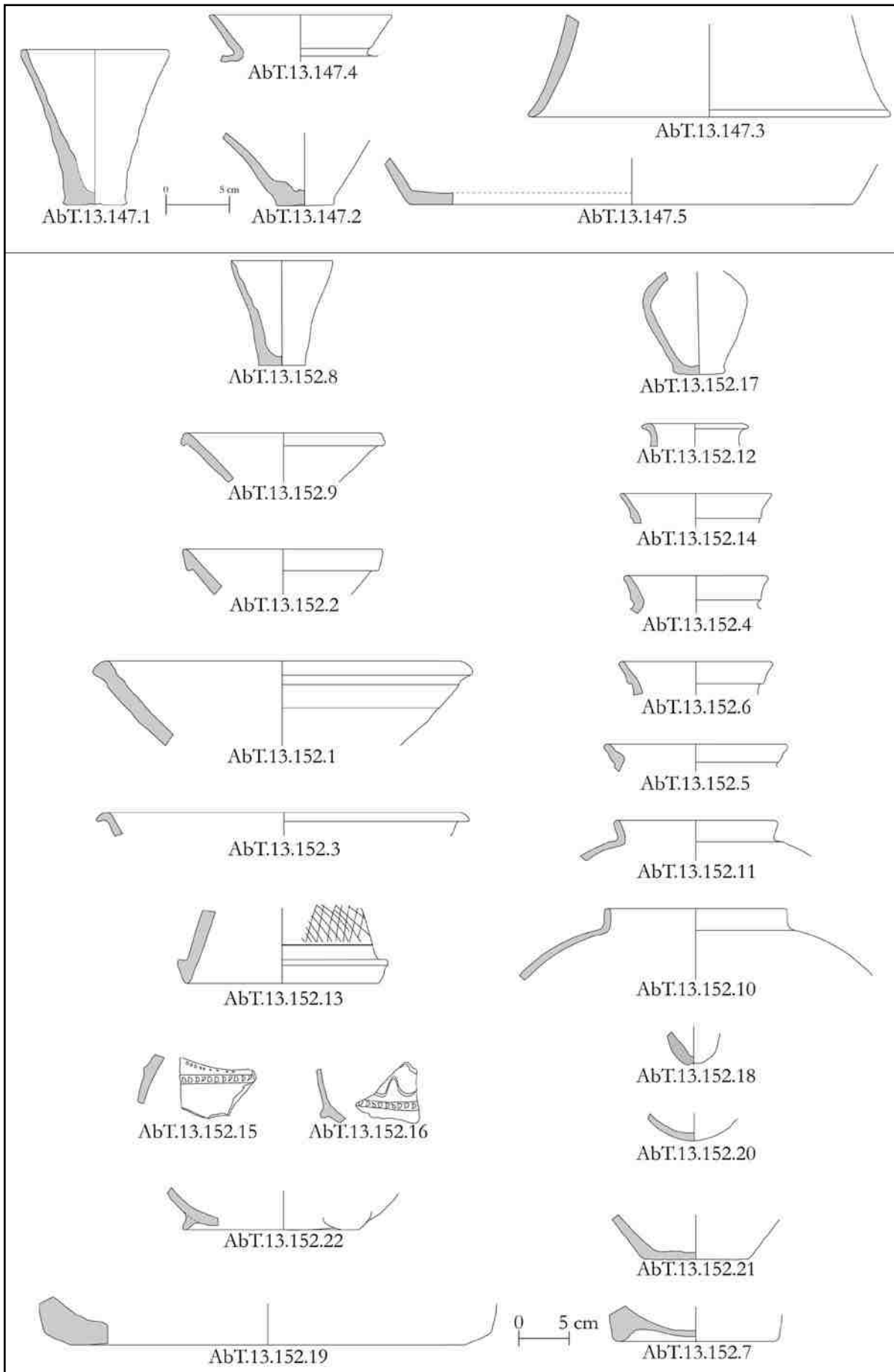

Fig. 8.133 US 147 and US 152 pottery.

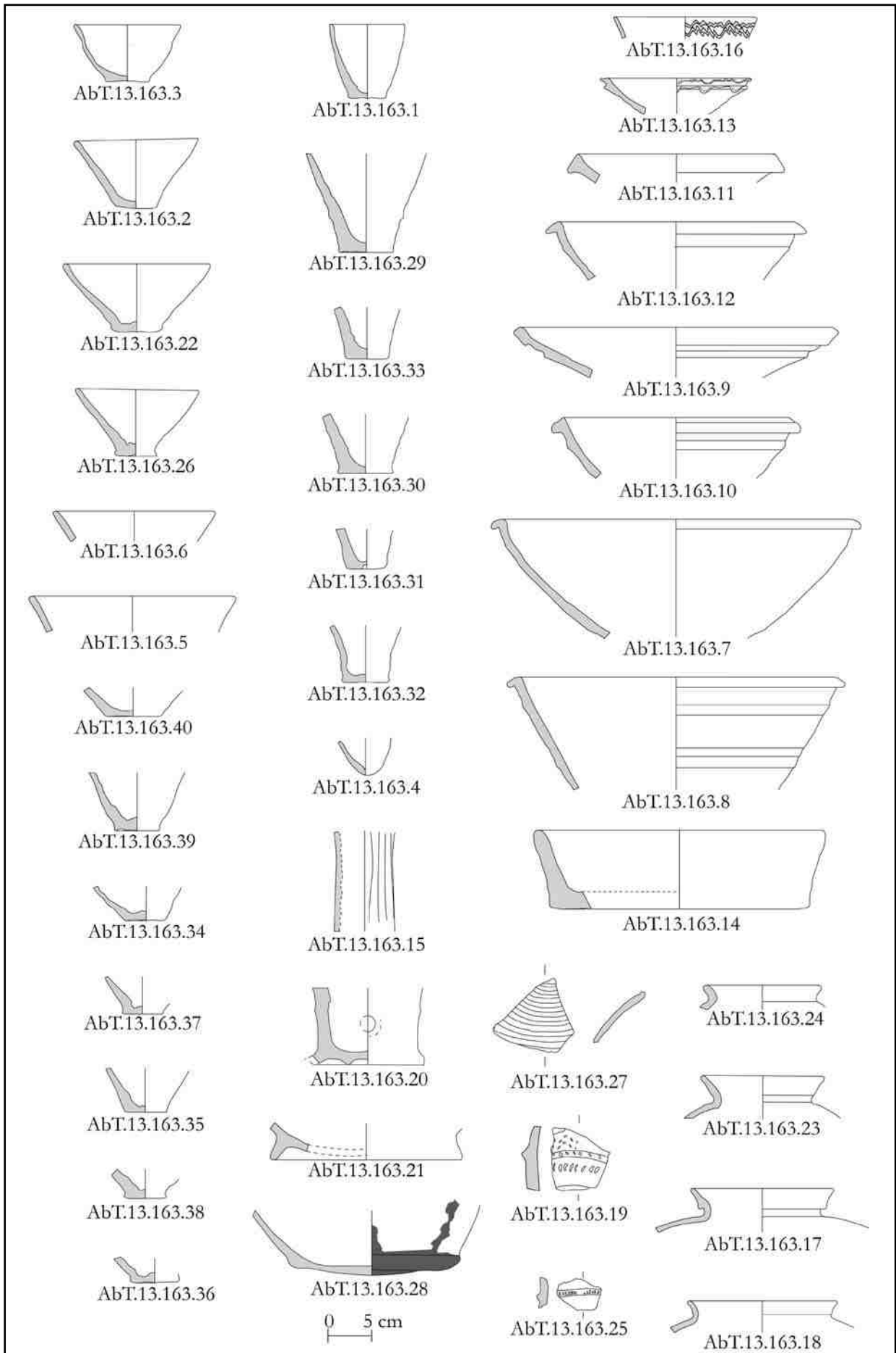

Fig. 8.134 US 163 pottery.

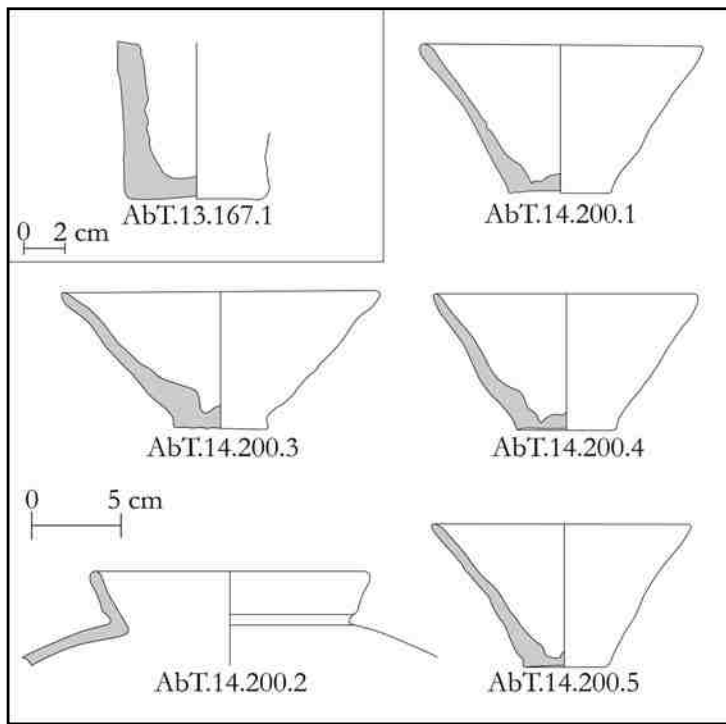

Fig. 8.135 US 167 and US 200 pottery.

Catalogue of US 32 Finds

*Objects***AbT.12.92 - Fig. 8.115**

Description: carnelian fragment.
Dimensions: 1x0.8x0.6 cm.

*Pottery***AbT.12.32.1 - Fig. 8.130**

Dimensions: rim diam.: 15 cm; rim th.: 1.3 cm; wall th.: 0.5 cm.
Clay: outer, inner, fabric colour: 2.5Y 7/3 (pale brown); sand inclusions; medium firing temperature.
Description: triangular rim jar.

Catalogue of US 37 Finds⁵²*Objects***AbT.12.71 - Fig. 8.114**

Description: carnelian fragment.
Dimensions: 2x1 cm.

AbT.12.72 - Fig. 8.114

Description: chert blade.
Dimensions: 4x1 cm.

AbT.12.73 - Fig. 8.114

Description: grindstone with bitumen traces. [SC]
Dimensions: 18x15x3 cm.

AbT.12.75 - Fig. 8.114

Description: chert sickle element.
Dimensions: 2x1 cm.

AbT.12.78 - Fig. 8.114

Description: shell fragment.
Dimensions: 6x2 cm.

AbT.12.81 - Fig. 8.114

Description: bitumen object fragment.
Dimensions: 10 ca.x5x1 cm.

AbT.12.84 - Fig. 8.114

Description: animal clay figurine fragment.
Dimensions: 3x3x4 cm.

AbT.12.88 - Fig. 8.114

Description: chert blade.
Dimensions: 1x1 cm.

AbT.12.93 - Fig. 8.114

Description: carnelian fragment.
Dimensions: 0.8x0.3x0.3 cm.

*Pottery***AbT.12.37.1 - Fig. 8.125**

Dimensions: wall th.: 1 cm; base diam.: 8 cm; base th.: 0.6 cm.
Clay: outer, inner and fabric colour: not registered; sand inclusions; medium-low firing temperature.
Description: cylinder.

AbT.12.37.2 - Fig. 8.125

Dimensions: base diam.: 3.7 cm; base th.: 1 cm.
Clay: outer and inner colour: 5YR 7/6 (reddish yellow); fabric colour: 2.5YR 5/6 (red); sand inclusions; medium-high firing temperature.
Description: beaker base.

AbT.12.37.3 - Fig. 8.126

Dimensions: wall th.: 1 cm.
Clay: outer, inner and fabric colour: 5Y 6/3 (pale olive); sand inclusions; high firing temperature.
Description: wall fragment with 3 lines of incised decorations followed by a notched ridge and two lines of oblique incisions.

AbT.12.37.4 - Fig. 8.125

Dimensions: rim diam.: 13.4 cm; rim th.: 0.4 cm; wall th.: 0.5 cm.
Clay: outer, inner and fabric colour: 2.5Y 7/4 (pale yellow); sand inclusions; medium-high firing temperature.
Description: drinking vessel rim.

AbT.12.37.5 - Fig. 8.26

Dimensions: wall th.: 1 cm; base diam.: 18.6 cm; base th.: 0.7 cm.
Clay: outer and inner colour: 7.5YR 5/4 (brown); fabric colour: 10YR 5/6 (yellowish brown); sand inclusions; medium-high firing temperature.
Description: flat base.

AbT.12.37.6 - Fig. 8.125

Dimensions: rim diam.: 11 cm; rim th.: 0.4 cm; wall th.: 0.5 cm.
Clay: outer and inner colour: 10YR 7/6 (yellow); fabric colour: 5YR 6/6

(reddish yellow); sand inclusions; medium-high firing temperature.
Description: drinking vessel rim.

AbT.12.37.7 - Fig. 8.125

Dimensions: rim diam.: 7.6 cm; rim th.: 0.4 cm; wall th.: 0.5 cm.
Clay: outer, inner and fabric colour: 5YR 6/6 (reddish yellow); sand inclusions; medium-high firing temperature.
Description: drinking vessel rim.

AbT.12.37.8 - Fig. 8.125

Dimensions: wall th.: 1 cm; base diam.: 6 cm; base th.: 0.6 cm.
Clay: outer, inner and fabric colour: 10YR 7/6 (yellow); sand inclusions; medium-high firing temperature.
Description: conical bowl base.

AbT.12.37.9 - Fig. 8.125

Dimensions: wall th.: 0.8 cm; base diam.: 4.8 cm; base th.: 0.9 cm.
Clay: outer, inner and fabric colour: 10YR 6/4 (light yellowish brown); sand inclusions; medium-high firing temperature.
Description: beaker base.

AbT.12.37.10 - Fig. 8.125

Dimensions: rim diam.: 12.8 cm; rim th.: 0.5 cm; wall th.: 0.8 cm; base diam.: 4.5 cm; base th.: 0.7 cm; h.: 8.1 cm.
Clay: outer, inner and fabric colour: 5YR 6/6 (reddish yellow); sand inclusions; medium firing temperature.
Description: conical bowl.

AbT.12.37.11 - Fig. 8.125

Dimensions: wall th.: 0.6 cm; base diam.: 4.5 cm; base th.: 1 cm.
Clay: outer, inner, fabric colour: 5YR 4/6 (yellowish red); sand inclusions; medium firing temperature.
Description: beaker base.

AbT.12.37.12 - Fig. 8.125

Dimensions: wall th.: 0.9 cm; base diam.: 7 cm; base th.: 0.8 cm.
Clay: outer, inner, fabric colour: 5YR 4/6 (yellowish red); sand inclusions; medium firing temperature.
Description: conical bowl base.

AbT.12.37.13 - Fig. 8.125

Dimensions: rim diam.: 10 cm; rim th.: 0.4 cm; wall th.: 1 cm; base diam.: 6 cm; base th.: 0.7 cm; h.: 14.7 cm.
Clay: outer and inner colour: 2.5YR 4/6 (red); fabric colour: 5YR 7/8 (reddish

⁵² The numeration of US 37 pottery is not complete because some of the pottery fragments originally attributed to this US were moved to US 38.

yellow); sand inclusions; medium-high firing temperature.
Description: beaker.

AbT.12.37.14 - Fig. 8.125

Dimensions: rim diam.: 9.9 cm; rim th.: 0.5 cm; wall th.: 0.9 cm; base diam.: 4.5 cm; base th.: 1 cm; h.: 11.7 cm.

Clay: outer, inner and fabric colour: 2.5Y 6/3 (light yellowish brown); sand inclusions; high firing temperature.

Description: beaker.

AbT.12.37.15 - Fig. 8.126

Dimensions: wall th.: 0.8 cm; base diam.: 32.5 cm; base th.: 0.5 cm.

Clay: outer and inner colour: 5YR 6/6 (reddish yellow); fabric colour: 2.5YR 5/6 (red); sand inclusions; medium firing temperature.

Description: base and wall of a squat jar (reconstructed graphically).

AbT.12.37.16 - Fig. 8.126

Dimensions: rim diam.: 13 cm; rim th.: 0.6 cm; wall th.: 0.8 cm.

Clay: outer, inner and fabric colour: 5YR 4/4 (reddish brown); sand inclusions; medium-high firing temperature.

Description: plain rim jar.

AbT.12.37.17 - Fig. 8.125

Dimensions: wall th.: 0.6 cm; base diam.: 5.8 cm; base th.: 0.8 cm.

Clay: outer colour: 10YR 6/4 (brown yellow); inner colour: 2.5Y 6/4 (light yellowish brown); fabric colour: 5YR 5/6 (yellowish red); sand inclusions; medium-high firing temperature.

Description: conical bowl base.

AbT.12.37.18 - Fig. 8.125

Dimensions: rim diam.: 16 cm; rim th.: 0.8 cm; wall th.: 0.5 cm.

Clay: outer colour: 10YR 6/6 (brownish yellow); inner and fabric colour: 5YR 5/6 (yellowish red); sand inclusions; medium firing temperature.

Description: drinking vessel rim.

AbT.12.37.19 - Fig. 8.125

Dimensions: rim diam.: 13.4 cm; rim th.: 0.5 cm; wall th.: 0.8 cm; base diam.: 6.8 cm; base th.: 0.8 cm; h.: 17.9 cm.

Clay: outer colour: 10YR 6/6 (brownish yellow); inner and fabric colour: 5YR 5/6 (yellowish red); sand inclusions; medium-high firing temperature.

Description: beaker.

AbT.12.37.20 - Fig. 8.125

Dimensions: rim diam.: 21.4 cm; rim th.: 1.9 cm; wall th.: 0.6 cm.

Clay: outer, inner and fabric colour: 2.5Y 7/4 (pale yellow); sand inclusions; medium-high firing temperature.

Description: triangular rim bowl.

AbT.12.37.21 - Fig. 8.125

Dimensions: wall th.: 0.9 cm; base diam.: 4.5 cm; base th.: 1.2 cm.

Clay: outer, inner and fabric colour: 2.5YR 5/6 (red); sand inclusions; medium-low firing temperature.

Description: beaker base.

AbT.12.37.22 - Fig. 8.125

Dimensions: rim diam.: 10.8 cm; rim th.: 0.5 cm; wall th.: 0.4 cm.

Clay: outer, inner and fabric colour: 10YR 5/6 (yellowish brown); sand inclusions; medium-high firing temperature.

Description: drinking vessel rim.

AbT.12.37.23 - Fig. 8.125

Dimensions: wall th.: 0.8 cm; base diam.: 5.2 cm; base th.: 0.8 cm.

Clay: outer, inner and fabric colour: 10YR 8/6 (yellow); sand inclusions; medium-high firing temperature.

Description: conical bowl base.

AbT.12.37.24 - Fig. 8.126

Dimensions: wall th.: 0.8 cm; base diam.: 17 cm; base th.: 0.7 cm.

Clay: outer, inner and fabric colour: 10YR 8/6 (yellow); sand inclusions; medium-high firing temperature.

Description: flat base jar.

AbT.12.37.25 - Fig. 8.125

Dimensions: wall th.: 0.5 cm; base diam.: 4.5 cm; base th.: 1.2 cm.

Clay: outer, inner and fabric colour: 5YR 5/6 (yellowish red); sand inclusions; medium-high firing temperature.

Description: beaker base.

AbT.12.37.26 - Fig. 8.125

Dimensions: rim diam.: 13 cm; rim th.: 0.3 cm; wall th.: 0.4 cm.

Clay: outer, inner and fabric colour: 2.5Y 7/4 (pale yellow); sand inclusions; medium-high firing temperature.

Description: drinking vessel rim.

AbT.12.37.27 - Fig. 8.125

Dimensions: rim diam.: 11.8 cm; rim th.: 0.5 cm; wall th.: 0.5 cm; base diam.: 5.5 cm; base th.: 1 cm; h.: 8.1 cm.

Clay: outer and inner colour: 10YR 7/4 (very pale brown); fabric colour: 5YR 6/6 (reddish yellow); sand inclusions; medium-high firing temperature.

Description: conical bowl.

AbT.12.37.28 - Fig. 8.126

Dimensions: wall th.: 0.7 cm; base diam.: 19 cm; base th.: 0.8 cm.

Clay: outer colour: 10YR 6/4 (light yellowish brown); inner and fabric colour: 5YR 6/8 (reddish yellow); sand inclusions; medium-high firing temperature.

Description: ring base.

AbT.12.37.29 - Fig. 8.125

Dimensions: wall th.: 1 cm; base diam.: 7 cm; base th.: 1 cm.

Clay: outer, inner and fabric colour: 2.5YR 5/6 (red); sand inclusions; medium-high firing temperature.

Description: conical bowl base.

AbT.12.37.30 - Fig. 8.125

Dimensions: wall th.: 0.7 cm; base diam.: 4.2 cm; base th.: 0.9 cm.

Clay: outer, inner and fabric colour: 5YR 6/6 (reddish yellow); sand inclusions; medium-high firing temperature.

Description: conical bowl base.

AbT.12.37.31 - Fig. 8.125

Dimensions: rim diam.: 16.6 cm; rim th.: 0.6 cm; wall th.: 0.5 cm.

Clay: outer, inner and fabric colour: 2.5Y 7/6 (yellow); sand inclusions; medium-high firing temperature.

Description: drinking vessel rim.

AbT.12.37.32 - Fig. 8.125

Dimensions: rim diam.: 14.4 cm; rim th.: 0.5 cm; wall th.: 0.5 cm.

Clay: outer, inner and fabric colour: 5YR 7/6 (reddish yellow); sand inclusions; medium-high firing temperature.

Description: drinking vessel rim.

AbT.12.37.33 - Fig. 8.125

Dimensions: rim diam.: 11.9 cm; rim th.: 0.4 cm; wall th.: 0.9 cm; base diam.: 4.6 cm; base th.: 1.5 cm; h.: 12.4 cm.

Clay: outer, inner and fabric colour: 2.5YR 5/8 (red); sand inclusions; low firing temperature.

Description: beaker.

AbT.12.37.34 - Fig. 8.125

Dimensions: rim diam.: 13.2 cm; rim th. 0.4; wall th.: 0.3 cm.

Clay: outer, inner and fabric colour: 7.5YR 6/6 (reddish yellow); sand inclusions; medium-low firing temperature.

Description: drinking vessel rim.

AbT.12.37.35 - Fig. 8.126

Dimensions: rim diam.: 9.4 cm; rim th.: 0.5 cm; wall th.: 0.1 cm.

Clay: outer, inner and fabric colour: 5Y 7/3 (pale yellow); sand inclusions; medium-high firing temperature.

Description: plain rim jar.

AbT.12.37.36 - Fig. 8.125

Dimensions: wall th.: 1 cm; base diam.: 4.5 cm; base th.: 1.4 cm.

Clay: outer, inner and fabric colour: 5YR 4/6 (yellowish red); sand inclusions; medium-high firing temperature.

Description: beaker base.

AbT.12.37.37 - Fig. 8.126

Dimensions: rim diam.: 12 cm; rim th.: 0.4 cm; wall th.: 0.4 cm.

Clay: outer, inner and fabric colour: 10YR 6/4 (light yellowish brown); sand inclusions; medium-high firing temperature.

Description: band rim jar.

AbT.12.37.38 - Fig. 8.126

Dimensions: rim diam.: 13.6 cm; rim th.: 0.8 cm; wall th.: 0.9 cm.

Clay: outer, inner and fabric colour: 5YR 6/6 (reddish yellow); sand inclusions; medium firing temperature.

Description: plain rim jar.

AbT.12.37.39 - Fig. 8.125

Dimensions: wall th.: 0.9 cm; base diam.: 4.5 cm; base th.: 1.9 cm.

Clay: outer, inner and fabric colour: 2.5YR 6/8 (red); sand inclusions; low firing temperature.

Description: beaker base.

AbT.12.37.40 - Fig. 8.125

Dimensions: wall th.: 0.5 cm; base diam.: 5 cm; base th.: 0.6 cm.

Clay: outer, inner and fabric colour: 5YR 5/6 (yellowish red); sand inclusions; medium firing temperature.

Description: conical bowl base.

AbT.12.37.41 - Fig. 8.126

Dimensions: rim diam.: 12.6 cm; rim th.: 0.4 cm; wall th.: 0.4 cm.

Clay: outer, inner and fabric colour: 2.5Y 6/3 (light yellowish brown); sand inclusions; medium-high firing temperature.

Description: plain rim jar.

AbT.12.37.42 - Fig. 8.126

Dimensions: rim th.: 4 cm; wall th.: 2.4 cm.

Clay: outer, inner and fabric colour: 2.5Y 7/4 (pale yellow); sand and vegetal inclusions; medium-high firing temperature.

Description: thick oval rim vat/jar.

AbT.12.37.43 - Fig. 8.126

Dimensions: spout diam.: 1.4 cm; wall th.: 0.5 cm.

Clay: outer, inner and fabric colour: 2.5YR 6/8 (light red); sand inclusions; medium-low firing temperature.

Description: spout.

AbT.12.37.44 - Fig. 8.126

Dimensions: wall th.: 2.1 cm; base diam.: 48 cm; base th.: 1.6 cm.

Clay: outer and inner colour: 5YR 5/6 (yellowish red); fabric colour: 5YR 2.5/1 (black); sand inclusions; medium-high firing temperature.

Description: ring base.

AbT.12.37.45 - Fig. 8.126

Dimensions: wall th.: 2 cm.

Clay: outer, inner and fabric colour: 5Y 7/3 (pale yellow); sand and vegetal inclusions; high firing temperature.

Description: handle.

AbT.12.37.46 - Fig. 8.125

Dimensions: rim diam.: 9 cm; rim th.: 0.4 cm, wall th.: 0.6 cm.

Clay: outer, inner and fabric colour: 2.5YR 4/6 (red); sand inclusions; medium-high firing temperature.

Description: drinking vessel rim.

AbT.12.37.58 - Fig. 8.125

Dimensions: wall th.: 0.8 cm; base diam.: 4 cm; base th.: 1.8 cm.

Clay: outer, inner and fabric colour: 5YR 6/6 (reddish yellow); sand inclusions; medium-high firing temperature.

Description: beaker base.

AbT.12.37.59 - Fig. 8.125

Dimensions: rim diam.: 12.6 cm; rim th.: 0.5 cm; wall th.: 0.9 cm; base diam.: 4 cm; base th.: 1.2 cm; h.: 7.5 cm.

Clay: outer, inner and fabric colour: 2.5Y 7/3 (pale yellow); sand inclusions; medium-high firing temperature.

Description: conical bowl.

AbT.12.37.60 - Fig. 8.126

Dimensions: rim diam.: 13 cm; rim th.: 0.6 cm; wall th.: 0.7 cm.

Clay: outer and inner colour: 2.5Y 8/3 (pale brown); fabric colour: 7.5YR 6/4 (light brown); sand inclusions; medium-high firing temperature.

Description: plain rim jar.

AbT.12.37.61 - Fig. 8.125

Dimensions: rim th.: 0.7 cm; wall th.: 0.9 cm; base diam.: 5 cm.

Clay: outer, inner and fabric colour: 5YR 5/6 (yellowish red); sand inclusions; medium-high firing temperature.

Description: conical bowl base.

AbT.12.37.62 - Fig. 8.125

Dimensions: wall th.: 0.7 cm; base diam.: 5 cm; base th.: 0.8.

Clay: outer, inner and fabric colour: 5YR 5/6 (yellowish red); sand inclusions; medium-high firing temperature.

Description: conical bowl base.

Catalogue of US 38 Finds

Objects

AbT.12.15 - Fig. 8.116

Description: chert blade.

Dimensions: 1.6x4.5x0.2 cm.

AbT.12.19 - Fig. 8.116

Description: basalt grindstone.

Dimensions: 21x11 cm.

AbT.12.25 - Fig. 8.116

Description: stone pestle. Lower face with bitumen traces.

Dimensions: 8x11.5x5.5 cm.

AbT.12.28 - Fig. 8.116

Description: bone spatula.

Dimensions: 2.9x6.5x0.4 cm.

*Pottery***AbT.12.38.1 - Fig. 8.127**

Dimensions: wall th.: 0.8 cm; base diam.: 32.8 cm; base th.: 1.4 cm.

Clay: outer colour: 2.5Y 8/4 (pale yellow); inner colour: 10.5YR 7/4 (pink); fabric colour: 5YR 4/3 (reddish brown); sand inclusions; medium-high firing temperature.

Description: triangular rim bowl.

AbT.12.38.2 - Fig. 8.127

Dimensions: rim diam.: 15.4 cm; rim th.: 0.7 cm; wall th.: 0.6 cm.

Clay: outer, inner and fabric colour: 10YR 5/4 (yellowish brown); sand inclusions; medium-high firing temperature.

Description: convex base, with a hole at the beginning of the wall.

AbT.12.38.3 - Fig. 8.127

Dimensions: rim diam.: 12.2 cm; rim th.: 0.8 cm; wall th.: 0.7 cm; base diam.: 4.6 cm; base th.: 0.7 cm; h.: 3.5 cm.

Clay: outer and inner colour: 10YR 8/4 (very pale brown); fabric colour: 7.5YR 6/4 (light brown); sand inclusions; medium-high firing temperature.

Description: conical bowl attached to a stand.

AbT.12.38.4 - Fig. 8.127

Dimensions: wall th.: 0.7 cm; base diam.: 4.5 cm; base th.: 1.2 cm.

Clay: outer, inner and fabric colour: 10YR 7/6 (yellow); sand inclusions; medium-high firing temperature.

Description: beaker base.

AbT.12.38.5 - Fig. 8.127

Dimensions: wall th.: 0.9 cm; base diam.: 19 cm; base th.: 0.8 cm.

Clay: outer and inner colour: 2.5YR 6/6 (light red); fabric colour: 2.5YR 4/2 (weak red); sand inclusions; medium firing temperature.

Description: ring base.

AbT.12.38.6 - Fig. 8.127

Dimensions: wall th.: 1 cm; base diam.: 5 cm; base th.: 1 cm.

Clay: outer and inner colour: 2.5YR 5/6 (red); fabric colour: 2.5YR 4/2 (weak red); sand inclusions; medium-high firing temperature.

Description: beaker base.

AbT.12.38.7 - Fig. 8.127

Dimensions: wall th.: 0.9 cm; base diam.: 7 cm; base th.: 1.4 cm.

Clay: outer and inner colour: 10YR 8/6 (yellow); fabric colour: 5YR 4/4 (reddish brown); sand inclusions; medium-high firing temperature.

Description: cylinder.

AbT.12.38.8 - Fig. 8.127

Dimensions: wall th.: 0.9 cm; base diam.: 14.6 cm; base th.: 1 cm.

Clay: outer and inner colour: 10YR 7/4 (yellow); fabric colour: 5YR 5/6 (yellowish red); sand inclusions; medium-high firing temperature.

Description: flat base.

AbT.12.38.9 - Fig. 8.127

Dimensions: rim diam.: 19 cm; rim th.: 0.4 cm; rim wall th.: 0.5 cm.

Clay: outer, inner and fabric colour: 10YR 7/6 (yellow); sand inclusions; medium-high firing temperature.

Description: drinking vessel rim.

AbT.12.38.10 - Fig. 8.127

Dimensions: rim diam.: 15 cm; rim th.: 0.4 cm; wall th.: 0.36 cm.

Clay: outer, inner and fabric colour: 2.5YR 4/6 (red); sand inclusions; medium-high firing temperature.

Description: drinking vessel rim.

AbT.12.38.11 - Fig. 8.127

Dimensions: rim diam.: 28.2 cm; rim th.: 1.3 cm; wall th.: 1.2 cm.

Clay: outer, inner and fabric colour: 10YR 4/6 (red); sand inclusions; medium firing temperature.

Description: triangular rim bowl.

AbT.12.38.12 - Fig. 8.127

Dimensions: rim diam.: 15.2 cm; rim th.: 0.4 cm; wall th.: 0.4 cm.

Clay: outer, inner and fabric colour: 2.5YR 5/6 (red); sand inclusions; medium firing temperature.

Description: drinking vessel rim.

AbT.12.38.13 - Fig. 8.127

Dimensions: rim diam.: 13.8 cm; rim th.: 0.5 cm; wall th.: 0.6 cm.

Clay: outer, inner and fabric colour: 2.5YR 5/6 (red); sand inclusions; medium-high firing temperature.

Description: drinking vessel rim.

AbT.12.38.14 - Fig. 8.127

Dimensions: rim diam.: 16 cm; rim th.: 0.4 cm; wall th.: 0.5 cm.

Clay: outer, inner and fabric colour: 2.5YR 5/6 (red); sand inclusions; medium-high firing temperature.

Description: drinking vessel rim.

AbT.12.38.15 - Fig. 8.127

Dimensions: wall th.: 0.8 cm; base diam.: 5 cm; base th.: 1.3 cm.

Clay: outer, inner and fabric colour: not registered; sand inclusions; medium-high firing temperature.

Description: conical bowl base.

AbT.12.38.16 - Fig. 8.127

Dimensions: rim diam.: 15.8 cm; rim th.: 0.3 cm; wall th.: 0.4 cm.

Clay: outer, inner and fabric colour: 10YR 8/4 (very pale brown); sand inclusions; medium-high firing temperature.

Description: drinking vessel rim.

AbT.12.38.17 - Fig. 8.127

Dimensions: rim diam.: 14 cm; rim th.: 0.4 cm; wall th.: 0.7 cm.

Clay: outer, inner and fabric colour: not registered; sand inclusions; medium firing temperature.

Description: drinking vessel rim.

AbT.12.38.18 - Fig. 8.127

Dimensions: rim diam.: 18.4 cm; rim th.: 0.4 cm; wall th.: 0.5 cm.

Clay: outer, inner and fabric colour: 10YR 6/3 (pale brown); sand inclusions; medium-high firing temperature.

Description: drinking vessel rim.

AbT.12.38.19 - Fig. 8.127

Dimensions: wall th.: 0.8 cm; base diam.: 4.5 cm; base th.: 1 cm.

Clay: outer, inner and fabric colour: 5Y 6/6 (olive yellow); sand inclusions; medium-high firing temperature.

Description: conical bowl base.

AbT.12.38.20 - Fig. 8.127

Dimensions: wall th.: 0.6 cm; base diam.: 5.5 cm; base th.: 1.2 cm.

Clay: outer, inner and fabric colour: 5YR 5/6 (yellowish red); sand inclusions; medium-high firing temperature.

Description: conical bowl base.

AbT.12.38.21 - Fig. 8.127

Dimensions: wall th.: 0.6 cm; base diam.: 4.1 cm; base th.: 0.8 cm.

Clay: outer and inner colour: 5YR 8/4 (pink); fabric colour: 5YR 4/6 (yellowish red); sand inclusions; medium-high firing temperature.
Description: conical bowl base.

Catalogue of US 42 Finds

Objects

AbT.12.54 - Fig. 8.117

Description: white stone pebble.
Dimensions: 4x3x2 cm.

AbT.12.89 - Fig. 8.117

Description: lapis-lazuli bead.
Dimensions: 1x0.5 cm.

AbT.12.91 - Fig. 8.117

Description: lapis-lazuli bead.
Dimensions: 0.45x0.524 cm.

Pottery

AbT.12.42.1 - Fig. 8.128

Dimensions: rim diam.: 8.8 cm; rim th.: 0.5 cm; wall th.: 0.7 cm; base diam.: 3.5 cm; base th.: 0.8 cm; h.: 8.1 cm.
Clay: outer colour, inner, fabric colour: 5YR 6/3 (light reddish brown); sand inclusions; medium firing temperature.
Description: beaker.

AbT.12.42.2 - Fig. 8.128

Dimensions: rim diam.: 12 cm; rim th.: 0.3 cm; wall th.: 0.5 cm; base diam.: 4.5 cm; base th.: 1.1 cm; h.: 12 cm.
Clay: outer, inner and fabric colour: 10YR 8/4 (very pale brown); sand inclusions; medium-high temperature.
Description: beaker.

AbT.12.42.3 - Fig. 8.128

Dimensions: rim diam.: 20.4 cm; rim th.: 0.5 cm; wall th.: 0.8 cm; base diam.: 7.5 cm; base th.: 1 cm; h.: 8.5 cm.
Clay: outer, inner and fabric colour: 10YR 8/3 (very pale brown); sand inclusions; medium firing temperature.
Description: conical bowl.

AbT.12.42.4 - Fig. 8.130

Dimensions: wall th.: 0.6 cm; base diam.: 13 cm; base th.: 3 cm.
Clay: outer, inner and fabric colour: 7.5YR 8/4 (pink); sand inclusions; medium firing temperature.
Description: ring base.

AbT.12.42.5 - Fig. 8.128

Dimensions: rim diam.: 15 cm; rim th.: 0.6 cm; wall th.: 0.7 cm; base diam.: 6.1 cm; base th.: 0.9 cm; h.: 6.5 cm.
Clay: outer, inner and fabric colour: 2.5YR 6/6 (light red); sand inclusions; medium firing temperature.
Description: conical bowl.

AbT.12.42.6 - Fig. 8.128

Dimensions: rim diam.: 14 cm; rim th.: 0.4 cm; wall th.: 0.7 cm.
Clay: outer, inner and fabric colour: 10YR 8/4 (very pale brown); sand inclusions; medium firing temperature.
Description: drinking vessel rim.

AbT.12.42.7 - Fig. 8.128

Dimensions: wall th.: 0.6 cm; base diam.: 4.5 cm; base th.: 0.7 cm.
Clay: outer, inner and fabric colour: 5YR 7/6 (reddish yellow); sand inclusions; medium firing temperature.
Description: beaker base.

AbT.12.42.8 - Fig. 8.128

Dimensions: wall th.: 0.8 cm; base diam.: 5 cm; base th.: 1.1 cm.
Clay: outer, inner and fabric colour: 2.5Y 6/3 (light yellowish brown); sand inclusions; medium firing temperature.
Description: beaker base.

AbT.12.42.9 - Fig. 8.128

Dimensions: rim diam.: 14 cm; rim th.: 0.7 cm; wall th.: 0.8 cm.
Clay: outer, inner and fabric colour: 10YR 8/4 (very pale brown); sand inclusions; medium-high firing temperature.
Description: drinking vessel rim.

AbT.12.42.10 - Fig. 8.128

Dimensions: wall th.: 0.4 cm; base diam.: 4.5 cm; base th.: 1.3 cm.
Clay: outer, inner and fabric colour: 10YR 8/3 (very pale brown); sand inclusions; medium firing temperature.
Description: beaker base.

AbT.12.42.11 - Fig. 8.130

Dimensions: rim diam.: 10 cm; rim th.: 0.5 cm; wall th.: 0.7 cm.
Clay: outer, inner and fabric colour: 5Y 7/1 (light grey); sand inclusions; medium-high firing temperature.
Description: plain rim jar.

AbT.12.42.12 - Fig. 8.130

Dimensions: wall th.: 1.1 cm; base diam.: 14 cm; base th.: 2 cm.
Clay: outer, inner and fabric colour: 5YR 7/3 (pink); sand inclusions; medium firing temperature.
Description: ring base.

AbT.12.42.13 - Fig. 8.129

Dimensions: rim diam.: 12 cm; wall th.: 1.2 cm; base diam.: 7 cm; base th.: 0.6 cm.
Clay: outer, inner and fabric colour: 5YR 6/4 (light reddish brown); sand inclusions; medium firing temperature.
Description: cylinder ring base.

AbT.12.42.14 - Fig. 8.128

Dimensions: rim diam.: 12 cm; rim th.: 0.6 cm; wall th.: 0.7 cm.
Clay: outer, inner and fabric colour: 10YR 8/4 (very pale brown); sand inclusions; medium firing temperature.
Description: rim of a beaker with bitumen incrustation (also on the fracture, probably due to post depositional fluidification of bitumen).

AbT.12.42.15 - Fig. 8.128

Dimensions: wall th.: 0.8 cm; base diam.: 4.3 cm; base th.: 0.7 cm.
Clay: outer, inner and fabric colour: 5YR 6/4 (light reddish brown); sand inclusions; medium firing temperature.
Description: drinking vessel base.

AbT.12.42.16 - Fig. 8.129

Dimensions: rim diam.: 27 cm; rim th.: 1.2 cm; wall th.: 1.7 cm; base diam.: 28 cm; base th.: 2 cm; h.: 8.5 cm.
Clay: outer, inner and fabric colour: not registered; sand and vegetal inclusions; medium firing temperature.
Description: tray.

AbT.12.42.17 - Fig. 8.128

Dimensions: wall th.: 0.5 cm; base diam.: 4.6 cm; base th.: 0.6 cm.
Clay: outer, inner and fabric colour: 7.5YR 8/6 (reddish yellow); sand inclusions; medium-high firing temperature.
Description: beaker base.

AbT.12.42.18 - Fig. 8.130

Dimensions: wall th.: 0.7 cm; base diam.: 10 cm; base th.: 0.5 cm.
Clay: outer, inner and fabric colour: 7.5YR 6/4 (light brown); sand and

vegetal inclusions; medium firing temperature.

Description: convex base.

AbT.12.42.19 - Fig. 8.130

Dimensions: wall th.: 0.8 cm; base diam.: n.d.; base th.: 2.2 cm.

Clay: outer, inner, fabric colour: 10YR 7/4 (very pale brown); sand and vegetal inclusions; medium firing temperature. Description: ring base.

AbT.12.42.20 - Fig. 8.129

Dimensions: rim diam.: 12 cm; rim th.: 1.2 cm; wall th.: 0.9 cm; base diam.: 6.4 cm; base th.: 1 cm; h.: 3 cm.

Clay: outer and inner colour: 10YR 8/4 (very pale brown); fabric colour: 5YR 6/6 (reddish yellow); sand inclusions; medium firing temperature. Description: bowl attached to a stem.

AbT.12.42.21 - Fig. 8.130

Dimensions: wall th.: 2.2 cm; base diam.: 27 cm; base th.: 2.2 cm.

Clay: outer, inner and fabric colour: 7.5YR 6/6 (reddish yellow); sand inclusions; medium firing temperature. Description: ring base.

AbT.12.42.22 - Fig. 8.128

Dimensions: wall th.: 0.7 cm; base diam.: 4.5 cm; base th.: 1.4 cm.

Clay: outer, inner and fabric colour: 7.5YR 5/8 (strong brown); sand inclusions; medium firing temperature. Description: conical bowl base.

AbT.12.42.23 - Fig. 8.128

Dimensions: rim diam.: 13 cm; rim th.: 0.5 cm; wall th.: 0.5 cm.

Clay: outer, inner and fabric colour: 7.5YR 7/4 (pink); sand inclusions; medium firing temperature. Description: drinking vessel rim.

AbT.12.42.24 - Fig. 8.130

Dimensions: base th.: 4.5 cm.

Clay: outer, inner and fabric colour: 10YR 8/4 (very pale brown); sand and vegetal inclusions; medium-high firing temperature. Description: big ring base.

AbT.12.42.25 - Fig. 8.128

Dimensions: wall th.: 0.5 cm; base diam.: 4.3 cm; base th.: 1 cm.

Clay: outer, inner and fabric colour: 7.5YR 8/4 (pink); sand inclusions; medium-high firing temperature. Description: beaker base.

AbT.12.42.26 - Fig. 8.128

Dimensions: rim diam.: 9 cm; rim th.: 0.4 cm; wall th.: 0.5 cm.

Clay: outer, inner and fabric colour: 7.5YR 8/4 (pink); sand inclusions; medium firing temperature. Description: drinking vessel rim.

AbT.12.42.27 - Fig. 8.128

Dimensions: rim diam.: 14 cm; rim th.: 0.6 cm; wall th.: 0.7 cm.

Clay: outer, inner and fabric colour: 5YR 7/3 (pink); sand inclusions; medium firing temperature. Description: drinking vessel rim.

AbT.12.42.28 - Fig. 8.128

Dimensions: wall th.: 0.6 cm; base diam.: 3.5 cm; base th.: 0.5 cm.

Clay: outer, inner and fabric colour: 5YR 6/6 (reddish yellow); sand inclusions; medium firing temperature. Description: drinking vessel base.

AbT.12.42.29 - Fig. 8.128

Dimensions: wall th.: 1.1 cm; base diam.: 4.4 cm; base th.: 1.3 cm.

Clay: outer, inner and fabric colour: 5YR 6/6 (reddish yellow); sand inclusions; medium firing temperature. Description: drinking vessel base.

AbT.12.42.30 - Fig. 8.130

Dimensions: wall th.: 0.5 cm; base diam.: 10 cm; base th.: 0.7 cm.

Clay: outer, inner and fabric colour: 2.5YR 7/3 (light reddish brown); sand inclusions; medium firing temperature. Description: convex base jar.

AbT.12.42.31 - Fig. 8.128

Dimensions: rim diam.: 11 cm; rim th.: 0.5; wall th.: 0.55 cm.

Clay: outer, inner and fabric colour: 5YR 7/3 (pink); sand inclusions; medium firing temperature. Description: drinking vessel rim.

AbT.12.42.32 - Fig. 8.130

Dimensions: rim diam.: 9 cm; rim th.: 0.4 cm; wall th.: 0.6 cm.

Clay: outer, inner and fabric colour: 10YR 7/3 (very pale brown); sand inclusions; medium firing temperature. Description: plain rim jar.

AbT.12.42.33 - Fig. 8.130

Dimensions: wall th.: 0.6 cm; base diam.: 10 cm; base th.: 0.6 cm.

Clay: outer, inner and fabric colour: 7.5YR 7/6 (reddish yellow); sand inclusions; medium firing temperature. Description: ring base.

AbT.12.42.34 - Fig. 8.128

Dimensions: wall th.: 0.9 cm; base diam.: 4 cm; base th.: 1.3 cm.

Clay: outer, inner and fabric colour: 5YR 7/6 (reddish yellow); sand inclusions; medium firing temperature. Description: beaker base.

AbT.12.42.35 - Fig. 8.128

Dimensions: wall th.: 0.7 cm; base diam.: 4 cm; base th.: 0.8 cm.

Clay: outer and inner colour: 10YR 7/4 (very pale brown); fabric colour: 5YR 6/6 (reddish yellow); sand inclusions; medium firing temperature. Description: beaker base.

AbT.12.42.36 - Fig. 8.128

Dimensions: wall th.: 0.6 cm; base diam.: 4.8 cm; base th.: 1.3 cm.

Clay: outer, inner and fabric colour: 10YR 7/6 (yellow); sand inclusions; medium firing temperature. Description: conical bowl base.

AbT.12.42.37 - Fig. 8.128

Dimensions: wall th.: 0.7 cm; base diam.: 4.6 cm; base th.: 0.8 cm.

Clay: outer, inner and fabric colour: 5YR 6/6 (reddish yellow); sand inclusions; medium firing temperature. Description: beaker base.

AbT.12.42.38 - Fig. 8.128

Dimensions: rim diam.: 11.2 cm; rim th.: 0.4 cm; wall th.: 0.8 cm; base diam.: 4.6 cm; base th.: 1.6 cm; h.: 12.2 cm.

Clay: outer and fabric colour: 5YR 4/6 (yellowish red); inner colour: 2.5Y 6/4 (light yellowish brown); sand inclusions; medium firing temperature. Description: beaker.

AbT.12.42.39 - Fig. 8.128

Dimensions: rim diam.: 11.2 cm; rim th.: 0.5 cm; wall th.: 0.4 cm.

Clay: outer, inner and fabric colour: 10YR 6/6 (brownish yellow); sand inclusions; medium firing temperature. Description: drinking vessel rim.

AbT.12.42.40 - Fig. 8.128

Dimensions: rim diam.: 11.5 cm; rim th.: 0.5 cm; wall th.: 0.4 cm.
Clay: outer, inner and fabric colour: 10YR 6/6 (brownish yellow); sand inclusions; medium firing temperature.
Description: drinking vessel rim.

AbT.12.42.41 - Fig. 8.128

Dimensions: rim diam.: 10 cm; rim th.: 0.4 cm; wall th.: 0.4 cm.
Clay: outer, inner and fabric colour: 5Y 7/3 (pale yellow); sand inclusions; medium-high firing temperature.
Description: drinking vessel rim.

AbT.12.42.42 - Fig. 8.133

Dimensions: rim diam.: 34.6 cm; rim th.: 2 cm; wall th.: 0.9 cm.
Clay: outer, inner and fabric colour: 10YR 6/4 (light yellowish brown); sand inclusions; medium firing temperature.
Description: triangular rim bowl.

AbT.12.42.43 - Fig. 8.128

Dimensions: wall th.: 1 cm; base diam.: 5 cm; base th.: 1.1 cm.
Clay: outer, inner and fabric colour: 5YR 7/6 (reddish yellow); sand inclusions; medium firing temperature.
Description: drinking vessel base.

AbT.12.42.44 - Fig. 8.128

Dimensions: wall th.: 1.1 cm; base diam.: 5 cm; base th.: 1.1 cm.
Clay: outer, inner and fabric colour: 2.5Y 8/4 (pale brown); sand inclusions; medium firing temperature.
Description: conical bowl base.

AbT.12.42.45 - Fig. 8.128

Dimensions: rim diam.: 12 cm; rim th.: 0.6 cm; wall th.: 0.6 cm.
Clay: outer, inner and fabric colour: 2.5Y 6/3 (light yellowish brown); sand inclusions; medium firing temperature.
Description: drinking vessel rim with bitumen inside.

AbT.12.42.46 - Fig. 8.130

Dimensions: rim diam.: n.d.; rim th.: 3 cm; wall th.: 2.6 cm.
Clay: outer, inner and fabric colour: 2.5Y 6/3 (light yellowish brown); sand and vegetal inclusions; medium firing temperature.
Description: rounded rim big jar/vat with a small ridge on the wall.

AbT.12.42.47 - Fig. 8.128

Dimensions: wall th.: 1.4 cm; base diam.: 4.5 cm; base th.: 1.1 cm.
Clay: outer and inner colour: 10YR 7/4 (very pale brown); fabric colour: 2.5YR 6/8 (light red); sand inclusions; medium firing temperature.
Description: drinking vessel base.

AbT.12.42.48 - Fig. 8.128

Dimensions: wall th.: 1.1 cm; base diam.: 10.6 cm; base th.: 1.1 cm.
Clay: outer, inner and fabric colour: 2.5YR 6/6 (light red); sand and vegetal inclusions; medium firing temperature.
Description: flat base.

AbT.12.42.49 - Fig. 8.128

Dimensions: rim diam.: 14.3 cm; rim th.: 0.5 cm; wall th.: 0.4 cm.
Clay: outer, inner and fabric colour: 2.5YR 7/4 (light reddish brown); sand inclusions; medium firing temperature.
Description: drinking vessel rim.

AbT.12.42.50 - Fig. 8.128

Dimensions: rim diam.: 13 cm; rim th.: 0.5 cm; wall th.: 0.3 cm.
Clay: outer, inner and fabric colour: 5YR 8/4 (pink); sand inclusions; medium firing temperature.
Description: drinking vessel rim.

AbT.12.42.51 - Fig. 8.128

Dimensions: rim diam.: 14.8 cm; rim th.: 0.5 cm; wall th.: 0.5 cm.
Clay: outer, inner and fabric colour: 5YR 8/4 (pink) sand inclusions; medium-high firing temperature.
Description: drinking vessel rim.

AbT.12.42.52 - Fig. 8.128

Dimensions: rim diam.: 11 cm; rim th.: 0.3 cm; wall th.: 0.5 cm.
Clay: outer, inner and fabric colour: 10YR 7/4 (very pale brown) sand inclusions; medium-high firing temperature.
Description: drinking vessel rim.

AbT.12.42.53 - Fig. 8.128

Dimensions: wall th.: 0.6 cm; base diam.: 5.2 cm; base th.: 0.7 cm.
Clay: outer and inner colour: 10YR 6/3 (very pale brown); fabric colour: 5YR 5/6 (yellowish red); sand inclusions; medium firing temperature.
Description: beaker base.

AbT.12.42.54 - Fig. 8.128

Dimensions: wall th.: 0.6 cm; base diam.: 4.4 cm; base th.: 1.6 cm.
Clay: outer, inner and fabric colour: 5YR 6/6 (reddish yellow) sand inclusions; medium firing temperature.
Description: conical bowl base.

AbT.12.42.55 - Fig. 8.130

Dimensions: spout diam.: 2.2 cm; wall th.: 0.9 cm.
Clay: outer, inner and fabric colour: 10YR 6/3 (pale brown); sand inclusions; medium-high firing temperature.
Description: spout.

AbT.12.42.56 - Fig. 8.130

Dimensions: rim diam.: 10.9 cm; rim th.: 0.5 cm; wall th.: 0.8 cm.
Clay: outer, inner and fabric colour: 10YR 7/3 (very pale brown); sand inclusions; medium-high firing temperature.
Description: plain rim jar.

AbT.12.42.57 - Fig. 8.129

Dimensions: wall th.: 1.8 cm; base diam.: n.d.; base th.: 2 cm.
Clay: outer, inner and fabric colour: 10YR 7/6 (yellow); sand and vegetal inclusions; medium firing temperature.
Description: flat base of a tray.

AbT.12.42.58 - Fig. 8.130

Dimensions: rim diam.: 18 cm; rim th.: 1.1 cm; wall th.: 0.8 cm.
Clay: outer, inner and fabric colour: 10YR 7/4 (very pale brown); sand inclusions; medium firing temperature.
Description: triangular rim jar.

AbT.12.42.59+60 - Fig. 8.129

Dimensions: rim diam.: 40 cm; rim th.: 2 cm; wall th.: 0.8 cm; base diam.: 20 cm; base th.: 1 cm; h.: 17 cm.
Clay: outer, inner and fabric colour: 2.5 YR 7/6 (yellow); sand inclusions; medium-high firing temperature.
Description: triangular rim bowl.

AbT.12.42.61 - Fig. 8.130

Dimensions: wall th.: 1 cm; base diam.: 60 cm; base th.: 2 cm.
Clay: outer, inner and fabric colour: 2.5Y 7/2 (light grey); sand inclusions; medium-high firing temperature.
Description: ring base.

AbT.12.42.62 - Fig. 8.129

Dimensions: wall th.: 1.8 cm; base diam.: n.d.; base th.: 1.2 cm.

Clay: outer, inner and fabric colour: 5YR 6/4 (light reddish brown); sand and vegetal inclusions; medium-high firing temperature.

Description: flat base of a tray.

AbT.12.42.63 - Fig. 8.130

Dimensions: rim diam.: 4 cm; rim th.: 0.6 cm; wall th.: 0.8 cm.

Clay: outer, inner and fabric colour: 10YR 8/3 (very pale brown); sand inclusions; medium-high firing temperature.

Description: miniaturistic plain rim jar.

AbT.12.42.64 - Fig. 8.130

Dimensions: rim diam.: 12 cm; rim th.: 0.3 cm; wall th.: 0.3 cm.

Clay: outer, inner and fabric colour: 2.5Y 6/2 (light brownish grey); sand inclusions; medium-high firing temperature.

Description: plain rim jar.

AbT.12.42.65 - Fig. 8.128

Dimensions: rim diam.: 10.6 cm; rim th.: 0.4 cm; wall th.: 0.5 cm.

Clay: outer and inner colour: 10YR 7/4 (very pale brown); fabric colour: 2.5YR 7/8 (light red); sand inclusions; medium-high firing temperature.

Description: drinking vessel rim.

AbT.12.42.66 - Fig. 8.130

Dimensions: rim diam.: 10 cm; rim th.: 0.9 cm; wall th.: 0.6 cm.

Clay: outer and inner colour: 2.5Y 7/4 (pale yellow); fabric colour: 5YR 6/6 (reddish yellow); sand inclusions; medium-high firing temperature.

Description: hole mouth jar.

AbT.12.42.67 - Fig. 8.128

Dimensions: rim diam.: 14.2 cm; rim th.: 0.5 cm; wall th.: 0.8 cm.

Clay: outer and inner colour: 10YR 8/3 (very pale brown); fabric colour: 2.5YR 5/6 (red); sand inclusions; medium-high firing temperature.

Description: drinking vessel rim.

AbT.12.42.68 - Fig. 8.130

Dimensions: rim diam.: 14 cm; rim th.: 0.4 cm; wall th.: 0.5 cm.

Clay: outer, inner and fabric colour: 2.5YR 7/6 (light red); sand inclusions; medium firing temperature.

Description: band rim jar.

AbT.12.42.69 - Fig. 8.130

Dimensions: wall th.: 0.8 cm; base diam.: 16 cm; base th.: 0.7 cm.

Clay: outer and inner colour: 10YR 8/3 (very pale brown); fabric colour: 5YR 6/4 (light reddish brown); sand inclusions; medium firing temperature.

Description: slightly convex base.

AbT.12.42.70 - Fig. 8.130

Dimensions: rim diam.: 12.8 cm; rim th.: 0.4 cm; wall th.: 0.6 cm.

Clay: outer, inner and fabric colour: 10YR 8/3 (very pale brown); sand inclusions; medium-high firing temperature.

Description: plain rim jar.

AbT.12.42.71 - Fig. 8.130

Dimensions: rim diam.: 9.8 cm; rim th.: 0.5 cm; wall th.: 0.8 cm.

Clay: outer, inner and fabric colour: 10YR 8/4 (yellow); sand inclusions; medium-high firing temperature.

Description: plain rim jar.

AbT.12.42.72 - Fig. 8.130

Dimensions: rim diam.: 9.4 cm; rim th.: 0.5 cm; wall th.: 0.6 cm.

Clay: outer, inner and fabric colour: 10YR 8/3 (very pale brown); sand inclusions; medium-high firing temperature.

Description: plain rim jar.

AbT.12.42.73 - Fig. 8.128

Dimensions: rim diam.: 19.4 cm; rim th.: 0.4 cm; wall th.: 0.6 cm.

Clay: outer, inner and fabric colour: 10YR 7/4 (very pale brown); sand inclusions; medium-high firing temperature.

Description: drinking vessel rim.

AbT.12.42.74 - Fig. 8.128

Dimensions: rim diam.: 16.6 cm; rim th.: 0.4 cm; wall th.: 0.9 cm.

Clay: outer, inner and fabric colour: 2.5YR 5/6 (red); sand inclusions; medium firing temperature.

Description: drinking vessel rim.

AbT.12.42.75 - Fig. 8.128

Dimensions: wall th.: 0.8 cm; base diam.: 3 cm; base th.: 1.7 cm.

Clay: outer, inner and fabric colour: 5YR 5/6 (yellowish red); sand inclusions; medium firing temperature.

Description: beaker base.

AbT.12.42.76 - Fig. 8.128

Dimensions: wall th.: 0.8 cm; base diam.: 5 cm; base th.: 0.9 cm.

Clay: outer, inner and fabric colour: 2.5YR 5/6 (red); sand inclusions; medium firing temperature.

Description: conical bowl base.

AbT.12.42.77 - Fig. 8.128

Dimensions: rim diam.: 18 cm; rim th.: 0.6 cm; wall th.: 0.8 cm.

Clay: outer, inner and fabric colour: 2.5Y 7/4 (pale yellow); sand inclusions; medium-high firing temperature.

Description: drinking vessel rim.

AbT.12.42.78 - Fig. 8.130

Dimensions: rim diam.: 13 cm; rim th.: 3.3 cm; wall th.: 0.9 cm.

Clay: outer, inner and fabric colour: 2.5Y 7/3 (pale yellow); sand inclusions; medium-high firing temperature.

Description: plain rim jar.

AbT.12.42.79 - Fig. 8.130

Dimensions: wall th.: 0.8 cm; base diam.: 15 cm; base th.: 0.9 cm.

Clay: outer, inner and fabric colour: 10YR 7/6 (yellow); sand inclusions; medium-high firing temperature.

Description: ring base with bitumen traces mixed with vegetal temper (also on the fracture, probably due to post-depositional fluidification of bitumen).

AbT.12.42.80 - Fig. 8.130

Dimensions: rim diam.: 14 cm; rim th.: 0.6 cm; wall th.: 0.6 cm.

Clay: outer, inner and fabric colour: 10YR 8/3 (very pale brown); sand inclusions; medium-high firing temperature.

Description: plain rim jar.

AbT.12.42.81 - Fig. 8.129

Dimensions: rim diam.: 16.8 cm; rim th. 1; wall th.: 0.9 cm.

Clay: outer, inner and fabric colour: 5YR 6/6 (reddish yellow); sand inclusions; medium firing temperature.

Description: triangular rim bowl.

AbT.12.42.82 - Fig. 8.130

Dimensions: wall th.: 0.9 cm; base diam.: 13 cm; base th.: 0.8 cm.

Clay: outer, inner and fabric colour: 2.5Y 7/4 (pale yellow); sand inclusions; medium-high firing temperature.
Description: ring base.

AbT.12.42.83 - Fig. 8.128

Dimensions: wall th.: 0.6 cm; base diam.: 4.1 cm; base th.: 1.6 cm.
Clay: outer, inner and fabric colour: 5YR 7/6 (reddish yellow); sand inclusions; medium firing temperature.
Description: beaker base.

AbT.12.42.84 - Fig. 8.128

Dimensions: wall th.: 0.4 cm; base diam.: 5 cm; base th.: 1.3 cm.
Clay: outer, inner and fabric colour: 10R 6/3 (pale red); sand inclusions; medium firing temperature.
Description: beaker base.

AbT.12.42.85 - Fig. 8.128

Dimensions: rim diam.: 11.7 cm; rim th.: 0.4 cm; wall th.: 0.6 cm; base diam.: 4.6 cm; base th.: 0.7 cm; h.: 8.6 cm.
Clay: outer, inner and fabric colour: 10R 5/4 (weak red); sand inclusions; medium firing temperature.
Description: conical bowl.

AbT.12.42.86 - Fig. 8.128

Dimensions: rim diam.: 12.4 cm; rim th.: 0.5 cm; wall th.: 0.7 cm; base diam.: 4.2 cm; base th.: 0.8 cm; h.: 6.5 cm.
Clay: outer, inner and fabric colour: 2.5Y 7/4 (pale yellow); sand inclusions; medium-high firing temperature.
Description: conical bowl.

AbT.12.42.87 - Fig. 8.130

Dimensions: rim diam.: 26.4 cm; rim th.: 1.3 cm; wall th.: 0.8 cm.
Clay: outer, inner and fabric colour: 2.5Y 6/4 (light yellowish brown); sand inclusions; medium-high firing temperature.
Description: out-turned rim jar.

AbT.12.42.88 - Fig. 8.128

Dimensions: wall th.: 0.6 cm; base diam.: 4 cm; base th.: 2 cm.
Clay: outer, inner and fabric colour: 5Y 7/3 (pale yellow); sand inclusions; medium-high firing temperature.
Description: beaker base.

AbT.12.42.89 - Fig. 8.128

Dimensions: wall th.: 0.7 cm; base diam.: 5.4 cm; base th.: 0.6 cm.

Clay: outer, inner and fabric colour: 2.5YR 5/6 (red); sand inclusions; medium firing temperature.
Description: beaker base.

AbT.12.42.90 - Fig. 8.130

Dimensions: wall th.: 0.4 cm; base diam.: 13 cm; base th.: 0.6 cm.
Clay: outer, inner and fabric colour: 2.5Y 7/4 (pale yellow); sand inclusions; medium-high firing temperature.
Description: ring base.

AbT.12.42.91 - Fig. 8.130

Dimensions: rim diam.: 15.2 cm; rim th.: 0.9 cm; wall th.: 0.6 cm.
Clay: outer, inner and fabric colour: 2.5Y 8/3 (pale yellow); sand inclusions; medium-high firing temperature.
Description: plain rim jar.

AbT.12.42.92 - Fig. 8.130

Dimensions: rim diam.: 12 cm; rim th.: 0.5 cm; wall th.: 0.5 cm.
Clay: outer, inner and fabric colour: 5YR 7/4 (pink); sand inclusions; medium-high firing temperature.
Description: band rim jar.

AbT.12.42.93 - Fig. 8.130

Dimensions: rim diam.: 18 cm; rim th.: 0.7 cm; wall th.: 0.9 cm.
Clay: outer, inner and fabric colour: 10YR 6/3 (pale brown); sand inclusions; medium-high firing temperature.
Description: double-ridged rim jar.

AbT.12.42.94 - Fig. 8.128

Dimensions: rim diam.: 15 cm; rim th.: 0.5 cm; wall th.: 0.7 cm; base diam.: 5.2 cm; base th.: 0.8 cm; h.: 6.8 cm.
Clay: outer, inner and fabric colour: 5YR 7/6 (reddish yellow); sand inclusions; medium firing temperature.
Description: conical bowl.

AbT.12.42.95 - Fig. 8.130

Dimensions: rim diam.: 18 cm; rim th.: 0.6 cm; wall th.: 0.6 cm.
Clay: outer, inner and fabric colour: 10YR 6/3 (pale brown); sand inclusions; medium firing temperature.
Description: plain rim jar.

AbT.12.42.96 - Fig. 8.129

Dimensions: rim diam.: 26 cm; rim th.: 1.3 cm; wall th.: 1.8 cm; base diam.: 27 cm; base th.: 2.2 cm; h.: 8.7 cm.
Clay: outer, inner and fabric colour: 2.5YR 6/3 (light reddish brown); sand

and vegetal inclusions; medium firing temperature.
Description: tray.

AbT.12.42.97 - Fig. 8.130

Dimensions: rim diam.: 12 cm; rim th.: 0.3 cm; wall th.: 0.7 cm.
Clay: outer, inner and fabric colour: 10YR 6/4 (light yellowish brown); sand inclusions; medium-high firing temperature.
Description: band rim jar.

AbT.12.42.98 - Fig. 8.128

Dimensions: wall th.: 1.1 cm; base diam.: 7 cm; base th.: 1.6 cm.
Clay: outer, inner and fabric colour: 2.5YR 5/4 (reddish brown); sand inclusions; medium-high firing temperature.
Description: drinking vessel base.

AbT.12.42.99 - Fig. 8.128

Dimensions: rim diam.: 10 cm; rim th.: 0.3 cm; wall th.: 0.5 cm.
Clay: outer, inner and fabric colour: 10YR 8/3 (very pale brown); sand inclusions; medium-high firing temperature.
Description: drinking vessel rim.

AbT.12.42.100 - Fig. 8.130

Dimensions: rim diam.: 24 cm; rim th.: 0.7 cm; wall th.: 0.5 cm.
Clay: outer, inner and fabric colour: 5YR 7/3 (pink); sand inclusions; medium-high firing temperature.
Description: plain rim jar with incised zigzag line on the neck.

AbT.12.42.101 - Fig. 8.128

Dimensions: rim diam.: 11.5 cm; rim th.: 0.4 cm; wall th.: 0.7 cm; base diam.: 6.8 cm; base th.: 0.4 cm; h.: 17 cm.
Clay: outer, inner and fabric colour: 2.5Y 7/3 (pale yellow); sand inclusions; medium-high firing temperature.
Description: beaker.

AbT.12.42.102 - Fig. 8.128

Dimensions: wall th.: 1 cm; base diam.: 5.2 cm; base th.: 0.4 cm.
Clay: outer, inner and fabric colour: 5YR 5/6 (yellowish red); sand inclusions; medium firing temperature.
Description: drinking vessel base.

AbT.12.42.103 - Fig. 8.129

Dimensions: rim diam.: 28 cm; rim th.: 1.5 cm; wall th.: 22 cm.

Clay: outer, inner and fabric colour: 5Y 8/2 (pale yellow); sand inclusions; medium-high firing temperature.
Description: plain rim of a tray or fragment of a huge ring base with bitumen traces.

AbT.12.42.104 - Fig. 8.128

Dimensions: wall th.: 0.7 cm; base diam.: 4 cm; base th.: 0.7 cm.
Clay: outer and inner colour: 2.5YR 7/8 (light red); fabric colour: 2.5YR 4/6 (red); sand inclusions; medium firing temperature.
Description: beaker base.

AbT.12.42.105 - Fig. 8.130

Dimensions: wall th.: 0.4 cm; base diam.: 11 cm; base th.: 0.4 cm.
Clay: outer, inner and fabric colour: 2.5Y 6/3 (light yellowish brown); sand inclusions; medium firing temperature.
Description: ring base.

AbT.12.42.106 - Fig. 8.128

Dimensions: rim diam.: 16.7 cm; rim th.: 0.4 cm; wall th.: 0.6 cm.
Clay: outer, inner and fabric colour: 2.5Y 8/6 (yellow); sand inclusions; medium-high firing temperature.
Description: drinking vessel rim.

AbT.12.42.107 - Fig. 8.130

Dimensions: rim diam.: 14.4 cm; rim th.: 0.3 cm; wall th.: 0.5 cm.
Clay: outer, inner and fabric colour: 5Y 7/2 (light grey); sand inclusions; medium-high firing temperature.
Description: plain rim jar.

AbT.12.42.108 - Fig. 8.130

Dimensions: wall th.: 0.7 cm; base diam.: 12 cm; base th.: 0.8 cm.
Clay: outer, inner and fabric colour: 2.5Y 7/4 (pale yellow); sand inclusions; medium-high firing temperature.
Description: ring base.

AbT.12.42.109 - Fig. 8.128

Dimensions: wall th.: 1 cm; base diam.: 5 cm; base th.: 1.2 cm.
Clay: outer, inner and fabric colour: 2.5YR 5/6 (red); sand inclusions; medium-high firing temperature.
Description: drinking vessel base.

AbT.12.42.110 - Fig. 8.130

Dimensions: rim diam.: 18.8 cm; rim th.: 0.6 cm; wall th.: 0.5 cm; h.: 44 cm.

Clay: outer colour: 10YR 6/3 (pale brown), inner and fabric colour: 7.5YR 5/4 (brown); sand inclusions; medium-high firing temperature.
Description: band rim jar.

AbT.12.42.111 - Fig. 8.130

Dimensions: rim diam.: 17 cm; rim th.: 1.4 cm; wall th.: 0.7 cm.
Clay: outer, inner and fabric colour: 10YR 8/3 (very pale brown); sand inclusions; medium firing temperature.
Description: triangular rim jar.

Catalogue of US 134 Finds

Objects

AbT.13.42 - Fig. 8.118

Description: chert blade.
Dimensions: 1.6x4.5x0.5 cm.

Pottery

AbT.13.134.1 - Fig. 8.131

Dimensions: rim diam.: 14.5 cm; rim th.: 0.6 cm; wall th.: 0.7 cm; base diam.: 5.8 cm; base th.: 1.2 cm; h.: 7.8 cm.
Clay: outer colour: 10YR 7/4 (very pale brown); inner colour: 10YR 8/3 (very pale brown); fabric colour: 10YR 6/4 (light yellowish brown); sand inclusions; medium firing temperature.
Description: conical bowl, found in association with 11 shells.

AbT.13.134.2 - Fig. 8.131

Dimensions: rim diam.: 14 cm; rim th.: 0.6 cm; wall th.: 0.7 cm; base diam.: 5 cm; base th.: 1.3 cm; h.: 7.8 cm.
Clay: outer colour: 2.5Y 8/3 (pale brown); inner colour: 7.5YR 7/4 (pink); fabric colour: 5YR 6/4 (light reddish brown); sand inclusions; medium-low firing temperature.
Description: conical bowl.

AbT.13.134.3 - Fig. 8.131

Dimensions: wall th.: 0.6 cm; base diam.: 4 cm; base th.: 1 cm.
Clay: outer and inner colour: 10YR 8/2 (very pale brown); fabric colour: 7.5YR 7/4 (pink); sand inclusions; medium firing temperature.
Description: beaker base.

AbT.13.134.4 - Fig. 8.131

Dimensions: wall th.: 0.7 cm; base diam.: 4.5 cm; base th.: 1 cm.

Clay: outer colour: 2.5Y 7/3 (pale brown); inner and fabric colour: 7.5YR 6/4 (light brown); sand inclusions; medium firing temperature.
Description: beaker base.

AbT.13.134.5 - Fig. 8.131

Dimensions: wall th.: 0.9 cm; base diam.: 6 cm; base th.: 0.9 cm.
Clay: outer colour: 5Y 8/2 (pale yellow); inner and fabric colour: 2.5Y 7/3 (pale brown); sand inclusions; medium firing temperature.
Description: beaker base.

AbT.13.134.6 - Fig. 8.131

Dimensions: wall th.: 0.8 cm; base diam.: 4.5 cm; base th.: 3.4 cm.
Clay: outer colour: 2.5Y 8/3 (pale brown); inner and fabric colour: 7.5YR 6/4 (light brown); sand inclusions; medium firing temperature.
Description: pointed base.

AbT.13.134.7 - Fig. 8.131

Dimensions: rim diam.: 34 cm; rim th.: 1 cm; wall th.: 1 cm.
Clay: outer and inner colour: 2.5Y 8/2 (pale brown); fabric colour: 7.5YR 6/4 (light brown); sand inclusions; medium firing temperature.
Description: shallow bowl rim.

AbT.13.134.8 - Fig. 8.131

Dimensions: rim diam.: 20 cm; rim th.: 1 cm; wall th.: 0.7 cm.
Clay: outer and inner colour: 10YR 8/2 (very pale brown); fabric colour: 7.5YR 5/6 (strong brown); sand inclusions; medium-low firing temperature.
Description: shallow bowl rim.

AbT.13.134.9 - Fig. 8.131

Dimensions: rim diam.: 24 cm; rim th.: 1.3 cm; wall th.: 0.7 cm.
Clay: outer and inner colour: 5Y 8/2 (pale yellow); fabric colour: 10YR 6/4 (light yellowish brown); sand inclusions; medium firing temperature.
Description: triangular rim bowl.

AbT.13.134.10 - Fig. 8.131

Dimensions: rim diam.: 25 cm; rim th.: 1.5 cm; wall th.: 1 cm.
Clay: outer and inner colour: 10YR 8/2 (very pale brown); fabric colour: 10YR 6/4 (light yellowish brown); sand inclusions; medium firing temperature.
Description: triangular rim bowl.

AbT.13.134.11 - Fig. 8.131

Dimensions: rim diam.: 28 cm; rim th.: 2 cm; wall th.: 1 cm.

Clay: outer and inner colour: 5Y 8/2 (pale yellow); fabric colour: 7.5YR 6/4 (light brown); sand inclusions; medium firing temperature.

Description: triangular rim bowl.

AbT.13.134.12 - Fig. 8.131

Dimensions: rim diam.: 13 cm; rim th.: 0.4 cm; wall th.: 0.8 cm.

Clay: outer colour (slip?): 10YR 8/2 (very pale brown); inner colour: 10YR 8/2 (very pale brown); fabric colour: 5YR 6/6 (reddish yellow); sand inclusions; medium-low firing temperature.

Description: plain rim jar.

AbT.13.134.13+14 - Fig. 8.131

Dimensions: rim diam.: 15.7 cm; rim th.: 0.6 cm; wall th.: 0.8 cm.

Clay: outer, inner and fabric colour: 2.5Y 8/3 (pale brown); sand inclusions; medium firing temperature.

Description: plain rim jar.

AbT.13.134.15 - Fig. 8.131

Dimensions: rim diam.: 15 cm; rim th.: 0.6 cm; wall th.: 0.6 cm.

Clay: outer and inner colour: 2.5Y 8/2 (pale brown); fabric colour: 10YR 6/4 (light yellowish brown); sand inclusions; medium firing temperature.

Description: plain rim of a jar with a small ridge on the wall.

AbT.13.134.16 - Fig. 8.131

Dimensions: wall th.: 1 cm.

Clay: outer colour: 2.5Y 8/2 (pale brown); inner colour: 10YR 8/2 (very pale brown); fabric colour: 7.5YR 6/4 (light brown); sand inclusions; medium-high firing temperature.

Description: fragment of a jar with a series of impressed decorations at the base of the neck.

AbT.13.134.17 - Fig. 8.131

Dimensions: wall th.: 0.7 cm; base diam.: 10 cm; base th.: 0.4 cm.

Clay: outer and inner colour: 2.5Y 8/3 (pale brown); fabric colour: 7.5YR 6/4 (light brown); sand inclusions; medium-high firing temperature.

Description: ring base.

Catalogue of US 143 Finds

*Pottery***AbT.13.143.1 - Fig. 8.132**

Dimensions: wall th.: 1.25 cm; base diam.: 23.5 cm; base th.: 0.9 cm; h.: 27.6 cm (max. preserved).

Clay: outer colour (self slip on the upper part): 2.5Y 8/2 (pale brown); inner and fabric colour: 7.5YR 7/3 (pink); sand inclusions; medium firing temperature.

Description: richly decorated jar with ring base and two ridges framing the shoulder section. The decoration on the upper part of the body consists of (from the neck to the base) one line of small incisions, an applied notched ridge, four incised wavy lines and a second applied notched ridge.

Catalogue of US 147 Finds

*Pottery***AbT.13.147.1 - Fig. 8.133**

Dimensions: rim diam.: 14 cm; rim th.: 0.6 cm; wall th.: 0.7 cm; base diam.: 5 cm; base th.: 0.9 cm; h.: 11.7 cm.

Clay: outer colour: 2.5Y 9/2 (very pale yellow); inner colour: 7.5YR 8/2 (pinkish white); fabric colour: 7.5YR 6/6 (reddish yellow); sand inclusions; medium-low firing temperature.

Description: beaker.

AbT.13.147.2 - Fig. 8.133

Dimensions: wall th.: 0.8 cm; base diam.: 4.5 cm; base th.: 1.2 cm.

Clay: outer and inner colour: 7.5YR 6/4 (light brown); fabric colour: 7.5YR 5/6 (strong brown); sand inclusions; medium-low firing temperature.

Description: conical bowl base.

AbT.13.147.3 - Fig. 8.133

Dimensions: rim diam.: 28 cm; rim th.: 0.8 cm; wall th.: 1.2 cm.

Clay: outer colour: 2.5Y 8/2 (pale brown); inner colour: 10YR 8/3 (very pale brown); fabric colour: 7.5YR 6/4 (light brown); sand inclusions; medium firing temperature.

Description: stem base (?).

AbT.13.147.4 - Fig. 8.133

Dimensions: rim diam.: 14 cm; rim th.: 0.6 cm; wall th.: 0.5 cm.

Clay: outer and inner colour: 10YR 8/3 (very pale brown); fabric colour: 7.5YR 5/6 (strong brown); sand inclusions; medium firing temperature.

Description: band rim jar.

AbT.13.147.5 - Fig. 8.133

Dimensions: wall th.: 0.8 cm; base diam.: 35 cm; base th.: 0.8 cm.

Clay: outer, inner and fabric colour: 7.5YR 5/6 (strong brown); sand inclusions; medium firing temperature.

Description: flat base.

Catalogue of US 152 Finds

*Objects***AbT.13.49 - Fig. 8.119**

Description: chert flake.

Dimensions: 5.4x6.6x2.7 cm.

*Pottery***AbT.13.152.1 - Fig. 8.133**

Dimensions: rim diam.: 36 cm; rim th.: 2 cm; wall th.: 1.2 cm.

Clay: outer colour: 2.5Y 4/4 (olive brown); inner colour: 2.5Y 7/4 (pale brown); fabric colour: 10YR 6/4 (light yellowish brown); sand inclusions; medium firing temperature.

Description: triangular rim bowl.

AbT.13.152.2 - Fig. 8.133

Dimensions: rim diam.: 20 cm ca.; rim th.: 1.5 cm; wall th.: 1.1 cm.

Clay: outer colour: 10YR 8/3 (very pale brown); inner colour: 10YR 7/4 (very pale brown); fabric colour: 10YR 6/4 (light yellowish brown); sand inclusions; medium firing temperature.

Description: triangular rim bowl.

AbT.13.152.3 - Fig. 8.133

Dimensions: rim diam.: 36 cm ca. (inner); rim th.: 1.7 cm; wall th.: 0.8 cm.

Clay: outer and inner colour (self-slip): 2.5Y 8/2 (pale brown); fabric colour: 7.5YR 6/4 (light brown); sand inclusions; medium-high firing temperature.

Description: triangular rim bowl.

AbT.13.152.4 - Fig. 8.133

Dimensions: rim diam.: 14 cm (inner); rim th.: 0.9 cm; wall th.: 0.7 cm.

Clay: outer and inner colour: 2.5Y 8/3 (pale brown); fabric colour: 7.5YR

6/6 (reddish yellow); sand inclusions; medium firing temperature.
Description: band rim jar.

AbT.13.152.5 - Fig. 8.133

Dimensions: rim diam.: 18 cm (inner); rim th.: 1.5 cm; wall th.: 0.7 cm.
Clay: outer and inner colour: 2.5Y 8/3 (pale brown); fabric colour: 10YR 6/4 (light yellowish brown); sand inclusions; medium firing temperature.
Description: band rim jar.

AbT.13.152.6 - Fig. 8.133

Dimensions: rim diam.: 15 cm; rim th.: 1.3 cm; wall th.: 0.8 cm.
Clay: outer colour: 10YR 7/4 (pale brown); inner colour: 10YR 8/2 (very pale brown); fabric colour: 7.5YR 6/4 (light brown); sand inclusions; medium firing temperature.
Description: band rim jar.

AbT.13.152.7 - Fig. 8.133

Dimensions: wall th.: 1 cm; base diam.: 18 cm; base th.: 1 cm.
Clay: outer and inner colour: 2.5Y 7/4 (pale brown); fabric colour: 7.5YR 6/4 light brown; sand and vegetal inclusions; medium firing temperature.
Description: ring base.

AbT.13.152.8 - Fig. 8.133

Dimensions: rim diam.: 10 cm; rim th.: 0.2 cm; wall th.: 0.7 cm; base diam.: 5 cm; base th.: 0.9 cm; h.: 10.5 cm.
Clay: outer colour: 2.5Y 8.5/2 (pale yellow); inner colour: 2.5Y 8/2 (pale brown); fabric colour: 5YR 6/4 (light reddish brown); sand inclusions; medium firing temperature.
Description: beaker.

AbT.13.152.9 - Fig. 8.133

Dimensions: rim diam.: 20 cm; rim th.: 1.4 cm; wall th.: 0.9 cm.
Clay: outer colour: 10YR 8/3 (very pale brown); inner colour: 2.5Y 8/2 (pale brown); fabric colour: 10YR 6/4 (light yellowish brown); sand inclusions; medium firing temperature.
Description: triangular rim bowl.

AbT.13.152.10 - Fig. 8.133

Dimensions: rim diam.: 18 cm; rim th.: 0.8 cm; wall th.: 0.6 cm.
Clay: outer colour (self-slip): 5YR 6/4 (light reddish brown); inner colour: 10YR 8/3 (very pale brown); fabric colour: 10YR 5/4 (yellowish brown);

sand inclusions; medium-low firing temperature.
Description: plain rim jar.

AbT.13.152.11 - Fig. 8.133

Dimensions: rim diam.: 16 cm; rim th.: 0.8 cm; wall th.: 0.6 cm.
Clay: outer colour: 2.5Y 8/2 (pale brown); inner colour: 10YR 7/3 (very pale brown); fabric colour: 10YR 6/4 (light yellowish brown); sand inclusions; medium-low firing temperature.
Description: plain rim jar.

AbT.13.152.12 - Fig. 8.133

Dimensions: rim diam.: 9 cm; rim th.: 1.1 cm; wall th.: 0.6 cm.
Clay: outer and inner colour: 5Y 8/2 (pale yellow); fabric colour: 7.5YR 6/4 (light brown); sand inclusions; medium-low firing temperature.
Description: triangular rim jar.

AbT.13.152.13 - Fig. 8.133

Dimensions: wall th.: 1.1 cm; base diam.: 20 cm; base th.: 1.9 cm.
Clay: outer colour (slip): 10YR 8.5/2 (very pale brown); inner colour: 7.5YR 6/6 (reddish yellow); fabric colour: 7.5YR 6/4 (light brown); sand inclusions; medium-high firing temperature.
Description: stemmed-dish base with hatched decoration.

AbT.13.152.14 - Fig. 8.133

Dimensions: rim diam.: 15 cm; rim th.: 0.9 cm; wall th.: 0.75 cm.
Clay: outer and inner colour: 7.5YR 8/3 (pink); fabric colour: 5YR 5/4 (reddish brown); sand inclusions; medium firing temperature.
Description: band rim jar.

AbT.13.152.15 - Fig. 8.133

Dimensions: wall th.: 1 cm.
Clay: outer and inner colour: 10YR 8/2 (very pale brown); fabric colour: 7.5YR 7/4 (pink); sand inclusions; medium firing temperature.
Description: jar shoulder fragment with notched ridge and incised decoration above it.

AbT.13.152.16 - Fig. 8.133

Dimensions: wall th.: 0.6 cm.
Clay: outer and inner colour: 10YR 8/2 (very pale brown); fabric colour: 7.5YR 7/4 (pink); sand inclusions; medium firing temperature.

Description: jar shoulder fragment with notched ridge and a single wavy incision above it.

AbT.13.152.17 - Fig. 8.133

Dimensions: wall th.: 1 cm; base diam.: 5.4 cm.
Clay: outer, inner and fabric colour: 7.5YR 6/4 (light brown); sand inclusions; medium firing temperature.
Description: body of a small jar with string-cut base, rounded shoulders and ovoid body.

AbT.13.152.18 - Fig. 8.133

Dimensions: wall th.: 1 cm; base diam.: 3.4 cm; base th.: 0.6 cm.
Clay: outer and inner colour: 7.5YR 6/4 (light brown); fabric colour: 10YR 7/4 (very pale brown); sand inclusions; medium firing temperature.
Description: pointed base.

AbT.13.152.19 - Fig. 8.133

Dimensions: wall th.: 2.1 cm; base diam.: 40 cm ca.; base th.: 2 cm.
Clay: outer and inner colour: 7.5YR 7/4 (pink); fabric colour: 7.5YR 6/4 (light brown); sand and vegetal inclusions; medium firing temperature.
Description: flat base.

AbT.13.152.20 - Fig. 8.133

Dimensions: wall th.: 0.5 cm; base diam.: 5.4 cm; base th.: 0.8 cm.
Clay: outer colour: 10YR 8/2 (very pale brown); inner colour: 7.5YR 7/4 (pink); fabric colour: 7.5YR 6/4 (light brown); sand inclusions; medium firing temperature.
Description: rounded base.

AbT.13.152.21 - Fig. 8.133

Dimensions: wall th.: 0.9 cm; base diam.: 11 cm; base th.: 0.9 cm.
Clay: outer colour: 2.5Y 5/1 (grey); inner and fabric colour: 5Y 6/1 (grey); sand inclusions; medium firing temperature.
Description: flat base.

AbT.13.152.22 - Fig. 8.133

Dimensions: wall th.: 0.8 cm; base diam.: 20 cm; base th.: 1 cm.
Clay: outer colour: 10YR 8/2 (very pale brown); inner colour: 7.5YR 8/2 (pink); fabric colour: 7.5YR 6/4 (light brown); sand inclusions; medium firing temperature.

Description: convex base with three feet.

Catalogue of US 163 Finds

Objects

AbT.13.66 - Fig. 8.120

Description: copper alloy fragment.
Dimensions: 1.8x3.1x0.9 cm.

AbT.13.67 - Fig. 8.120

Description: carnelian fragment.
Dimensions: 1.6x2x0.9 cm.

AbT.13.68 - Fig. 8.120

Description: clay wheel pierced in the middle.
Dimensions: 3 cm (perforation's diameter); 10.5x6.8 cm.

Pottery

AbT.13.163.1 - Fig. 8.134

Dimensions: rim diam.: 9 cm ca.; rim th.: 0.5 cm; wall th.: 0.8 cm; base diam.: 4.5 cm; base th.: 1 cm; h.: 8.8 cm.
Clay: outer, inner and fabric colour: 5YR 4/4 (reddish brown); sand inclusions; medium-low firing temperature.
Description: small beaker.

AbT.13.163.2 - Fig. 8.134

Dimensions: rim diam.: 14 cm; rim th.: 0.7 cm; wall th.: 1.1 cm; base diam.: 5 cm; base th.: 0.9 cm; h.: 7.8 cm.
Clay: outer colour: 10YR 6/4 (light yellowish brown); inner colour: 5YR 4/4 (reddish brown); fabric colour: 7.5YR 5/6 (strong brown); sand inclusions; medium firing temperature.
Description: conical bowl.

AbT.13.163.3 - Fig. 8.134

Dimensions: rim diam.: 12 cm; rim th.: 0.5 cm; wall th.: 0.6 cm; base diam.: 5 cm; base th.: 0.8 cm; h.: 6.6 cm.
Clay: outer and inner colour: 2.5Y 8/3 (pale brown); fabric colour: 7.5YR 5/6 (strong brown); sand inclusions; medium firing temperature.
Description: conical bowl.

AbT.13.163.4 - Fig. 8.134

Dimensions: wall th.: 0.7 cm; base diam.: 3 cm; base th.: 0.8 cm.

Clay: outer, inner and fabric colour: 7.5YR 4/4 (brown); sand inclusions; medium-low firing temperature.
Description: pointed base.

AbT.13.163.5 - Fig. 8.134

Dimensions: rim diam.: 23 cm; rim th.: 0.8 cm; wall th.: 0.8 cm.
Clay: outer and inner colour: 2.5Y 4/1 (dark grey); fabric colour: 5Y 5/1 (grey); sand inclusions; medium firing temperature.
Description: drinking vessel rim.

AbT.13.163.6 - Fig. 8.134

Dimensions: rim diam.: 18 cm; rim th.: 0.6 cm; wall th.: 0.9 cm.
Clay: outer and inner colour: 2.5Y 4/1 (dark grey); fabric colour: 5Y 5/1 (grey); sand inclusions; medium firing temperature.
Description: drinking vessel rim.

AbT.13.163.7 - Fig. 8.134

Dimensions: rim diam.: 40 cm; rim th.: 2,1 cm; wall th.: 1.2 cm.
Clay: outer and inner colour: 7.5YR 5/6 (strong brown); fabric colour: 10YR 5/4 (yellowish brown); sand inclusions; medium firing temperature.
Description: triangular rim bowl.

AbT.13.163.8 - Fig. 8.134

Dimensions: rim diam.: 36 cm; rim th.: 1.9 cm; wall th.: 1.2 cm.
Clay: outer, inner and fabric colour: 7.5YR 5/6 (strong brown); sand inclusions; medium firing temperature.
Description: triangular rim bowl.

AbT.13.163.9 - Fig. 8.134

Dimensions: rim diam.: 36 cm; rim th.: 1.3 cm; wall th.: 1.3 cm.
Clay: outer colour: 10YR 6/4 (light yellowish brown); inner colour: 7.5YR 6/6 (reddish yellow); fabric colour: 7.5YR 4/4 (brown); sand inclusions; medium firing temperature.
Description: stemmed-dish bowl.

AbT.13.163.10 - Fig. 8.134

Dimensions: rim diam.: 26 cm; rim th.: 2.1 cm; wall th.: 1 cm.
Clay: outer and inner colour: 7.5YR 6/6 (reddish yellow); fabric colour: 7.5YR 4/4 (brown); sand inclusions; medium firing temperature.
Description: triangular rim bowl.

AbT.13.163.11 - Fig. 8.134

Dimensions: rim diam.: 23 cm; rim th.: 2.2 cm; wall th.: 1.2 cm.
Clay: outer colour: 10YR 6/4 (light yellowish brown); inner colour: 5YR 5/6 (yellowish red); fabric colour: 7.5YR 5/4 (brown); sand inclusions; medium firing temperature.
Description: triangular rim bowl.

AbT.13.163.12 - Fig. 8.134

Dimensions: rim diam.: 27 cm; rim th.: 2.1 cm; wall th.: 1 cm.
Clay: outer colour (self-slip): 10YR 8/2 (very pale brown); inner colour: 7.5YR 6/6 (reddish yellow); fabric colour: 7.5YR 5/6 (strong brown); sand inclusions; medium firing temperature.
Description: triangular rim bowl.

AbT.13.163.13 - Fig. 8.134

Dimensions: rim diam.: 16 cm; rim th.: 1 cm; wall th.: 0.7 cm.
Clay: outer colour: 2.5Y 8/3 (pale brown); inner colour: 10YR 8/3 (very pale brown); fabric colour: 7.5YR 6/4 (light brown); sand inclusions; medium-high firing temperature.
Description: stemmed-dish bowl.

AbT.13.163.14 - Fig. 8.134

Dimensions: rim diam.: 31 cm; rim th.: 1.8 cm; wall th.: 2.6 cm; base diam.: 30 cm; base th.: 1.8 cm; h.: 9 cm.
Clay: outer and inner colour: 7.5YR 4/6 (strong brown); fabric colour: 2.5Y 3/1 (very dark grey); sand and vegetal inclusions; medium-low firing temperature.
Description: tray.

AbT.13.163.15 - Fig. 8.134

Dimensions: wall th.: 0.7 cm.
Clay: outer colour: 7.5YR 7/3 (pink); inner and fabric colour: 5YR 6/6 (reddish yellow); sand inclusions; medium firing temperature.
Description: cylinder with shaved walls.

AbT.13.163.16 - Fig. 8.134

Dimensions: rim diam.: 16 cm ca.; rim th. 0.4 cm; wall th.: 0.5 cm.
Clay: outer colour: 7.5YR 7/3 (pink); inner colour: 10YR 8/2 (very pale brown); fabric colour: 7.5YR 5/4 (brown); sand inclusions; medium-high firing temperature.
Description: plain rim with two lines of wavy decoration on the outer surface.

AbT.13.163.17 - Fig. 8.134

Dimensions: rim diam.: 16 cm; rim th.: 1.2 cm; wall th.: 0.9 cm.

Clay: outer colour: 10YR 5/4 (yellowish brown); inner colour: 10YR 6/4 (light yellowish brown); fabric colour: 7.5YR 5/6 (strong brown); sand inclusions; medium firing temperature. Description: band rim jar.

AbT.13.163.18 - Fig. 8.134

Dimensions: rim diam.: 17 cm; rim th.: 0.7 cm; wall th.: 0.7 cm.

Clay: outer and inner colour: 5Y 7/3 (pale yellow); fabric colour: 7.5YR 4/6 (strong brown); sand inclusions; medium firing temperature. Description: band rim jar.

AbT.13.163.19 - Fig. 8.134

Dimensions: wall th.: 1.4 cm.

Clay: outer and inner colour (self-slip): 2.5Y 8/3 (pale brown); fabric colour: 7.5YR 6/6 (reddish yellow); sand inclusions; medium firing temperature. Description: jar shoulder decorated with oblique incisions, one applied notched ridge and traces of incised waved lines.

AbT.13.163.20 - Fig. 8.134

Dimensions: wall th.: 2 cm; base diam.: 12 cm; base th.: 1.3 cm.

Clay: outer, inner and fabric colour: 5YR 4/4 (reddish brown); sand and vegetal inclusions; medium firing temperature.

Description: coarse fabric stand with a hole (diameter 1.8 cm) and three small feet at the centre of the ring (?) base. It could be considered also inverted.

AbT.13.163.21 - Fig. 8.134

Dimensions: wall th.: 1 cm; base diam.: 22 cm; base th.: 0.9 cm.

Clay: outer and inner colour: 2.5Y 7/4 (pale brown); fabric colour: 10YR 6/4 (light yellowish brown); sand inclusions; medium firing temperature. Description: ring base.

AbT.13.163.22 - Fig. 8.134

Dimensions: rim diam.: 16 cm; rim th.: 0.6 cm; wall th.: 1 cm; base diam.: 5.3 cm; base th.: 1.5 cm; h.: 7.7 cm.

Clay: outer, inner and fabric colour: 7.5YR 6/4 (light brown); sand inclusions; medium-low firing temperature.

Description: conical bowl. Found near the lower limbs of the body.

AbT.13.163.23 - Fig. 8.134

Dimensions: rim diam.: 14 cm; rim th.: 0.8 cm; wall th.: 0.7 cm.

Clay: outer colour: 2.5Y 8/2 (pale brown); inner colour: 7.5YR 6/4 (light brown); fabric colour: 7.5YR 5/4 (brown); sand inclusions; medium firing temperature.

Description: band rim jar.

AbT.13.163.24 - Fig. 8.134

Dimensions: rim diam.: 13 cm; rim th.: 0.9 cm; wall th.: 0.5 cm.

Clay: outer and inner colour (self-slip): 2.5Y 8/2 (pale brown); fabric colour: 7.5YR 6/4 (light brown); sand inclusions; medium firing temperature. Description: plain rim jar.

AbT.13.163.25 - Fig. 8.134

Dimensions: wall th.: 1 cm.

Clay: outer and inner colour: 10YR 8/2 (very pale brown); fabric colour: 7.5YR 6/4 (light brown); sand inclusions; medium firing temperature. Description: wall fragment with an applied notched ridge.

AbT.13.163.26 - Fig. 8.134

Dimensions: rim diam.: 15 cm; rim th.: 0.6 cm; wall th.: 0.8 cm; base diam.: 4.8 cm; base th.: 1.2 cm; h.: 8.2 cm.

Clay: outer and inner colour: 5Y 8/2 (pale yellow); fabric colour: 5YR 6/3 (pale olive); sand inclusions; medium firing temperature.

Description: conical bowl.

AbT.13.163.27 - Fig. 8.134

Dimensions: wall th.: 1 cm.

Clay: outer colour: 2.5Y 8/2 (pale brown); inner colour: 10YR 8/2 (very pale brown); fabric colour: 5YR 6/6 (reddish yellow); sand inclusions; medium firing temperature.

Description: shoulder fragment of a jar with 15 incised parallel lines.

AbT.13.163.28 - Fig. 8.134

Dimensions: wall th.: 0.5 cm; base diam.: 18.6 cm; base th.: 1 cm.

Clay: outer, inner and fabric colour: not registered; sand inclusions; medium-high firing temperature.

Description: ring base jar with bitumen traces (drops), perhaps a sort of simple decoration that occupies only half of

the base. The decoration was clearly applied with the jar set upside-down. The jar contained fragments from AbT.13.163.29 to AbT.13.163.40.

AbT.13.163.29 - Fig. 8.134

Dimensions: wall th.: 1.3 cm; base diam.: 6 cm; base th.: 0.9 cm.

Clay: outer, inner and fabric colour: 5Y 8/2 (pale yellow); sand inclusions; medium-high firing temperature.

Description: beaker base. Inside jar AbT.13.163.28.

AbT.13.163.30 - Fig. 8.134

Dimensions: wall th.: 1.3 cm; base diam.: 7 cm; base th.: 0.9 cm.

Clay: outer and fabric colour: 10YR 6/4 (light yellowish brown); inner colour: 7.5YR 5/4 (brown); sand inclusions; medium firing temperature.

Description: beaker base. Inside jar AbT.13.163.28.

AbT.13.163.31 - Fig. 8.134

Dimensions: wall th.: 0.9 cm; base diam.: 5.3 cm; base th.: 0.8 cm.

Clay: outer colour: 7.5YR 7/3 (pink); inner colour: 7.5YR 6/4 (light brown); fabric colour: 7.5YR 5/4 (brown); sand inclusions; medium-high firing temperature.

Description: beaker base. Inside jar AbT.13.163.28.

AbT.13.163.32 - Fig. 8.134

Dimensions: wall th.: 1 cm; base diam.: 5.3 cm; base th.: 0.7 cm.

Clay: outer and inner colour: 7.5YR 8/3 (pink); fabric colour: 7.5YR 5/4 (brown); sand inclusions; medium-low firing temperature.

Description: beaker base. Inside jar AbT.13.163.28.

AbT.13.163.33 - Fig. 8.134

Dimensions: wall th.: 1.1 cm; base diam.: 5 cm; base th.: 1.2 cm.

Clay: outer colour: 10YR 8.5/2 (very pale brown); inner colour: 10YR 7/4 (very pale brown); fabric colour: 7.5YR 5/4 (brown); sand inclusions; medium firing temperature.

Description: beaker base. Inside jar AbT.13.163.28.

AbT.13.163.34 - Fig. 8.134

Dimensions: wall th.: 0.8 cm; base diam.: 5 cm; base th.: 1 cm.

Clay: outer, inner and fabric colour: 7.5YR 6/4 (light brown); sand inclusions; medium-low firing temperature.

Description: conical bowl base. Inside jar AbT.13.163.28.

AbT.13.163.35 - Fig. 8.134

Dimensions: wall th.: 0.8 cm; base diam.: 5 cm; base th.: 1 cm.

Clay: outer, inner and fabric colour: 10YR 6/4 (light yellowish brown); sand inclusions; medium firing temperature.

Description: conical bowl base. Inside jar AbT.13.163.28.

AbT.13.163.36 - Fig. 8.134

Dimensions: wall th.: 1 cm; base diam.: 5.5 cm; base th.: 0.8 cm.

Clay: outer, inner and fabric colour: 7.5YR 6/4 (light brown); sand inclusions; medium-low firing temperature.

Description: conical bowl base. Inside jar AbT.13.163.28.

AbT.13.163.37 - Fig. 8.134

Dimensions: wall th.: 1 cm; base diam.: 5 cm; base th.: 1.1 cm.

Clay: outer, inner and fabric colour: 7.5YR 6/4 (light brown); sand inclusions; medium-high firing temperature.

Description: conical bowl base. Inside jar AbT.13.163.28.

AbT.13.163.38 - Fig. 8.134

Dimensions: wall th.: 1 cm; base diam.: 5 cm; base th.: 1.1 cm.

Clay: outer and inner colour: 2.5Y 8/2 (pale brown); fabric colour: 5YR 6/6 (reddish yellow); sand inclusions; medium firing temperature.

Description: conical bowl base. Inside jar AbT.13.163.28.

AbT.13.163.39 - Fig. 8.134

Dimensions: wall th.: 0.7 cm; base diam.: 5 cm; base th.: 1.4 cm.

Clay: outer, inner and fabric colour: 5YR 6/6 (reddish yellow); sand inclusions; medium-low firing temperature.

Description: conical bowl base. Inside jar AbT.13.163.28.

AbT.13.163.40 - Fig. 8.134

Dimensions: wall th.: 0.7 cm; base diam.: 6 cm; base th.: 0.6 cm.

Clay: outer, inner and fabric colour: 2.5Y 5/2 (greyish brown); sand

inclusions; medium-low firing temperature.

Description: conical bowl base. Inside jar AbT.13.163.28.

Catalogue of US 166 Finds

Objects

AbT.13.62 - Fig. 8.121

Description: chert sickle element.

Dimensions: 3.4x1.2x0.4 cm.

Catalogue of US 167 Finds

Objects

AbT.13.62 - Fig. 8.122

Description: stone vessel fragment with very slight abrasion traces on the internal surface, whereas the outer surface presents heavier vertical abrasion traces. [SC]

Dimensions: 1.5x7 cm ca.

Pottery

AbT.13.167.1 - Fig. 8.135

Dimensions: wall th.: 1.2 cm; base diam.: 6.8 cm; base th.: 1 cm.

Clay: outer and inner colour: 2.5Y 8/3 (pale brown); fabric colour: 10YR 6/4 (light yellowish brown); sand inclusions; medium firing temperature.

Description: cylinder.

Catalogue of US 200 Finds

Objects

AbT.12.16 - Fig. 8.123

Description: chert sickle element.

Dimensions: 1.2x4x0.3 cm.

Pottery

AbT.14.200.1 - Fig. 8.135

Dimensions: wall th.: 1.3 cm; base diam.: 7 cm; base th.: 1.1 cm

Clay: outer, inner and fabric colour: 2.5YR 5/6 (red); sand inclusions; medium firing temperature.

Description: conical bowl.

AbT.14.200.2 - Fig. 8.135

Dimensions: rim diam.: 15.5 cm; rim th.: 0.7 cm; wall th.: 0.6 cm.

Clay: outer, inner and fabric colour: 7.5YR 8/2 (pinkish white); sand inclusions; medium firing temperature.

Description: band rim jar.

AbT.14.200.3 - Fig. 8.135

Dimensions: rim diam.: 17.3 cm; rim th.: 0.4 cm; wall th.: 0.8 cm; base diam.: 5 cm; base th.: 1.2 cm; h.: 7.4 cm.

Clay: outer, inner and fabric colour: 5YR 6/4 (light reddish brown); sand inclusions; medium firing temperature.

Description: conical bowl.

AbT.14.200.4 - Fig. 8.135

Dimensions: rim diam.: 14.4 cm; rim th.: 0.4 cm; wall th.: 0.7 cm; base diam.: 5.4 cm; base th.: 1 cm; h.: 7.4 cm.

Clay: outer, inner and fabric colour: 7.5YR 6/4 (light brown); sand inclusions; medium firing temperature.

Description: conical bowl.

AbT.14.200.5 - Fig. 8.135

Dimensions: rim diam.: 14.2 cm; rim th.: 0.4 cm; wall th.: 0.7 cm; base diam.: 4.5 cm; base th.: 0.7 cm; h.: 7.7 cm.

Clay: outer, inner and fabric colour: 7.5YR 8/2 (pinkish white); sand inclusions; medium firing temperature.

Description: conical bowl.

