

# A MULTI-PHYSICS APPROACH TO SIMULATE THE RF-HEATING 3D POWER MAP INDUCED BY THE PROTON BEAM IN A BEAM INTERCEPTING DEVICE\*

L. Teofili<sup>†,1,2</sup>, M. Migliorati<sup>1,2</sup>, Sapienza University of Rome, Rome, Italy  
 D. Carbajo, F. Giordano, I. Lamas, G. Mazzacano, CERN, Geneva, Switzerland  
<sup>1</sup>also at CERN, Geneva, Switzerland; <sup>2</sup>also at INFN, Rome, Italy

## Abstract

The project High Luminosity Large Hadron Collider (HL-LHC) calls for a streaking beam intensity and brightness in the LHC machine. In such a scenario, beam-environment electromagnetic interactions are a crucial topic: they could lead to uneven power deposition in machine equipment. The resulting irregular temperature distribution would generate local thermal gradients, this would create mechanical stresses which could lead to cracks and premature failure of accelerator devices. This work presents a method to study this phenomenon by means of coupled electro-thermo-mechanical simulations. Further, an example of application on a real HL-LHC device is also discussed.

## INTRODUCTION

Beam induced RF-Heating on machine systems, i.e. the heat load due to electromagnetic interactions between particles beam and equipment, is a crucial issue for high intensity/brightness particle accelerators. Taking as example the LHC, RF-Heating imposed severe limitations on its first operational run (2009-2013); some devices were damaged and numerous actions had to be taken to reduce the RF-Heating detrimental effects [1].

Well established results [2], show that the beam-equipment interaction causes a total power deposition proportional to the square of the beam intensity and to the real part of the device impedance according to:

$$\Delta P = (f_0 e N_{beam})^2 \sum_{p=-\infty}^{p=+\infty} |\Lambda(p\omega_0)|^2 \text{Re}[Z_{||}(p\omega_0)] \quad (1)$$

Where  $N_{beam}$  is the beam intensity,  $e$  is the elementary charge,  $f_0$  is the revolution frequency of the beam and  $\omega_0 = 2\pi f_0$ ,  $\Lambda$  is the normalized beam spectrum and  $\text{Re}[Z_{||}]$  is the real part of the longitudinal coupling impedance.

RF-Heating is split in two contributions:

- Resistive wall impedance (RWI) heating. This phenomenon distributes the heat flux regularly on the device walls according to the electric conductivity of the material and to the inverse of the beam-wall distance.
- High Order Modes (HOM) heating. Due to the presence of trapped electromagnetic resonant modes in a device, the heat flux is distributed in a highly irregular way dependent on the mode.

As a result, while RWI generates smooth temperature maps, HOMs can lead to an uneven temperature distribution. Temperature gradients or power deposition in unexpected areas may induce intense mechanical stresses that can cause failures, or generate other undesired effects as material damage [3]. With the increase in beam intensity in the next generation of particle accelerators, the phenomenon has become a crucial issue for equipment design, particularly, for the Beam Intercepting Devices (BIDs) as collimators or scrapers which work in close proximity to the particle beam, and can suffer of severe HOM and RWI heating.

Thus, a method that allows to simulate accurately the thermo-mechanical effects of the RF-heating would be extremely helpful in BIDs design. However, at present, just few studies deal with this problem [3, 4]. In this context, this paper presents a rigorous way to obtain a 3D map of the HOMs RF-heating and explains how to take into account the RWI effects, to simulate their thermal and mechanical effects on accelerator devices. Further, it presents a practical application of the method on a BID.

## METHODOLOGY

The current investigation defines a procedure to interface the two commercial programs CST studio suite<sup>®</sup> [5] and ANSYS mechanical<sup>®</sup> [6]. These tools are well known and tested at CERN: CST studio suite<sup>®</sup> is a standard for device impedance computations [7, 8], while ANSYS mechanical<sup>®</sup> is widely used for structural and thermal analysis [9–12]. The former simulates the RF-Heating map that is subsequently imported in the latter to calculate thermal and mechanical effects.

The entire procedure is depicted in Fig. 1. There are three main macro-areas: Electromagnetic Simulations (A, B and C blocks for HOM heating and F input for RWI heating), CST<sup>®</sup>, Beam Power Dissipation and Interface (D and E blocks), Thermomechanical Simulations (G block), ANSYS<sup>®</sup>. Every macro-areas is divided in sub-blocks. Each of them is explained taking as example the analysis done on the Target Dump Injection Segmented (TDIS) [13]. The TDIS is a BID that will protect LHC downstream equipment during the injection phase, absorbing the injected beam in case of a misfiring injection kicker [14].

### A, Eigenmode Simulations

The device CAD model for production is taken as geometry model for the electromagnetic simulations once simplified. Only the electromagnetic important elements should be

\* Work supported by LHC Injection Upgrade (LIU)

<sup>†</sup> lorenzo.teofili@uniroma1.it

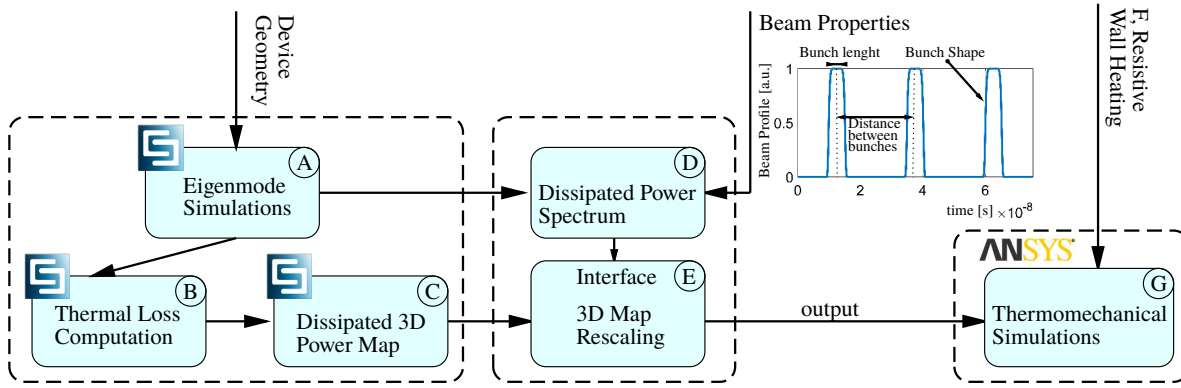

Figure 1: Block diagram of the methodology with some of the beam properties.

considered (screws, little grooves, small surfaces should be removed, see Fig. 2 for example), in order to obtain the balance between accuracy of the model and simulation speed. Subsequently, the presence of trapped HOM in the device is investigated through the CST eigenmode solver [15]. The solver provide for each of them the resonating frequency  $f_m$ , the quality factor  $Q$ , the Shunt impedance  $R_s$ , the local value of electric and magnetic fields and the surface currents in the entire geometry [16]. Since the beam can excite only the first  $N$  modes in its spectrum bandwidth, henceforth, only they should be considered.

### B, Thermal Loss Computation

By processing the data from eigenmode, the local dissipated power for each mode can be obtained. CST<sup>®</sup> considers power losses per unit volume due to Joule effects in dielectric materials ( $\mathcal{D}$ ), Eq. (2), [17]. While using the flux of the real part of the Poynting vector, Eq. (3), it computes the power which flows and is dissipated within the walls of good conductors ( $C$ ) [16].

$$P(x, y, z, f_m) = \sigma E_{rms}^2(x, y, z, f_m) \quad (2)$$

$$P(x, y, z, f_m) = \sqrt{\frac{\pi f_m \mu_0}{4\sigma}} |\mathbf{H}_t(x, y, z, f_m)|^2 \quad (3)$$

Where  $\sigma$  is the electric conductivity of the material,  $E_{rms}$  is the root mean square value of the local electric field,  $\mathbf{H}_t$  is the local surface current vector and  $\mu_0$  is the vacuum permeability.

### C, Dissipated 3D Power Map

The results of the previous step can be mapped into the device model geometry using the CST thermal solver<sup>®</sup> [18]. This generates a 3D map of the power dissipated on the device by each HOM. However, the map does not take into account the properties of the real beam that is passing through the device: beam revolution frequency  $f_0$  and intensity  $N_{beam}$ , bunch shape, bunch length, distance between bunches and number of bunches, see Fig. 2 top right detail. Indeed, the eigenmode solver calculates the electromagnetic field pattern solving an eigenmode problem with

no excitation applied [19]. This implies that, while the 3D dissipated power distribution on the device is correct, the local absolute value is not. There is a scale factor between the power dissipated by the actual beam and the one computed by the eigenmode solver.

### D, Dissipated Power Spectrum

To obtain this scale factor the real beam characteristic are considered to compute the beam spectrum  $\Lambda(f)$  and so the the deposited power  $\Delta P(f)$  by Eq. (4), [2]:

$$\Delta P(f) = (f_0 e N_{beam})^2 |\Lambda(f)|^2 \text{Re}[Z_{||}(f)], \quad (4)$$

where  $f$  is a generic frequency. Furthermore, a sensitivity analysis of the impedance induced power should be performed. The real part of the device impedance is obtained for every mode considering its Q factor, its Shunt impedance and its resonating frequency from Eq. (5), [20], where  $i = \sqrt{-1}$ .

$$Z_{||}(f) = \frac{R_s}{1 + iQ(\frac{f_m}{f} - \frac{f}{f_m})} \quad (5)$$

Then, the impedance profile of each mode is singly moved within an arbitrary frequency range to maximise the coupling between beam spectrum and impedance, i.e. the maximum induced power loss. This is the value considered as total power dissipated by the beam at the mode frequency  $\Delta P(f_m)$ . The frequency tolerance can be set considering the geometrical simplifications done to the CAD model, as example we

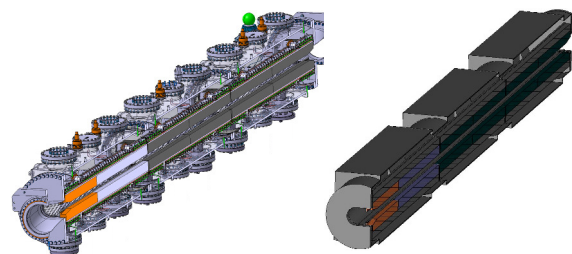

Figure 2: CAD model and simplified TDIS model.

Content from this work may be used under the terms of the CC BY 3.0 licence (© 2018). Any distribution of this work must maintain attribution to the author(s), title of the work, publisher, and DOI.

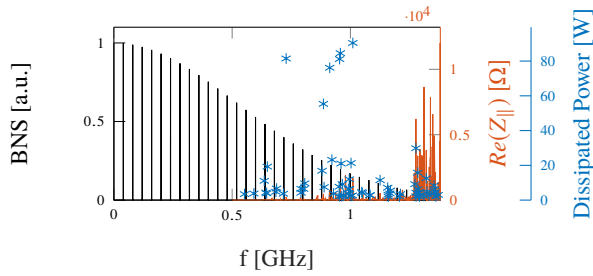

Figure 3: Power spectrum, Beam normalized spectrum (BNS) and longitudinal impedance real part, in different scales, refer to colors.

used  $\pm 10 MHz$  for the TDIS. Figure 3 shows the TDIS longitudinal impedance, the HL-LHC beam normalized spectrum (BNS) and the dissipated power spectrum.

### E, 3D Map Rescaling

For every mode, the 3D power map distribution,  $P(x, y, z)$ , is rescaled and added to the contributions of the other HOMs, according to the following relation:

$$P_{HOM}(x, y, z) = \sum_{m=1}^{m=N} \Delta P(f_m) K_m P(x, y, z, f_m) \quad (6)$$

where  $N$  is the number of HOMs considered and

$$K_m = \frac{1}{\iint_D P(x, y, z, f_m) dV + \iint_C P(x, y, z, f_m) dS} \quad (7)$$

is the inverse of the total dissipated power computed by the CST eigenmode solver. Thus, in Eq. (6),  $K_m P(x, y, z, f_m)$  is the unit 3D dissipated power map for the mode i.e. its integral on the whole device is one. Subsequently, multiplying by the expected dissipated power for that mode ( $\Delta P(f_m)$ ), the 3D power map with the local correct absolute values of the dissipated power is obtained. Finally, the heating contribution of every HOM is summed in order to have the 3D map of the total heating flux  $P_{HOM}$ .

### F, The Resistive Wall Impedance Heating

In accelerators, in general, one wants to have good conductors in close proximity to the beam to limit impedance. In such a case, the total RWI heating can be taken into account using Eq. (1), considering only the broad band part of the longitudinal impedance obtained by the CST wakefiled solver<sup>®</sup> [21]. The power is then distributed as a heat flux in the geometry according to the beam-wall distance and the electric conductivity of the wall material. This contribution is added to the HOM heating  $P_{HOM}$ . An example of the RWI heating map for the Proton Synchrotron Booster Absorber Scraper (PSBAS) can be found in the work of Teofili et al. [22].

### G, Output and Thermo-mechanical Simulations

The map  $P_{HOM}$  is imported in the ANSYS workbench<sup>®</sup> and mapped as a surface heat load for good conductors or

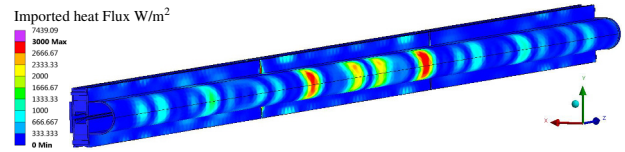

Figure 4: Example of a mode RF-HOM Heating map imported in ANSYS<sup>®</sup>, for the TDIS core components.

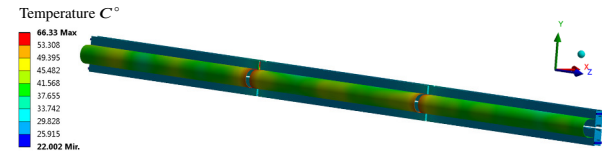

Figure 5: Global Temperature distribution of the TDIS.

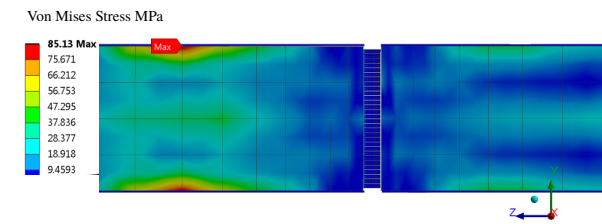

Figure 6: Maximum mechanical stresses in the TDIS.

as volume heat load for dielectrics to perform the thermo-mechanical simulations. The same geometrical model of the electromagnetic simulations was used with slight modifications. An example of imported power map for the TDIS is shown in Fig. 4. As validation a steady state thermal simulations is done, the heating source is set as the  $P_{HOM}$  map along with a fictitious convection on all the bodies. If the RF heat load is correctly imported the power evacuated by the convection must be the one expected from Eq. (1).

## RESULTS

Such a method was applied to test the design quality of two different BIDs: the PSBAS [22], and the TDIS [23]. As example of the achievable results of the method, we report the temperature distribution and the mechanical stresses on the TDIS, Fig. 5 and 6.

## CONCLUSION

In this study, we illustrated an accurate multiphysics approach to simulate the RF-Heating mechanical and thermal effects on accelerator devices. We explained its work flow and we showed examples of its use. As expected, the method revealed possible critical points of the design providing temperature and stresses maps. Future work will benchmark simulation results against measurements on physical devices to fully validate the method. We believe that this could be a key approach to deal with RF-heating design problems of future high intensity, low emittance hadron accelerators.

This is a preprint — the final version is published with IOP

## REFERENCES

- [1] B. Salvant *et al.*, “Beam Induced RF Heating in LHC in 2005”, in *Proc. 7th Int. Particle Accelerator Conf. (IPAC'16)*, Busan, Korea, May 2016, paper MOPOR008, pp. 602–605.
- [2] M. Furman, H. Lee and B. Zotter, “Energy loss of bunched beams in RF cavities”, Lawrence Berkeley Laboratory, Berkeley, California, Rep. SSC-086, 1986.
- [3] D. Lipka, “Heating of a DCCT and a FCT due to wake losses in PETRAIII, simulations and solutions”, presented at the Simulation of Power Dissipation & Heating from Wake Losses Workshop, Diamond Light Source, Oxfordshire, UK, Jan. 2013, unpublished.
- [4] C. Zannini, “Multi-physics simulations of impedance effects in accelerators”, presented at the ICFA Mini-Workshop on Impedances and Beam Instabilities in Particle Accelerators, Benevento, Italy, Sept. 2017, unpublished.
- [5] CST Studio Suite, <https://www.cst.com/products/csts2>
- [6] ANSYS, <https://www.ansys.com/>.
- [7] C. Zannini, “Electromagnetic Simulation of CERN accelerator Components and Experimental Applications”, Ph.D. thesis, Phys. Dept., Ecole Polytechnique, Lausanne, Switzerland, 2010.
- [8] B. Salvant, “Impedance model of the CERN SPS and aspects of LHC single-bunch stability”, Ph.D. thesis, Eng. Dept., Ecole Polytechnique, Lausanne, Switzerland, 2013.
- [9] A. Dallochio, “Study of Thermo-mechanical effects induced in Solids by High Energy Particle Beams: Analytical and Numerical Methods”, Ph.D. thesis, Phys. Dept., Politecnico di Torino, Torino, Italy, 2008.
- [10] C. Torregrosa, “Comprehensive Study for an Optimized Redesign of the CERN’s Antiproton Decelerator Target”, Ph.D. thesis, Eng. Dept., Universidad Politecnica de Valencia, Valencia, Spain, 2017.
- [11] G. Romagnoli *et al.*, “Design of the New PS Internal Dumps, in the Framework of the LHC Injector Upgrade (LIU) Project”, in *Proc. 8th Int. Particle Accelerator Conf. (IPAC'17)*, Copenhagen, Denmark, May 2017, paper WEPVA109, pp. 3521–3523.
- [12] I. Lamas *et al.*, “LHC Injection Protection Devices, Thermo-mechanical Studies through the Design Phase”, in *Proc. 7th Int. Particle Accelerator Conf. (IPAC'16)*, Busan, Korea, May 2016, paper THPMY019, pp. 3698–3701.
- [13] D. Carbajo Perez *et al.*, “Operational Feedback and Analysis of Current and Future Designs of the Injection Protection Absorbers in the Large Hadron Collider at CERN”, in *Proc. 8th Int. Particle Accelerator Conf. (IPAC'17)*, Copenhagen, Denmark, May 2017, paper WEPVA108, pp. 3517–3520.
- [14] C. Bracco, A. Iechner, D. Carbajo, A. Perillo, “TDIS - Functional Specification”. CERN, 2017, EDMS 1865250.
- [15] CST Studio Suite: Eigenmode Solver, <https://www.cst.com/products/cstmws/solvers/eigenmodesolver>
- [16] E. Jensen, “RF Cavity Design”, in *CAS - CERN Accelerator School: Advanced Accelerator Physics Course*, Trondheim, Norway, 18-29 Aug 2013, edited by W. Herr, CERN-2014-009, (CERN, Geneva, 2014), pp. 405–429.
- [17] J. Jackson, *Classical electrodynamics*, 3rd ed. edition, New York, NY, USA, Wiley, 1999.
- [18] CST Studio Suite: Thermal Solver, <https://www.cst.com/products/cstmps/solvers/solverthermal>
- [19] CST Studio Suite<sup>®</sup> online help, “Eigenmode Solver Overview”.
- [20] H. Wiedemann, “Impedances in an Accelerator Environment”, in *Particle Accelerator Physics*, Fourth edition, Springer, 2015, pp. 753.
- [21] CST Studio Suite: Wakefield Solver, <https://www.cst.com/products/cstps/solvers/wakefieldsolver>
- [22] L. Teofili, *et al.*, “Design of the new Proton Synchrotron Booster Absorber Scraper (PSBAS) in the framework of the Large Hadron Collider Injection Upgrade (LIU)”, presented at the 9th Int. Particle Accelerator Conf. (IPAC'18), Vancouver, Canada, May 2018, paper 2581, this conference.
- [23] L. Teofili, *et al.*, “Analysis on the Mechanical effects induced by beam impedance heating on the HL-LHC Target Dump Injection Segmented (TDIS) absorber”, presented at the 9th Int. Particle Accelerator Conf. (IPAC'18), Vancouver, Canada, May 2018, paper 2585, this conference.